

WDM[®]

PUMPS

GU Frame Mounted



GE Close Coupled



- Flow rates up to 4200 GPM
- Size up to 8" discharge
- Motors up to 200 HP
- Temperatures up to 158° F (70° C)

- Impeller in cast iron or stainless steel
- Cast iron case NPT up to 2", flanged from 2.5" up to 10" ANSI.

- Premium efficient motors-when provided with pump.
- Double volute design in select models
- Meets DOE pump standards



Technical Book

GS Line
End Suction Pumps

WDM PUMPS



www.wdmpumps.com

WDM Water Systems

WDM Pumps has expanded its brand as an international manufacturer of fluid handling pumps by consistently meeting and exceeding the needs of our customers.

Continuing a tradition of more than 60 years, WDM Pumps manufactures quality electric and engine driven pumps for diverse commercial and industrial applications. Our continued growth is based on a commitment to high standards for efficient product design, production, sales, and customer support.

Our customers rely on our world-class team of experienced WDM Pumps engineers, technicians, and product application specialists.

WDM offers pump products and related equipment for a wide variety of industries. WDM Pumps manufactured and distributed self priming, flexible coupled, close coupled, vertical multistage, submersible sump and sewage.

WDM Pumps plants are strategically located throughout the Americas.



INDEX



Pump Family		Content	Pag.
GS Line	GE - GU	Selection Charts	7-8
		Sectional GE Small Size	9
		Dimensions GE Small Size	10-11
		Sectional GE	12
		Dimensions GE 2 Poles (3600 rpm)	13-15
		Dimensions GE 4 Poles (1800 rpm)	16-19
		Sectional GU	20
		Dimensions GU	21-22
		Dimensions GU Frame Mounted with Motor	23-26
		Performance Curves	27-71

GS Line Close Coupled

Features:

- Material: Cast iron
- Suction: Up to 10"
- Discharge: Up to 8"
- Impeller: Enclosed, cast iron or stainless steel, dynamically balanced.
- Mechanical Seal: Standard ceramic/ carbon/ Buna-N.
- Wear Rings: Casting or bronze
- Motor: Three-phase up to 200 HP

Benefits:

- Quick delivery
- Easy set up & installation
- Low and easy maintenance
- Long service life
- Wide range of sizes



Nomenclature:

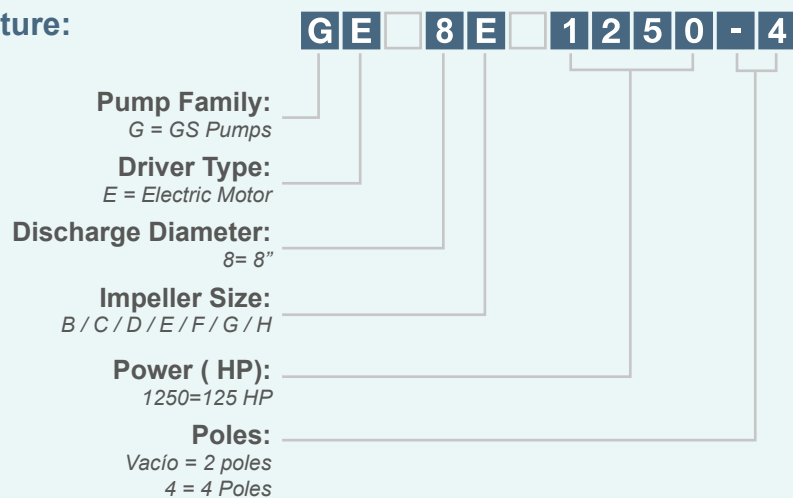

GS Line Frame Mounted

Features:

- Material: Cast Iron
- Suction: Up to 10"
- Discharge: Up to 8"
- Impeller: Enclosed, Stainless Steel or Cast Iron, Dynamically Balanced.
- Mechanical Seal: Standard Ceramic / Carbon / Buna-N.
- Wear Rings: Lead Free Bronze

Benefits:

- Quick Delivery
- Easy Set Up & Installation
- Low and Ease Maintenance
- Long Service Life
- Variety of Sizes



Nomenclature:

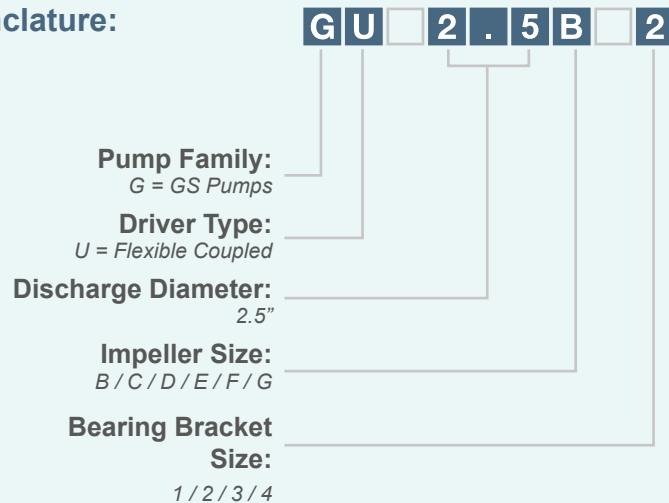

2 poles (3600 rpm) / 4 poles (1800 rpm)

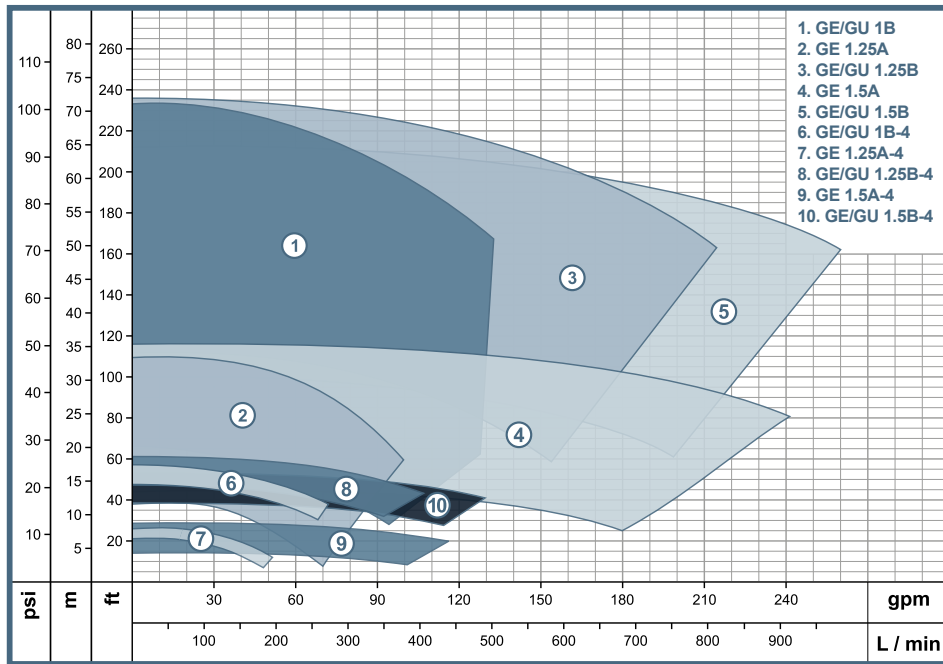

2 poles (3600 rpm)

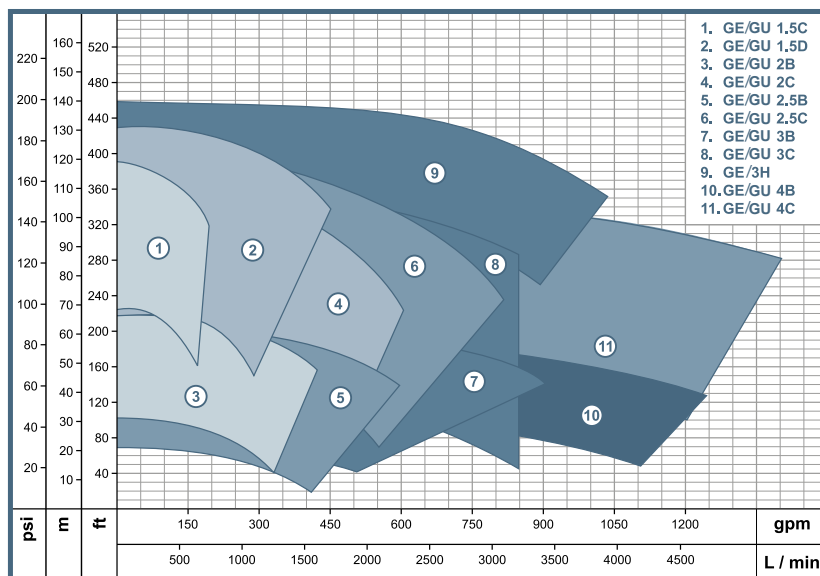

Selection Charts GE / GU Series

GS Line
Close Coupled Pumps



www.wdmpumps.com

4 poles (1800 rpm)

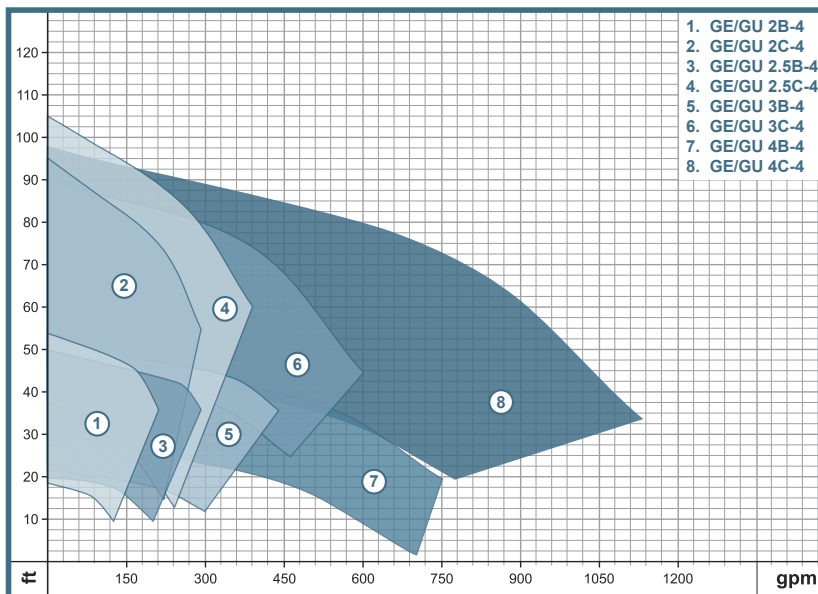

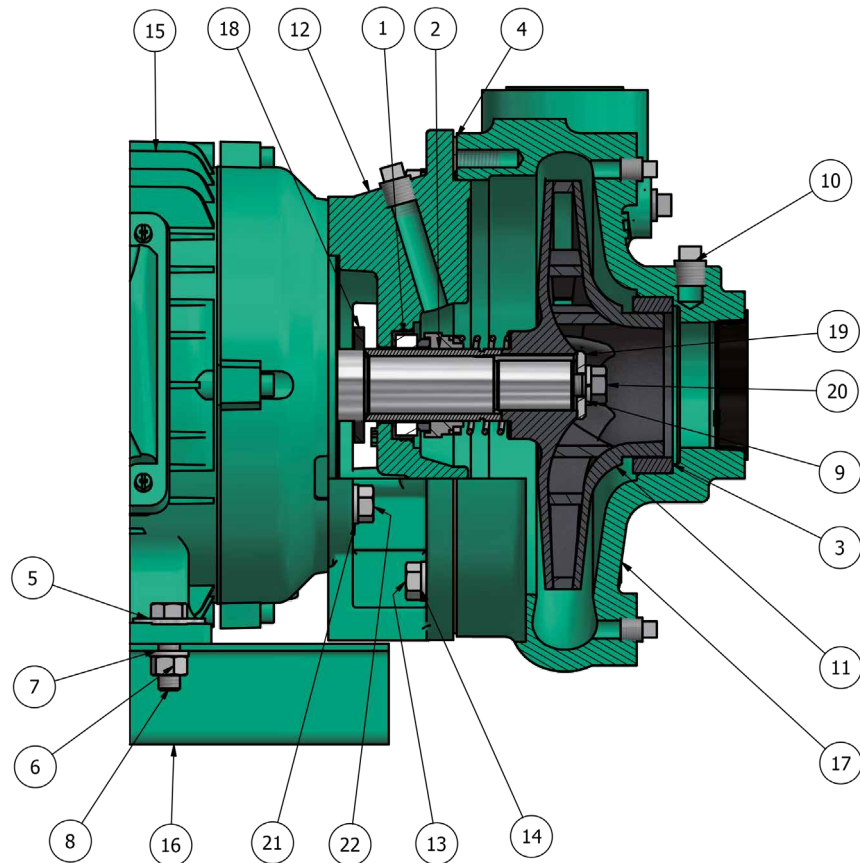

ITEM	QTY	DESCRIPTION	MATERIAL
1	1	MECHANICAL SEAL	CARBON / CERAMIC / BUNA
2	1	SHAFT SLEEVE	STAINLESS STEEL AISI 304
3	1	FRONT CASE WEAR RING*	CAST IRON ASTM A48
4	1	GASKET CASING	STANDARD PAPER GASKET
5	4	WASHER	CARBON STEEL
6	4	HEX NUT	CARBON STEEL
7	4	LOCK WASHER	CARBON STEEL
8	4	BOLT	CARBON STEEL
9	1	LOCK WASHER	STAINLESS STEEL AISI 304
10	1	PIPE PLUG	CARBON STEEL
11	1	IMPELLER	CAST IRON ASTM A48 / STAINLESS STEEL AISI 304

ITEM	QTY	DESCRIPTION	MATERIAL
12	1	BRACKET*	CAST IRON ASTM A48
13	6	BOLT	CARBON STEEL
14	6	LOCK WASHER	CARBON STEEL
15	1	MOTOR	CHECK INFO WITH SUPPLIER
16	1	BASE	CARBON STEEL
17	1	CASING	CAST IRON ASTM A48
18	1	SLINGER	BUNA
19	1	WASHER IMPELLER	STAINLESS STEEL AISI 304
20	1	BOLT	STAINLESS STEEL AISI 304
21	4	LOCK WASHER	CARBON STEEL
22	4	BOLT	CARBON STEEL

* This part could change depending of the reference, please contact our sales department in order to clarify any dudas.

Dimensions
GE Series
Small Size

GS Line
Close Coupled Pumps



www.wdmpumps.com

Drawing 1

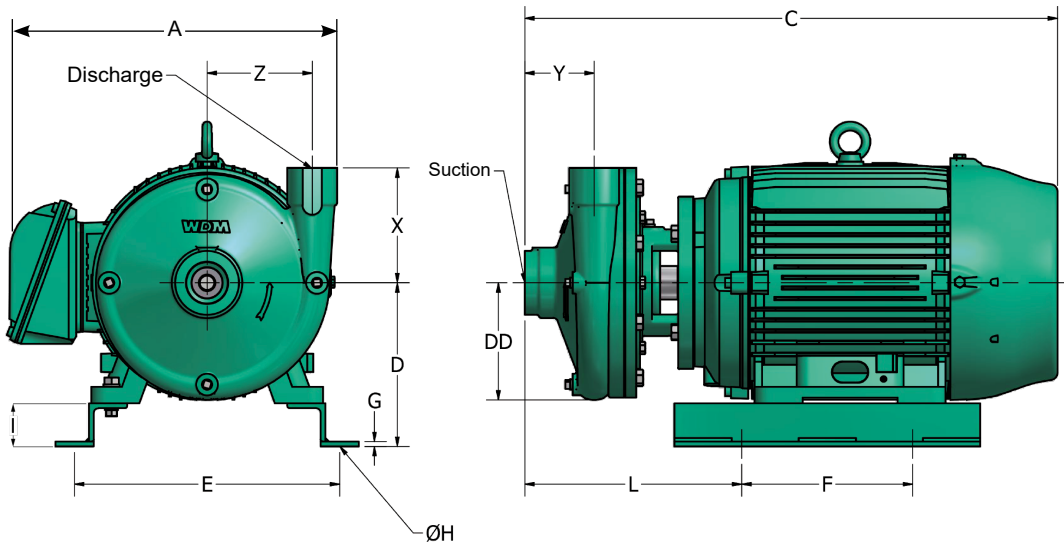

Drawing 2

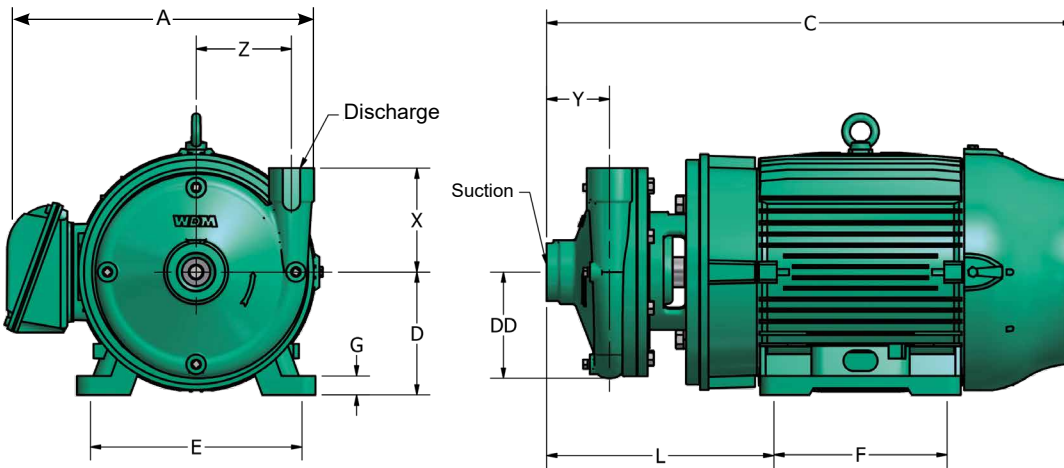

Motor dimensions may vary by motor manufacturer.

Technical specifications are subject to change without prior notice.

Dimensionals 3600 rpm - 2 poles (in)																			
MODEL	Ref. Cast Iron Imp.	Ref. Stainless Steel Imp.	Drawing	C	A	D	DD	E	F	G	H	I	L	X	Y	Z	Frame	Suc	Disc
GE 1B 20	1B0205	1B0205S	1	18 1/2	11 1/2	5	4 3/8	11 3/16	7 1/8	1/8	7/16	1 1/2"	7 9/16	4 1/2	3 1/4	4 1/16	145JM	1 1/4"	1"
GE 1B 30	1B0206	1B0206S	1	19 1/4	12 5/8	6	4 3/8	11 11/16	7 1/8	1/8	7/16	1 1/2"	7 1/4	4 1/2	3 1/4	4 1/16	145JM	1 1/4"	1"
GE 1B 50	1B0207	1B0207S	1	20 1/4	13 3/4	6 1/4	4 3/8	12 1/2	7	1/8	7/16	1 1/2"	8	4 1/2	3 1/4	4 1/16	182JM	1 1/4"	1"
GE 1B 75	1B0208	1B0208S	3	20 1/4	13 3/4	6 1/4	4 3/8	9 3/4	5 1/2	1	7/16	N/A	10 3/4	4 1/2	3 1/4	4 1/16	213JM	1 1/4"	1"
GE 1B 100	1B0209	1B0209S	3	21 7/8	13 3/4	5 1/4	4 3/8	9 11/16	7	1	7/16	N/A	10 3/4	4 1/2	3 1/4	4 1/16	215JM	1 1/4"	1"

GE 1.25A 7	1B0210	1B0210S	3	14 5/8	7 1/2	4 1/2	3 1/2	4 5/8	3 5/8	7/16	7/16	N/A	4 5/8	3 1/8	2 1/2	3 1/6	56J	1 1/2"	1 1/4"
GE 1.25A 10	1B0211	1B0211S	3	15 7/16	7 1/2	4 1/2	3 1/2	4 5/8	3 5/8	7/16	7/16	N/A	5 5/8	3 1/8	2 1/2	3 1/6	56J	1 1/2"	1 1/4"
GE 1.25A 15	1B0212	1B0212S	3	19 3/16	7 1/2	4 1/2	3 1/2	4 5/8	3 5/8	7/16	7/16	N/A	6 5/8	3 1/8	2 1/2	3 1/6	56J	1 1/2"	1 1/4"
GE 1.25A 20	1B0213	1B0213S	3	20 3/16	7 1/2	4 1/2	3 1/2	4 5/8	3 5/8	7/16	7/16	N/A	7 5/8	3 1/8	2 1/2	3 1/6	56J	1 1/2"	1 1/4"
GE 1.25A 30	1B0214	1B0214S	3	21 3/16	7 1/2	4 1/2	3 1/2	4 5/8	3 5/8	7/16	7/16	N/A	8 5/8	3 1/8	2 1/2	3 1/6	56J	1 1/2"	1 1/4"

GE 1.25B 50	1B0215	1B0215S	1	20 13/16	13 3/4	6 1/4	4 3/4	12.5	7	1/8	7/16	1 3/4"	8 9/16	4 1/2	3 5/16	4 5/16	182JM	1 1/2"	1 1/4"
GE 1.25B 75	1B0216	1B0216S	3	20 13/16	13 3/4	6 1/4	4 3/4	9 3/4	5 1/2	1	7/16	N/A	11 5/16	4 1/2	3 5/16	4 5/16	213JM	1 1/2"	1 1/4"
GE 1.25B 100	1B0217	1B0217S	3	22 7/16	14 3/16	5 1/4	4 3/4	9 3/4	7	1	7/16	N/A	11 1/4	4 1/2	3 5/16	4 5/16	215JM	1 1/2"	1 1/4"
GE 1.25B 150	1B0218	1B0218S	3	23 7/8	14 3/16	6 1/4	4 3/4	12 1/8	8 1/4	1	1/2	N/A	12 15/16	4 1/2	3 5/16	4 5/16	254JM	1 1/2"	1 1/4"

GE 1.5A 20	1B0450	1B0450S	1	18 1/2	11 1/4	5	3 3/4	11 3/16	7 1/8	1/8	7/16	1 1/2"	7 1/6	4	3 1/4	3 1/4	145JM	2"	1 1/2"
GE 1.5A 30	1B0451	1B0451S	1	19 1/4	12	6	3 3/4	11 5/8	7 1/8	1/8	7/16	1 1/2"	6 3/4	4	3 1/4	3 1/4	143JM	2"	1 1/2"
GE 1.5A 50	1B0452	1B0452S	1	19 3/4	12	6 1/4	3 3/4	11	7	1/8	7/16	1 1/2"	7 1/2	4	3 1/4	3 1/4	182JM	2"	1 1/2"
GE 1.5A 75	1B0453	1B0453S	3	19 3/4	12	6 1/4	3 3/4	8 1/2	5 1/2	1	7/16	N/A	10 1/8	4	3 1/4	3 1/4	184JM	2"	1 1/2"

GE 1.5B 50	1B0454	1B0454S	1	20 3/8	13 5/16	6 1/8	5	11	7	1/8	7/16	1 3/4"	8 1/8	5 1/8	3 1/8	4 3/8	182JM	2"	1 1/2"
GE 1.5B 75	1B0455P	1B0455PS	3	20 3/8	13 5/16	6 1/8	5	8 1/2	5 1/2	1	7/16	N/A	10 7/8	5 1/8	3 1/8	4 3/8	184 JM	2"	1 1/2"
GE 1.5B 100	1B0456	1B0456S	3	22	14 1/2	5 1/4	5	8 1/2	7	1	7/16	N/A	10 7/8	5 1/8	3 1/8	4 3/8	215JM	2"	1 1/2"
GE 1.5B 150	1B0457	1B0457S	3	23 1/2	14 1/2	6 1/4	5	10	8 1/4	1	1/2	N/A	12 1/2	5 1/8	3 1/8	4 3/8	215JM	2"	1 1/2"

Dimensionals 1800 rpm - 4 poles (in)																			
MODEL	Ref. Cast Iron Imp.	Ref. Stainless Steel Imp.	Drawing	C	A	D	DD	E	F	G	H	I	L	X	Y	Z	Frame	Suc	Disc
GE 1B 10-4	1B0460	1B0460S	1	18	11 1/4	6	4 5/16	9 11/16	7 1/8	1/8	3/8	1 1/2"	8 3/4	4 1/2	3 1/4	4 1/16	143JM	1 1/4"	1"
GE 1B 15-4	1B0461	1B0461S	1	18	12 5/8	6	4 5/16	9 11/16	7 1/8	1/8	3/8	1 1/2"	7 9/16	4 1/2	3 1/4	4 1/16	145JM	1 1/4"	1"

GE 1.25A 3-4	1B0462	1B0462S	2	19	10	4 1/2	3 1/2	4 5/8	3 5/8	7/16	7/16	N/A	4 11/16	3 1/2	2 1/2	3 1/8	56J	1 1/2"	1 1/4"
GE 1.25A 5-4	1B0463	1B0463S	2	19	10	4 1/2	3 1/2	4 5/8	3 5/8	7/16	7/16	N/A	4 11/16	3 1/2	2 1/2	3 1/8	56J	1 1/2"	1 1/4"

GE 1.25B 10-4	1B0464	1B0464S	1	19	13 3/4	6 1/8	4 3/4	9 11/16	7 1/8	1/8	3/8	1 3/4"	8 1/16	4 1/2	3 5/16	4 5/16	143JM	1 1/2"	1 1/4"
GE 1.25B 15-4	1B0465	1B0465S	1	19	14 3/16	5 1/4	4 3/4	9 11/16	7 1/8	1/8	3/8	1 3/4"	8 1/16	4 1/2	3 5/16	4 5/16	143JM	1 1/2"	1 1/4"
GE 1.25B 20-4	1B0466	1B0466S	1	19	14 3/16	5 1/4	4 3/4	9 11/16	7 1/8	1/8	3/8	1 3/4"	8 1/16	4 1/2	3 5/16	4 5/16	143JM	1 1/2"	1 1/4"

GE 1.5A 10-4	1B0467	1B0467S	1	17	11 1/4	3 11/16	4 3/4	9 11/16	7 1/8	1/8	3/8	1 1/2"	7 1/16	4	3 1/4	3 3/16	143JM	2"	1 1/2"
--------------	--------	---------	---	----	--------	---------	-------	---------	-------	-----	-----	--------	--------	---	-------	--------	-------	----	--------

GE 1.5B 10-4	1B0468	1B0468S	1	17 11/16	12	6 1/8	5	9 11/16	7 1/8	1/8	3/8	1 3/4"	7 11/16	5 1/8	3 1/8	4 3/8	143JM	2"	1 1/2"
GE 1.5B 15-4	1B0469	1B0469S	1	20 3/8	13 5/16	6 1/8	5	9 11/16	7 1/8	1/8	3/8	1 3/4"	7 11/16	5 1/8	3 1/8	4 3/8	145JM	2"	1 1/2"
GE 1.5B 20-4	1B0470	1B0470S	1	22	14 1/2	5 1/4	5	9 11/16	7 1/8	1/8	3/8	1 3/4"	7 11/16	5 1/8	3 1/8	4 3/8	145JM	2"	1 1/2"

Sectional GE Series

Sectional GE Series



www.wdmpumps.com

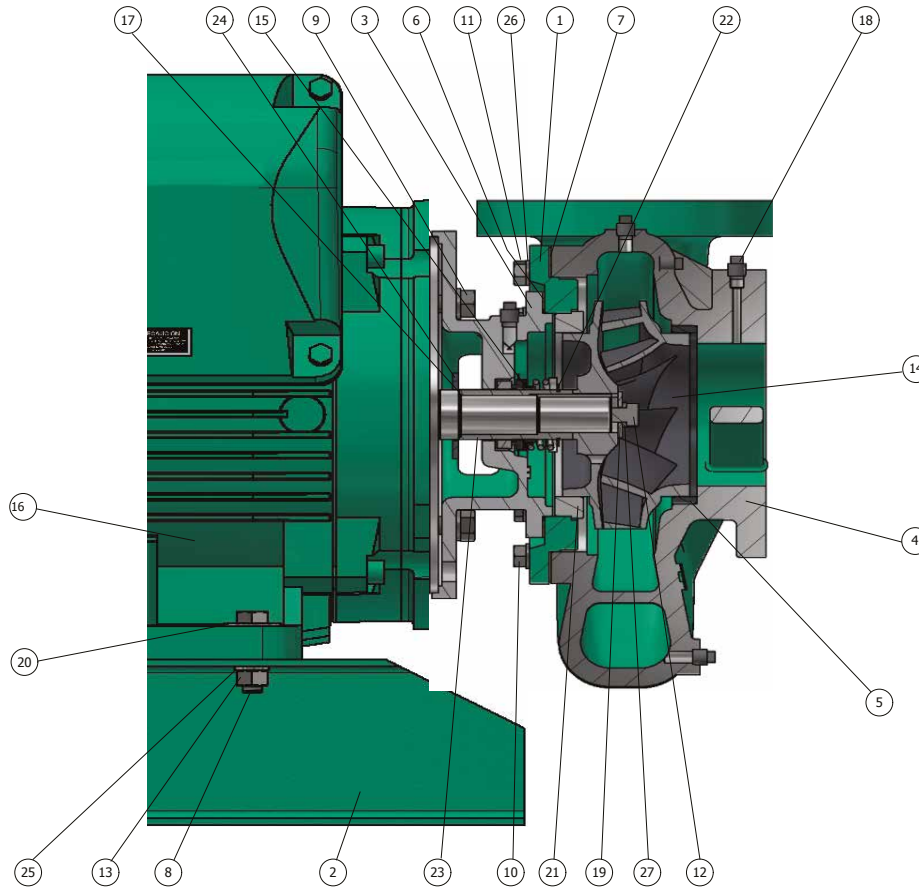

ITEM	QTY	DESCRIPTION	MATERIAL
1	1	BACKPLATE*	CAST IRON ASTM A48
2	2	BASE RAIL LEFT	CARBON STEEL
3	1	BRACKET*	CAST IRON ASTM A48
4	1	CASING	CAST IRON ASTM A48
5	1	FRONT CASE WEAR RING*	CAST IRON ASTM A48
6	1	GASKET	STANDARD PAPER GASKET
7	1	GASKET, CASING	STANDARD PAPER GASKET
8	4	BOLT	CARBON STEEL
9	4	BOLT	CARBON STEEL
10	6	BOLT	CARBON STEEL
11	8	BOLT	CARBON STEEL
12	1	BOLT	STAINLESS STEEL AISI 304
13	4	NUT	CARBON STEEL

ITEM	QTY	DESCRIPTION	MATERIAL
14	1	IMPELLER	STAINLESS STEEL AISI 304
15	1	MECHANICAL SEAL	CARBON / CERAMIC / BUNA
16	1	MOTOR	CHECK INFO WITH SUPPLIER
17	1	O-RING	BUNA
18	8	PIPE PLUG	CARBON STEEL
19	1	LOCK WASHER	STAINLESS STEEL AISI 304
20	4	PLAIN WASHER	CARBON STEEL
21	1	REAR WEAR RING*	CAST IRON ASTM A48
22	1	SEEGER RING	STAINLESS STEEL AISI 304
23	1	SHAFT SLEEVE	STAINLESS STEEL AISI 304
24	1	SLINGER	BUNA
25	4	LOCK WASHER	CARBON STEEL
26	8	LOCK WASHER	CARBON STEEL
27	1	LOCK WASHER	STAINLESS STEEL AISI 304

* This part could change depending of the reference, please contact our sales department in order to clarify any dudas.

Technical specifications are subject to change without prior notice.

Drawing 1

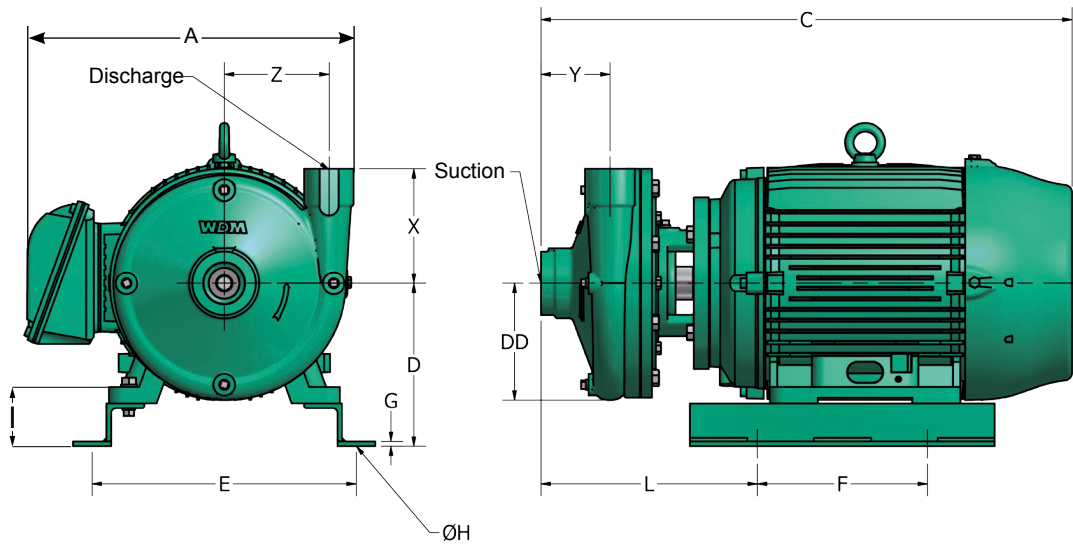

Drawing 2

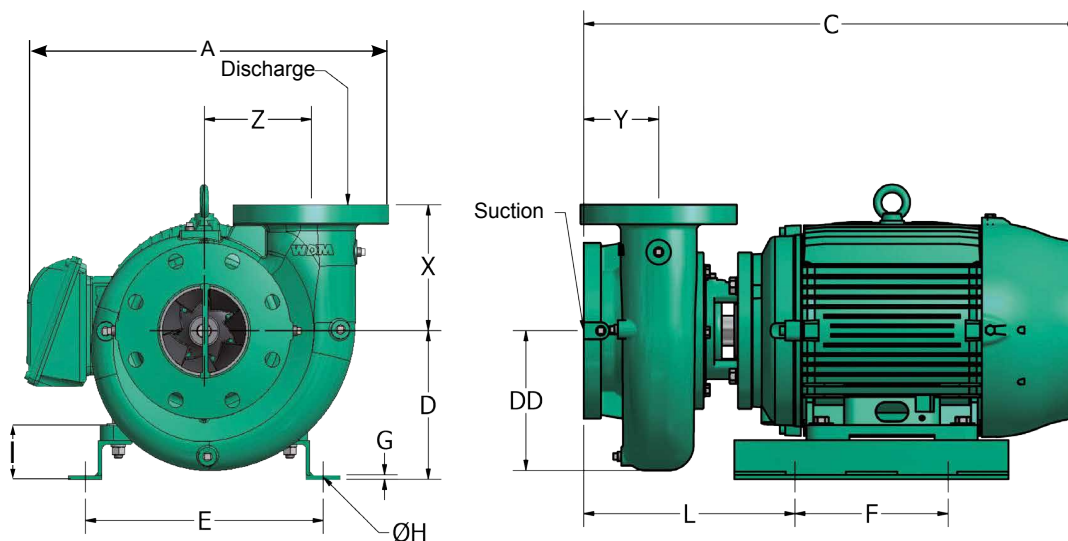

Drawing 3

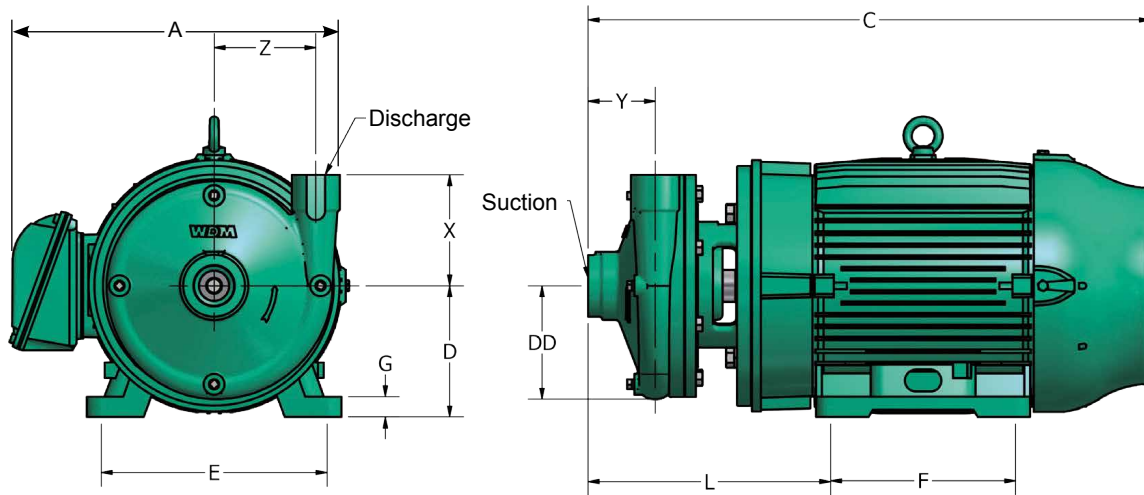

Drawing 4

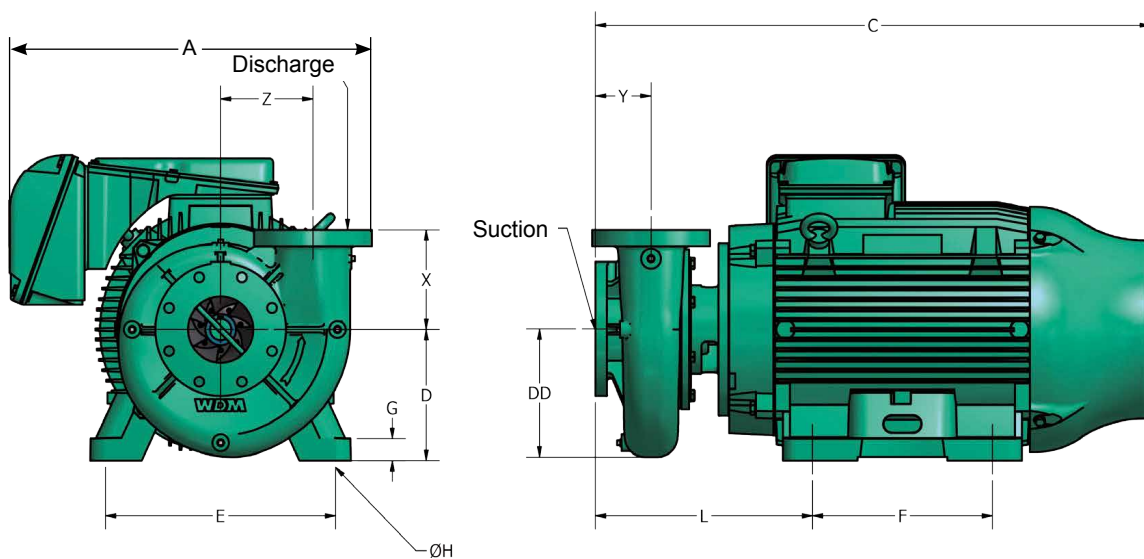

Dimensions (in)

MODEL	Ref. Cast Iron Imp.	Ref. Stainless Steel Imp.	Drawing	C	A	D	DD	E	F	G	H	I	L	X	Y	Z	Frame	Suc	Disc
GE 1.5C 100	1B0001	1B0001S	1	22 1/4	15 1/2	7	6 3/16"	12"	7"	1/8"	7/16"	1 3/4"	9 3/16"	3 5/8	3 5/8"	5 1/2"	215JM	2"	1,5"
GE 1.5C 150	1B0002	1B0002S	1	23 3/4	15 1/2	7	6 3/16"	13 7/8"	8 15/16"	1/4"	7/16"	1 3/4"	11 5/16"	3 5/8	3 5/8"	5 1/2"	215JM	2"	1,5"
GE 1.5C 200	1B0003	1B0003S	1	27 13/16	17 5/16	8 1/2	6 3/16"	13 7/8"	8 15/16"	1/4"	7/16"	2 1/4"	11 5/16"	3 5/8	3 5/8"	5 1/2"	254JM	2"	1,5"
GE 1.5C 250	1B0004	1B0004S	3	27 13/16	17 5/16	8 1/2	6 3/16"	11"	9 1/2"	1"	9/16"	N/A	13 3/8"	3 5/8	3 5/8"	5 1/2"	256JM	2"	1,5"
GE 1.5D 250	1B0006	1B0006S	3	27 7/8	17 1/4	8 1/2	6 3/16"	13 7/8"	8 15/16"	1/4"	7/16"	2 1/4"	11 5/16"	3 5/8	3 5/8"	5 1/2"	256JM	2"	1,5"
GE 1.5D 300	1B0007	1B0007S	3	30 3/8	14 1/2	7	6 3/16"	11"	9 1/2"	1"	9/16"	N/A	13 3/8"	3 5/8	3 5/8"	5 1/2"	286JM	2"	1,5"
GE 1.5D 400	1B0008	1B0008S	3	33	20 11/16	7 7/8	6 3/16"	11"	11"	1"	1/2"	N/A	13 7/8"	3 5/8	3 5/8"	5 1/2"	324JM	2"	1,5"
GE 1.5D 500	1B0009	1B0009S	3	38	24 7/8	8 1/2	6 3/16"	12 1/2"	10 1/2"	1 5/16"	11/16"	N/A	13 7/8"	3 5/8	3 5/8"	5 1/2"	326JM	2"	1,5"
GE 1.5D 600	1B0010	1B0010S	3	38	24 7/8	8 1/2	6 3/16"	12 1/2"	12"	1 5/16"	3/4"	N/A	14 7/16"	3 5/8	3 5/8"	5 1/2"	364JM	2"	1,5"

Motor dimensions may vary by motor manufacturer.

Technical specifications are subject to change without prior notice.

Dimensions (in)																			
Model	Ref. Cast Iron Imp.	Ref. Stainless Steel Imp.	Drawing	C	A	D	DD	E	F	G	H	I	L	X	Y	Z	Frame	Suc	Disc
GE 2B 75	1B0011	1B0011S	1	21	12 1/2	6 1/8	5 1/8"	12"	7"	1/8"	7/16"	1 3/4"	9 11/16"	5 3/8	4"	4 1/2"	184JM	2,5"	2"
GE 2B 100	1B0012	1B0012S	1	22 1/2	13 1/2	7	5 1/8"	12"	7"	1/8"	7/16"	1 3/4"	11 7/8"	5 3/8	4"	4 1/2"	215JM	2,5"	2"
GE 2B 150	1B0013	1B0013S	1	24	13 1/2	7	5 1/8"	13 7/8"	8 15/16"	1/4"	7/16"	1 3/4"	13 5/16"	5 3/8	4"	4 1/2"	215 JM	2,5"	2"
GE 2B 200	1B0014	1B0014S	1	28 1/8	13 5/16	6 5/16	5 1/8"	13 7/8"	8 15/16"	1/4"	7/16"	2 1/4"	13 5/16"	5 3/8	4"	4 1/2"	254JM	2,5"	2"
GE 2B 250	1B0015	1B0015S	3	28 1/8	13 5/16	6 5/16	5 1/8"	11"	9 1/2"	1"	9/16"	N/A	13 1/2"	5 3/8	4"	4 1/2"	256JM	2,5"	2"
GE 2C 200	1B0016	1B0016S	1	28 1/8	15 7/8	8 1/2	6 5/8"	13 7/8"	8 15/16"	1/4"	7/16"	2 1/4"	11 13/16"	6	3 3/4"	5 3/4"	254JM	2,5"	2"
GE 2C 250	1B0017	1B0017S	3	28 1/8	15 7/8	8 1/2	6 5/8"	11"	9 1/2"	1"	9/16"	N/A	10"	6	3 3/4"	5 3/4"	256JM	2,5"	2"
GE 2C 300	1B0018	1B0018S	3	30 3/4	13 3/4	7	6 5/8"	11"	11"	1"	1/2"	N/A	14 3/8"	6	3 3/4"	5 3/4"	286JM	2,5"	2"
GE 2C 400	1B0019	1B0019S	3	33 1/4	20 5/8	7 7/8	6 5/8"	12 1/2"	10 1/2"	1 5/16"	11/16"	N/A	14 3/8"	6	3 3/4"	5 3/4"	324JM	2,5"	2"
GE 2C 500	1B0020	1B0020S	3	34 7/8	20 5/8	7 7/8	6 5/8"	12 1/2"	12"	1 5/16"	3/4"	N/A	9 1/4"	6	3 3/4"	5 3/4"	326JM	2,5"	2"
GE 2C 600	1B0021	1B0021S	3	38 1/4	24 1/2	8 7/8	6 5/8"	14"	11 1/4"	1 1/2"	11/16"	N/A	14 1/2"	6	3 3/4"	5 3/4"	364 JM	2,5"	2"
GE 2.5B 75	1B0022	1B0022S	2	21 1/8	14	6 1/8	5 3/8"	12"	7"	1/8"	7/16"	1 3/4"	11 9/16"	5 5/8	3 5/8"	4 1/4"	184JM	3"	2,5"
GE 2.5B 100	1B0023	1B0023S	2	22 5/16	14 5/8	7	5 3/8"	12"	7"	1/8"	7/16"	1 3/4"	11 9/16"	5 5/8	3 5/8"	4 1/4"	215JM	3"	2,5"
GE 2.5B 150	1B0024	1B0024S	2	24	14 5/8	7	5 3/8"	13 7/8"	8 15/16"	1/4"	7/16"	1 3/4"	11 11/16"	5 5/8	3 5/8"	4 1/4"	215JM	3"	2,5"
GE 2.5B 200	1B0025	1B0025S	2	28 1/4	14 1/2	6 5/16	5 3/8"	13 7/8"	8 15/16"	1/4"	7/16"	N/A	11 11/16"	5 5/8	3 5/8"	4 1/4"	254JM	3"	2,5"
GE 2.5B 250	1B0026	1B0026S	4	28 1/4	15 3/4	8 1/2	5 3/8"	11"	9 1/2"	1"	9/16"	N/A	13 3/4"	5 5/8	3 5/8"	4 1/4"	256JM	3"	2,5"
GE 2.5B 300	1B0027	1B0027S	4	30 3/4	15 1/8	7	5 3/8"	11"	11"	1"	1/2"	N/A	13 3/4"	5 5/8	3 5/8"	4 1/4"	286JM	3"	2,5"
GE 2.5C 200	1B0028	1B0028S	2	29	17 5/8	8 1/2	6 3/4"	13 7/8"	8 15/16"	1/4"	7/16"	2 1/4"	12 3/4"	6 3/4	4 1/8"	6"	254JM	3"	2,5"
GE 2.5C 250	1B0029	1B0029S	2	29	17 5/8	8 1/2	6 3/4"	11 1/4"	16"	1/4"	9/16"	2 1/4"	10 7/8"	6 3/4	4 1/8"	6"	256JM	3"	2,5"
GE 2.5C 300	1B0029	1B0029S	2	31 5/8	17	7	6 3/4"	11"	11"	1"	1/2"	N/A	12"	6 3/4	4 1/8"	6"	286JM	3"	2,5"
GE 2.5C 400	1B0031	1B0031S	4	34 1/8	22 1/4	7 7/8	6 3/4"	12 1/2"	10 1/2"	1 5/16"	11/16"	N/A	12"	6 3/4	4 1/8"	6"	324JM	3"	2,5"
GE 2.5C 500	1B0032	1B0032S	4	35 5/8	17 7/8	7 7/8	6 3/4"	12 1/2"	12"	1 5/16"	3/4"	N/A	15 7/16"	6 3/4	4 1/8"	6"	326JM	3"	2,5"
GE 2.5C 600	1B0033	1B0033S	4	39 1/4	25 1/2	8 7/8	6 3/4"	14"	11 1/4"	1 1/2"	11/16"	N/A	15 7/8"	6 3/4	4 1/8"	6"	364JM	3"	2,5"
GE 2.5C 750	1B0034	1B0034S	4	39 1/4	25 1/2	8 7/8	6 3/4"	14"	12 1/4"	1 1/2"	11/16"	N/A	16 13/16"	6 3/4	4 1/8"	6"	365JM	3"	2,5"
GE 3B 100	1B0035	1B0035S	2	23 1/8	15 3/8	7	6 1/4"	12"	7"	1/8"	7/16"	1 3/4"	18 1/2"	6	4 1/8"	5"	215JM	4"	3"
GE 3B 150	1B0036	1B0036S	2	24 5/8	15 3/8	7	6 1/4"	13 7/8"	8 15/16"	1/4"	7/16"	1 3/4"	12 1/4"	6	4 1/8"	5"	215JM	4"	3"
GE 3B 200	1B0037	1B0037S	2	28 3/4	16 1/2	8 1/2	6 1/4"	13 7/8"	8 15/16"	1/4"	7/16"	2 1/4"	12 1/4"	6	4 1/8"	5"	254JM	4"	3"
GE 3B 250	1B0038	1B0038S	2	28 3/4	16 1/2	8 1/2	6 1/4"	11 1/4"	16"	1/4"	9/16"	2 1/4"	10 1/8"	6	4 1/8"	5"	256JM	4"	3"
GE 3B 300	1B0039	1B0039S	4	31 3/8	10	15 1/2	6 1/4"	11"	11"	1"	1/2"	N/A	14 13/16"	6	4 1/8"	5"	286JM	4"	3"
GE 3B 400	1B0040	1B0040S	4	33 7/8	21 1/8	7 7/8	6 1/4"	12 1/2"	10 1/2"	1 5/16"	11/16"	N/A	14 13/16"	6	4 1/8"	5"	324JM	4"	3"
GE 3C 250	1B0041	1B0041S	2	28 5/16	18	8 1/2	8"	11 1/4"	16"	1/4"	9/16"	2 1/4"	12 3/8"	7	4"	6 1/4"	256JM	4"	3"
GE 3C 300	1B0042	1B0042S	2	30 7/8	17 1/2	10	8"	12 1/2"	11 7/16"	1 5/16"	9/16"	3"	12 3/16"	7	4"	6 1/4"	286JM	4"	3"
GE 3C 400	1B0043	1B0043S	2	33 1/8	22 1/2	10	8"	12 1/2"	14 1/2"	5/16"	9/16"	4"	10 3/16"	7	4"	6 1/4"	324JM	4"	3"
GE 3C 500	1B0044	1B0044S	2	35	22 1/2	12	8"	12 1/2"	14 1/2"	5/16"	9/16"	4"	14 5/8"	7	4"	6 1/4"	326 JM	4"	3"
GE 3C 600	1B0045	1B0045S	4	38 5/8	26	8 7/8	8"	14"	11 1/4"	1 1/2"	11/16"	N/A	15 3/16"	7	4"	6 1/4"	364JM	4"	3"
GE 3C 750	1B0046	1B0046S	4	38 5/8	26	8 7/8	8"	14"	12 1/4"	1 1/2"	11/16"	N/A	15 1/16"	7	4"	6 1/4"	365JM	4"	3"
GE 3H 750	1B0144	1B0144S	4	39 3/8	26 1/8	8 3/4	7 15/16"	14"	12 1/4"	1 1/2"	11/16"	N/A	18 7/16"	11	4 7/8"	6 1/2"	365JM	5"	3"
GE 3H 1000	1B0145	1B0145S	4	36 5/8	25 7/8	9	7 15/16"	16"	13 3/4"	1 13/16"	13/16"	N/A	18 7/16"	11	4 7/8"	6 1/2"	364JP	5"	3"
GE 3H 1250	1B0146	1B0146S	2	49 1/8	29 1/5	11 1/8	7 57/64"	15-63/64"	12 1/4"	1 21/32"	15/16"	N/A	19 3/16"	11	4 7/8"	6 7/16"	444JP	5"	3"
GE 4B 250	1B0047	1B0047S	2	28 7/8	18 1/8	8 1/2	8"	11 1/4"	16"	1/4"	9/16"	2 1/4"	10 11/16"	8 5/8	4 3/8"	6 1/4"	256JM	5"	4"
GE 4B 300	1B0048	1B0048S	2	31 3/8	18 1/8	10	8"	12 1/2"	11 7/16"	1 5/16"	9/16"	3"	12 1/2"	8 5/8	4 3/8"	6 1/4"	286JM	5"	4"
GE 4B 400	1B0049	1B0049S	4	34	23 3/8	23 3/8	8"	12 1/2"	11 7/16"	1 5/16"	9/16"	6"	12 1/2"	8 5/8	4 3/8"	6 1/4"	324JM	5"	4"
GE 4B 500	1B0050	1B0050S	4	35 1/4	19	7 1/4	8"	12 1/2"	12"	1 5/16"	3/4"	N/A	14 7/8"	8 5/8	4 3/8"	6 1/4"	326JM	5"	4"
GE 4C 500	1B0051	1B0051S	4	35 3/4	24	13 7/8	9 1/2"	12 1/2"	12"	1 5/16"	3/4"	N/A	18 1/2"	7 1/2	4 1/4"	6 7/8"	326JM	5"	4"
GE 4C 600	1B0137	1B0137S	4	39 3/8	27 1/2	14 7/8	9 1/2"	14"	11 1/4"	1 1/2"	11/16"	N/A	13 3/16"	7 1/2	4 1/4"	6 7/8"	364JM	5"	4"
GE 4C 750	1B0052	1B0052S	4	41 7/8	27 1/2	14 7/8	9 1/2"	14"	12 1/4"	1 1/2"	11/16"	N/A	18 1/2"	7 1/2	4 1/4"	6 7/8"	365JM	5"	4"
GE 4C 1000	1B0053	1B0053S	4	36 1/2	27 1/8	13	9 1/2"	16"	13 3/4"	1 13/16"	13/16"	N/A	19 1/4"	7 1/2	4 1/4"	6 7/8"	364JP	5"	4"
GE 4C 1250	1B0054	1B0054S	4	49	29 5/16	11	9 1/2"	16"	13 3/4"	1 13/16"	13/16"	N/A	19 1/16"	7 1/2	4 1/4"	6 7/8"	444JP	5"	4"

Motor dimensions may vary by motor manufacturer.

Technical specifications are subject to change without prior notice.

**Dimensions
GE Series**
4 poles (1800 rpm)
**GS Line
Close Coupled Pumps**



www.wdmpumps.com

Drawing 1

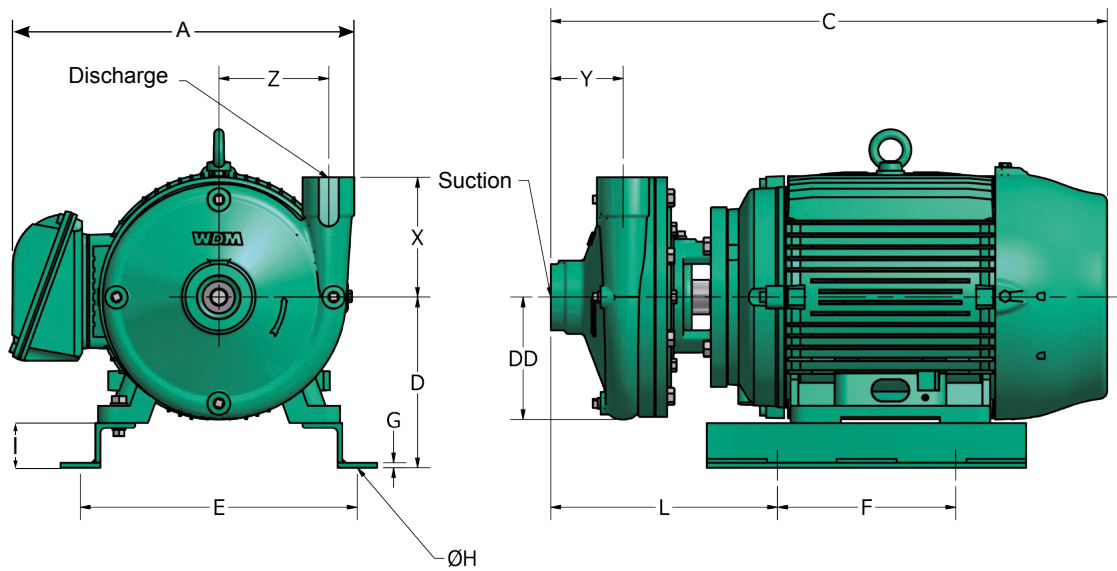

Drawing 2

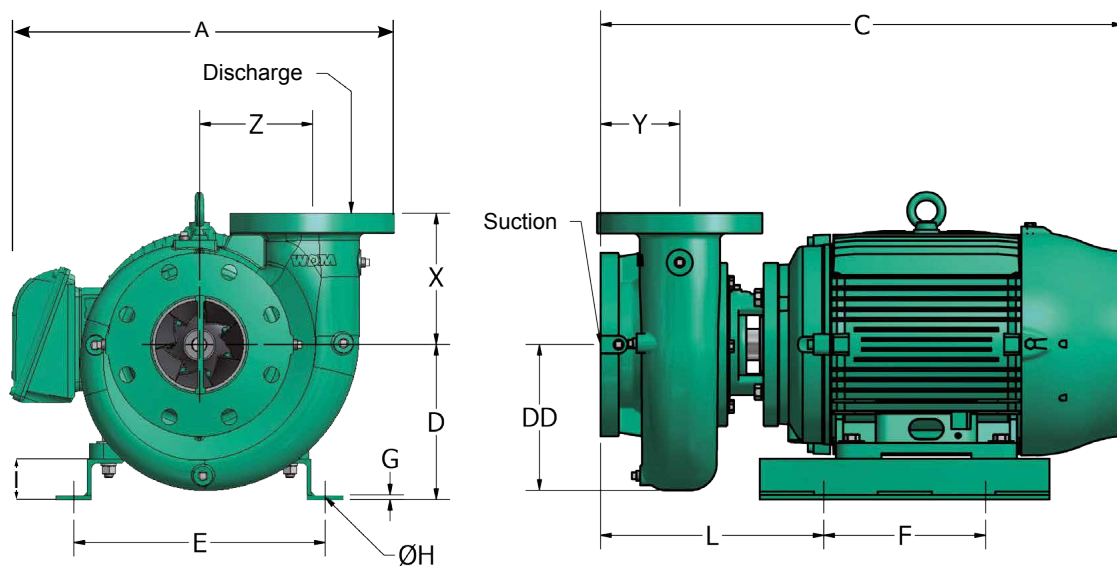

Drawing 3

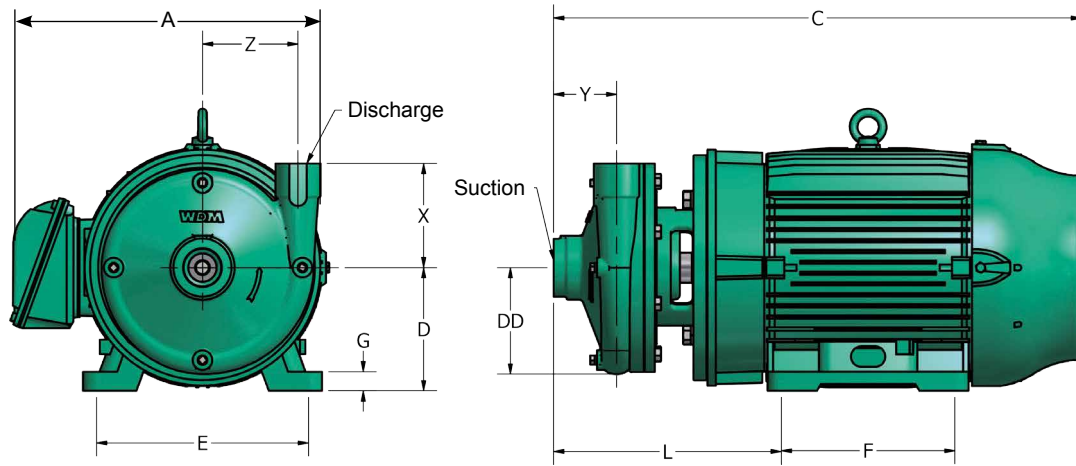

Drawing 4

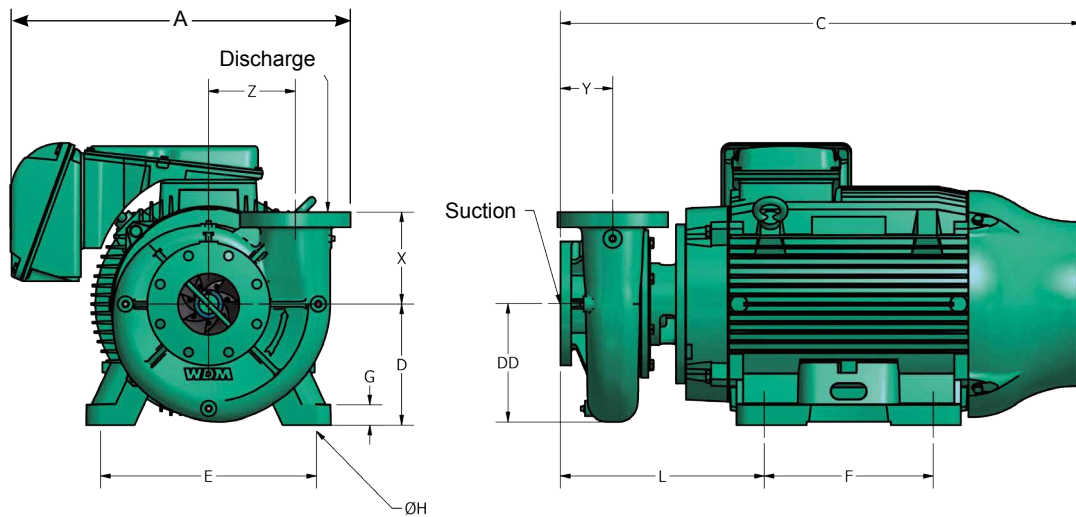

Dimensions (in)

MODEL	Ref. Cast Iron Imp.	Ref. Stainless Steel Imp.	Drawing	C	A	D	DD	E	F	G	H	I	L	X	Y	Z	Frame	Suc	Disc
GE 1.5C 15-4	1B0237	1B0237S	1	19	13	6 1/2	6 3/16"	5 1/2"	6"	5/16"	7/16"	3"	7 7/8"	6"	3 5/8"	5 1/2"	145JM	2"	1,5"
GE 1.5C 20-4	1B0238	1B0238S	1	19	13	6 1/2	6 3/16"	5 1/2"	6"	5/16"	7/16"	3"	7 7/8"	6"	3 5/8"	5 1/2"	145JM	2"	1,5"
GE 1.5C 30-4	1B0239	1B0239S	1	20 5/8	14 1/3	6 1/8	6 3/16"	11"	7"	1/8"	7/16"	3"	8 1/2"	6"	3 5/8"	5 1/2"	182JM	2"	1,5"
GE 1.5C 50-4	1B0240	1B0240S	1	20 5/8	13 7/16	7 7/16	6 3/16"	11"	7"	1/8"	7/16"	1 3/4"	8 1/2"	6"	3 5/8"	5 1/2"	184JM	2"	1,5"
GE 1.5D 20-4	1B0201	1B0201S	1	19	12 7/8	5 5/6	6 3/16"	5 1/2"	6"	5/16"	7/16"	3"	7 7/8"	6"	3 5/8"	5 1/2"	145JM	2"	1,5"
GE 1.5D 30-4	1B0202	1B0202S	1	20 5/8	14 3/8	7 7/16	6 3/16"	11"	7"	1/8"	7/16"	3"	8 1/2"	6"	3 5/8"	5 1/2"	182JM	2"	1,5"
GE 1.5D 50-4	1B0203	1B0203S	1	22 1/4	12 7/8	8 1/4	6 3/16"	11"	7"	1/8"	7/16"	3"	8 1/2"	6"	3 5/8"	5 1/2"	184JM	2"	1,5"
GE 1.5D 75-4	1B0204	1B0204S	1	22 1/8	12 7/8	8 1/2	6 3/16"	12"	7"	1/8"	7/16"	3"	9 1/4"	6"	3 5/8"	5 1/2"	213JM	2"	1,5"
GE 2B 7-4	1B0220	1B0220S	1	17 1/4	11	6 1/8	5 1/8"	5 1/2"	6"	5/16"	7/16"	3"	8 5/16"	5 5/16	4"	4 1/2"	56J	2,5"	2"
GE 2B 10-4	1B0221	1B0221S	1	18 7/16	11	6 1/2	5 1/8"	5 1/2"	6"	5/16"	7/16"	3"	8 5/16"	5 5/16	4"	4 1/2"	143JM	2,5"	2"
GE 2B 15-4	1B0222	1B0222S	1	19 1/4	18 7/8	6 1/2	5 1/8"	5 1/2"	6"	5/16"	7/16"	3"	9 1/4"	5 5/16	4"	4 1/2"	145JM	2,5"	2"
GE 2B 20-4	1B0223	1B0223S	1	19 1/4	11	6 1/2	5 1/8"	5 1/2"	6"	5/16"	7/16"	3"	9 1/4"	5 5/16	4"	4 1/2"	145JM	2,5"	2"
GE 2B 30-4	1B0224	1B0224S	1	21	13 5/8	6 1/8	5 1/8"	11"	7"	1/8"	7/16"	1 3/4"	8 11/16"	5 5/16	4"	4 1/2"	182JM	2,5"	2"

Motor dimensions may vary by motor manufacturer.

Technical specifications are subject to change without prior notice.

Dimensions (in)																			
MODEL	Ref. Cast Iron Imp.	Ref. Stainless Steel Imp.	Drawing	C	A	D	DD	E	F	G	H	I	L	X	Y	Z	Frame	Suc	Disc
GE 2C 20-4	1B0241	1B0241S	1	19 3/16	13 7/16	6 1/2	6 5/8"	5 1/2"	6"	5/16"	7/16"	3"	8 3/8"	6	3 3/4"	5 3/4"	145JM	2.5"	2"
GE 2C 30-4	1B0242	1B0242S	1	21	15	7 7/16	6 5/8"	7 1/2"	6"	5/16"	7/16"	3"	9 13/16"	6	3 3/4"	5 3/4"	182JM	2.5"	2"
GE 2C 50-4	1B0243	1B0243S	1	21	14	7 7/16	6 5/8"	7 1/2"	6"	5/16"	7/16"	3"	10 1/16"	6	3 3/4"	5 3/4"	184JM	2.5"	2"
GE 2C 75-4	1B0244	1B0244S	1	22 7/16	13 7/16	7	6 5/8"	12"	7"	1/8"	7/16"	1 3/4"	9 11/16"	6	3 3/4"	5 3/4"	213JM	2.5"	2"
GE 2E 50-4	1B0065	1B0065S	1	21 7/8	15 7/8	8 7/16	7 1/2"	7 1/2"	8 5/16"	5/16"	7/16"	4"	9 3/8"	8	4"	6 3/4"	184JM	2.5"	2"
GE 2E 75-4	1B0066	1B0066S	1	23 5/16	15 3/4	8	7 1/2"	8 1/2"	8 5/16"	1/4"	7/16"	2 3/4"	10 1/16"	8	4"	6 3/4"	213JM	2.5"	2"
GE 2E 100-4	1B0067	1B0067S	1	25	15 3/4	9 3/16	7 1/2"	8 1/2"	8 5/16"	1/4"	7/16"	4"	10 1/16"	8	4"	6 3/4"	215JM	2.5"	2"
GE 2E 150-4	1B0068	1B0068S	1	24 3/4	15 3/4	9 3/16	7 1/2"	13 7/8"	8 15/16"	1/4"	7/16"	4"	12 1/2"	8	4"	6 3/4"	215 JM	2.5"	2"
GE 2.5B 10-4	1B0225	1B0225S	2	18 5/16	14	6 1/2	5 3/8"	5 1/2"	6"	5/16"	7/16"	3"	8 1/4"	5 5/8	3 5/8"	4 1/2"	143JM	3"	2.5"
GE 2.5B 15-4	1B0226	1B0226S	2	19 5/16	14	6 1/2	5 3/8"	5 1/2"	6"	5/16"	7/16"	3"	9 1/4"	5 5/8	3 5/8"	4 1/2"	145JM	3"	2.5"
GE 2.5B 20-4	1B0227	1B0227S	2	19 5/16	13	6 1/2	5 3/8"	5 1/2"	6"	5/16"	7/16"	3"	9 1/4"	5 5/8	3 5/8"	4 1/2"	145JM	3"	2.5"
GE 2.5B 30-4	1B0228	1B0228S	2	21	15 7/16	7 7/16	5 3/8"	7 1/2"	6"	5/16"	7/16"	3"	9 3/8"	5 5/8	3 5/8"	4 1/2"	182JM	3"	2.5"
GE 2.5C 20-4	1B0245	1B0245S	2	20 1/8	16 1/8	7 1/2	6 3/4"	5 1/2"	6"	5/16"	7/16"	3"	10 5/16"	6 3/4	4 1/8"	6"	145JM	3"	2.5"
GE 2.5C 30-4	1B0246	1B0246S	2	21 7/8	17 1/4	7 7/16	6 3/4"	7 1/2"	6"	5/16"	7/16"	3"	11"	6 3/4	4 1/8"	6"	182JM	3"	2.5"
GE 2.5C 50-4	1B0247	1B0247S	2	21 7/8	16 5/16	7 7/16	6 3/4"	7 1/2"	6"	5/16"	7/16"	3"	11"	6 3/4	4 1/8"	6"	184JM	3"	2.5"
GE 2.5C 75-4	1B0248	1B0248S	2	23 3/8	26 3/16	9 3/16	6 3/4"	8 1/2"	6"	5/16"	7/16"	3"	11 3/4"	6 3/4	4 1/8"	6"	213JM	3"	2.5"
GE 2.5E 75-4	1B0069	1B0069S	2	23	18	8	7 5/8"	12"	7 1/8"	1/4"	7/16"	2 3/4"	10 3/4"	8 3/8	3 3/4"	7"	213JM	3"	2.5"
GE 2.5E 100-4	1B0070	1B0070S	2	24 7/16	18	9 3/16	7 5/8"	8 1/2"	8 5/16"	1/4"	7/16"	4"	9 5/8"	8 3/8	3 3/4"	7"	215 JM	3"	2.5"
GE 2.5E 150-4	1B0071	1B0071S	2	24 7/16	18	9 3/16	7 5/8"	13 7/8"	8 15/16"	1/4"	7/16"	4"	12 1/8"	8 3/8	3 3/4"	7"	215JM	3"	2.5"
GE 2.5E 200-4	1B0072	1B0072S	2	30 1/4	18	8 1/2	7 5/8"	13 7/8"	8 15/16"	1/4"	7/16"	2 1/4"	13 13/16"	8 3/8	3 3/4"	7"	256JM	3"	2.5"
GE 3B 15-4	1B0230	1B0230S	2	19 7/8	14 7/8	6 1/2	5 7/8"	5 1/2"	6"	5/16"	7/16"	3"	9 13/16"	6	4 1/8"	5"	145JM	4"	3"
GE 3B 20-4	1B0231	1B0231S	2	19 7/8	14 7/8	6 1/2	5 7/8"	5 1/2"	6"	5/16"	7/16"	3"	9 7/8"	6	4 1/8"	5"	145JM	4"	3"
GE 3B 30-4	1B0232	1B0232S	2	21 5/8	16 1/8	7 7/16	5 7/8"	7 1/2"	6"	5/16"	7/16"	3"	10 9/16"	6	4 1/8"	5"	182JM	4"	3"
GE 3B 50-4	1B0233	1B0233S	2	21 5/8	15 1/4	6 1/8	5 7/8"	11"	7"	1/8"	7/16"	1 3/4"	11 11/16"	6	4 1/8"	5"	184JM	4"	3"
GE 3C 30-4	1B0249	1B0249S	2	21 3/8	17 1/2	8 3/8	8"	7 1/2"	8 5/16"	1/4"	7/16"	4"	8 13/16"	7	4"	6 1/4"	182JM	4"	3"
GE 3C 50-4	1B0250	1B0250S	2	21 3/8	17 1/2	8 3/8	8"	7 1/2"	8 5/16"	1/4"	7/16"	4"	8 13/16"	7	4"	6 1/4"	184JM	4"	3"
GE 3C 75-4	1B0251	1B0251S	2	23	17 7/16	9 1/2	8"	8 1/2"	8 5/16"	1/4"	7/16"	4"	9 1/2"	7	4"	6 1/4"	213JM	4"	3"
GE 3C 100-4	1B0252	1B0252S	2	24 7/16	14 7/16	9 1/8	8"	8 1/2"	8 5/16"	1/4"	7/16"	4"	9 11/16"	7	4"	6 1/4"	215JM	4"	3"
GE 3E 100-4	1B0073	1B0073S	2	24 7/8	19	9 1/8	8 3/8"	8 1/2"	8 5/16"	1/4"	7/16"	4"	10 1/16"	8 5/8	3 7/8"	7 1/4"	215JM	4"	3"
GE 3E 150-4	1B0074	1B0074S	2	24 5/8	19	9 1/8	8 3/8"	13 7/8"	8 15/16"	1/4"	7/16"	4"	12 7/16"	8 5/8	3 7/8"	7 1/4"	215JM	4"	3"
GE 3E 200-4	1B0075	1B0075S	2	30 5/8	19	10 5/16	8 3/8"	9 3/4"	11 13/16"	1/4"	9/16"	4"	12 9/16"	8 5/8	3 7/8"	7 1/4"	256JM	4"	3"
GE 3E 250-4	1B0076	1B0076S	2	31 7/16	19	11	8 3/8"	10 3/4"	11 13/16"	1/4"	9/16"	4"	13 1/16"	8 5/8	3 7/8"	7 1/4"	284JM	4"	3"
GE 3F 150-4	1B0077	1B0077S	2	24 7/8	19	9 3/16	8 3/8"	13 7/8"	8 15/16"	1/4"	7/16"	4"	12 7/16"	8 5/8	3 7/8"	7 1/4"	215JM	4"	3"
GE 3F 200-4	1B0078	1B0078S	2	30 3/4	19	10 1/4	8 3/8"	9 3/4"	11 13/16"	1/4"	9/16"	4"	12 9/16"	8 5/8	3 7/8"	7 1/4"	256JM	4"	3"
GE 3F 250-4	1B0079	1B0079S	2	31 1/2	21 7/8	11	8 3/8"	10 3/4"	11 13/16"	1/4"	9/16"	4"	13 1/16"	8 5/8	3 7/8"	7 1/4"	284JM	4"	3"
GE 3F 300-4	1B0080	1B0080S	2	31 1/2	19	11	8 3/8"	11"	14 1/2"	5/16"	9/16"	4"	10 11/16"	8 5/8	3 7/8"	7 1/4"	286JM	4"	3"
GE 3G 250-4	1B0156	1B0156S	2	32 1/8	21 3/4	11	10"	10 3/4"	11 13/16"	1/4"	9/16"	4"	14 3/16"	9 3/4	3 3/4"	8"	284JM	4"	3"
GE 3G 300-4	1B0157	1B0157S	2	32 1/8	21 3/4	11	10"	11"	14 1/2"	5/16"	9/16"	4"	11 5/16"	9 3/4	3 3/4"	8"	286JM	4"	3"
GE 3G 400-4	1B0158	1B0158S	2	36 1/8	21 3/4	11 7/8	10"	12 1/2"	14 1/2"	5/16"	9/16"	4"	12 1/2"	9 3/4	3 3/4"	8"	326JM	4"	3"
GE 3G 500-4	1B0159	1B0159S	2	36 1/8	24 3/8	11 7/8	10"	12 1/2"	14 1/2"	5/16"	9/16"	4"	12 13/16"	9 3/4	3 3/4"	8"	326JM	4"	3"
GE 4B 30-4	1B0234	1B0234S	2	21 9/16	18 3/8	8 7/16	8"	7 1/2"	6"	5/16"	7/16"	3"	10 5/8"	7 1/4	4 3/8"	6 1/4"	182JM	5"	4"
GE 4B 50-4	1B0235	1B0235S	2	21 9/16	17 3/8	8 7/16	8"	7 1/2"	6"	5/16"	7/16"	3"	10 5/8"	7 1/4	4 3/8"	6 1/4"	184JM	5"	4"
GE 4B 75-4	1B0236	1B0236S	2	23	17 3/8	8 3/16	8"	8 1/2"	6"	5/16"	7/16"	3"	11 3/8"	7 1/4	4 3/8"	6 1/4"	213JM	5"	4"
GE 4C 75-4	1B0263	1B0263S	2	24 7/8	19 1/2	11 3/16	9 1/2"	8 1/2"	8 5/16"	1/4"	7/16"	4"	10 7/16"	7 1/2	4 1/4"	6 7/8"	213JM	5"	4"
GE 4C 100-4	1B0264	1B0264S	2	25	19 1/2	11 3/16	9 1/2"	8 1/2"	8 5/16"	1/4"	7/16"	4"	10 5/16"	7 1/2	4 1/4"	6 7/8"	215JM	5"	4"

Motor dimensions may vary by motor manufacturer.

Technical specifications are subject to change without prior notice.

Dimensions (in)																			
MODEL	Ref. Cast Iron Imp.	Ref. Stainless Steel Imp.	Drawing	C	A	D	DD	E	F	G	H	I	L	X	Y	Z	Frame	Suc	Disc
GE 4C 150-4	1B0265	1B0265S	2	29	19 1/2	10 1/3	9 1/2"	9 3/4"	11 13/16"	1/4"	9/16"	4"	12 3/16"	7 1/2	4 1/4"	6 7/8"	254JM	5"	4"
GE 4C 200-4	1B0266	1B0266S	2	30 3/4	13 1/2	10 1/3	9 1/2"	9 3/4"	11 13/16"	1/4"	9/16"	4"	12 15/16"	7 1/2	4 1/4"	6 7/8"	256JM	5"	4"
GE 4E 150-4	1B0081	1B0081S	2	26 1/3	21 7/8	11 3/16	10 3/4"	9 3/4"	11 13/16"	1/4"	9/16"	4"	13 1/2"	10	5 1/4"	8 1/2"	215JM	5"	4"
GE 4E 200-4	1B0082	1B0082S	2	31 1/8	21 7/8	12 5/16	10 3/4"	9 3/4"	11 13/16"	1/4"	9/16"	4"	15 1/4"	10	5 1/4"	8 1/2"	256JM	5"	4"
GE 4E 250-4	1B0253	1B0253S	2	33	23 7/8	11	10 3/4"	10 3/4"	11 13/16"	1/4"	9/16"	4"	15 3/16"	10	5 1/4"	8 1/2"	284JM	5"	4"
GE 4E 300-4	1B0083	1B0083S	2	33	21 7/8	11	10 3/4"	11"	14 1/2"	5/16"	9/16"	4"	12 3/8"	10	5 1/4"	8 1/2"	286JM	5"	4"
GE 4E 400-4	1B0084	1B0084S	2	35 9/16	25 7/16	11 7/8	10 3/4"	12 1/2"	14 1/2"	5/16"	9/16"	4"	12 5/16"	10	5 1/4"	8 1/2"	324JM	5"	4"
GE 4E 500-4	1B0085	1B0085S	2	37	25 7/16	11 7/8	10 3/4"	12 1/2"	14 1/2"	5/16"	9/16"	4"	13 7/8"	10	5 1/4"	8 1/2"	326JM	5"	4"
GE 4G 300-4	1B0160	1B0160S	2	35 7/16	26	11 7/8	11 1/4"	12 1/2"	14 1/2"	5/16"	9/16"	4"	12 1/16"	11	4 3/8"	9"	324JM	5"	4"
GE 4G 400-4	1B0161	1B0161S	2	36 7/8	26	11 7/8	11 1/4"	12 1/2"	14 1/2"	5/16"	9/16"	4"	13 9/16"	11	4 3/8"	9"	326JM	5"	4"
GE 4G 500-4	1B0162	1B0162S	2	40 7/16	29 7/16	14 7/8	11 1/4"	14"	17 1/2"	1/4"	9/16"	6"	11 5/8"	11	4 3/8"	9"	364JM	5"	4"
GE 4G 600-4	1B0163	1B0163S	2	43	29 7/16	14 7/8	11 1/4"	14"	17 1/2"	1/4"	9/16"	6"	14 1/8"	11	4 3/8"	9"	365JP	5"	4"
GE 5C 100-4	1B0055	1B0055S	2	26 15/16	21	11 3/16	10 1/4"	10"	11 13/16"	1/4"	9/16"	6"	10 5/8"	8	5 1/4"	7 1/2"	215JM	6"	5"
GE 5C 150-4	1B0056	1B0056S	2	26 5/8	21	11 3/16	10 1/4"	9 3/4"	11 13/16"	1/4"	9/16"	6"	13 1/2"	8	5 1/4"	7 1/2"	215JM	6"	5"
GE 5C 200-4	1B0057	1B0057S	2	32 1/2	21	10 3/8	10 1/4"	9 3/4"	11 13/16"	1/4"	9/16"	4"	15 1/4"	8	5 1/4"	7 1/2"	256JM	6"	5"
GE 5C 250-4	1B0058	1B0058S	2	33 7/16	23 3/4	11	10 1/4"	10 3/4"	11 13/16"	1/4"	9/16"	4"	15 1/4"	8	5 1/4"	7 1/2"	284JM	6"	5"
GE 5C 300-4	1B0059	1B0059S	2	33 7/16	21	11	10 1/4"	11"	14 1/2"	5/16"	9/16"	4"	12 3/8"	8	5 1/4"	7 1/2"	286JM	6"	5"
GE 5E 200-4	1B0086	1B0086S	2	33 1/4	21 7/8	10 5/16	9 1/2"	9 3/4"	11 13/16"	1/4"	9/16"	4"	16 1/8"	10 1/2	5 1/2"	8 1/2"	256JM	6"	5"
GE 5E 250-4	1B0254	1B0254S	2	34 1/16	34 3/8	11 1/16	9 1/2"	10 3/4"	11 13/16"	1/4"	9/16"	4"	16 1/16"	10 1/2	5 1/2"	8 1/2"	284JM	6"	5"
GE 5E 300-4	1B0087	1B0087S	2	34 1/16	21 7/8	11 1/16	9 1/2"	11"	14 1/2"	5/16"	9/16"	4"	13 1/4"	10 1/2	5 1/2"	8 1/2"	286JM	6"	5"
GE 5E 400-4	1B0088	1B0088S	2	36 5/8	25 7/8	11 7/8	9 1/2"	12 1/2"	14 1/2"	5/16"	9/16"	4"	13 1/4"	10 1/2	5 1/2"	8 1/2"	324JM	6"	5"
GE 5E 500-4	1B0089	1B0089S	2	38 1/8	25 7/8	13 7/8	9 1/2"	12 1/2"	14 1/2"	5/16"	9/16"	4"	13 3/4"	10 1/2	5 1/2"	8 1/2"	326JM	6"	5"
GE 5G 600-4	1B0164	1B0164S	2	42 3/16	30 3/4	14 7/8	11"	14"	17 1/2"	1/4"	9/16"	6"	13 3/8"	10	5 3/4"	9 7/8"	364JM	6"	5"
GE 5G 750-4	1B0165	1B0165S	2	44 3/4	30 3/4	14 7/8	11"	14"	17 1/2"	1/4"	9/16"	6"	14 1/8"	10	5 3/4"	9 7/8"	365JP	6"	5"
GE 5G 1000-4	1B0166	1B0166S	2	47 3/4	31	15 7/8	11"	16"	17 1/2"	1/4"	9/16"	6"	16 11/16"	10	5 3/4"	9 7/8"	405JP	6"	5"
GE 5G 1250-4	1B0167	1B0167S	2	52	32 3/8	17	11"	16"	17 1/2"	1/4"	9/16"	6"	16 11/16"	10	5 3/4"	9 7/8"	444JP	6"	5"
GE 6C 150-4	1B0060	1B0060S	2	32 1/16	23 7/16	12 5/16	11"	10"	11 13/16"	1/4"	9/16"	6"	13 1/2"	8 3/8	6 1/8"	8 9/16"	254JM	8"	6"
GE 6C 200-4	1B0061	1B0061S	2	33 3/4	23 7/16	12 5/16	11"	10"	11 13/16"	1/4"	9/16"	6"	13 1/2"	8 3/8	6 1/8"	8 9/16"	256JM	8"	6"
GE 6C 250-4	1B0062	1B0062S	2	34 9/16	25 1/4	13 1/16	11"	10 3/4"	11 13/16"	1/4"	9/16"	4"	16 3/8"	8 3/8	6 1/8"	8 9/16"	284JM	8"	6"
GE 6C 300-4	1B0063	1B0063S	2	34 9/16	23 7/16	13 1/16	11"	11"	14 1/2"	5/16"	9/16"	4"	13 1/2"	8 3/8	6 1/8"	8 9/16"	286JM	8"	6"
GE 6C 400-4	1B0064	1B0064S	2	37 1/8	26 3/4	13 7/8	11"	12 1/2"	14 1/2"	5/16"	9/16"	4"	15"	8 3/8	6 1/8"	8 9/16"	324JM	8"	6"
GE 6E 250-4	1B0090	1B0090S	2	34 5/8	26 1/4	13 1/16	12 1/2"	11"	11 13/16"	1/4"	9/16"	6"	11 13/16"	8 7/8	6 1/8"	9 7/8"	284JM	8"	6"
GE 6E 300-4	1B0255	1B0255S	2	34 5/8	25 1/4	13 1/16	12 1/2"	11"	11 13/16"	1/4"	9/16"	6"	14 1/2"	8 7/8	6 1/8"	9 7/8"	256JM	8"	6"
GE 6E 400-4	1B0091	1B0091S	2	37 3/16	27 3/4	11 7/8	12 1/2"	12 1/2"	14 1/2"	5/16"	9/16"	4"	14"	8 7/8	6 1/8"	9 7/8"	324JM	8"	6"
GE 6E 500-4	1B0256	1B0256S	2	38 11/16	27 3/4	13 7/8	12 1/2"	12 1/2"	17 1/2"	1/4"	9/16"	6"	12 7/8"	8 7/8	6 1/8"	9 7/8"	326JM	8"	6"
GE 6E 600-4	1B0092	1B0092S	2	42 3/16	31 1/16	14 7/8	12 1/2"	14"	17 1/2"	1/4"	9/16"	6"	13 1/2"	8 7/8	6 1/8"	9 7/8"	364JM	8"	6"
GE 6E 750-4	1B0093	1B0093S	2	44 3/4	31 1/16	14 7/8	12 1/2"	14"	17 1/2"	1/4"	9/16"	6"	16 1/4"	8 7/8	6 1/8"	9 7/8"	365JP	8"	6"
GE 6G 1000-4	1B0168	1B0168S	2	47 1/4	32 11/16	15 7/8	13 13/16"	14"	17 1/2"	1/4"	9/16"	6"	15 3/8"	10	6 1/4"	11 1/16"	405JP	8"	6"
GE 6G 1250-4	1B0169	1B0169S	2	51 7/16	34 1/16	17	13 13/16"	18"	17 1/2"	5/16"	5/8"	6"	19 9/16"	10	6 1/4"	11 1/16"	444JP	8"	6"
GE 6G 1500-4	1B0170	1B0170S	2	51 7/16	34 1/16	17	13 13/16"	18"	17 1/2"	5/16"	5/8"	6"	19 9/16"	10	6 1/4"	11 1/16"	445JP	8"	6"
GE 6G 2000-4	1B0171	1B0171S	2	51 11/16	34 1/16	17	13 13/16"	18"	17 1/2"	5/16"	5/8"	6"	19 9/16"	10	6 1/4"	11 1/16"	445JP	8"	6"
GE 8E 600-4	1B0094	1B0094S	2	43 3/4	30 1/2	14 7/8	13 3/8"	14"	17 1/2"	1/4"	9/16"	6"	14 15/16"	13	7"	8"	364JM	10"	8"
GE 8E 750-4	1B0095	1B0095S	2	46 5/16	30 1/2	14 7/8	13 3/8"	14"	17 1/2"	1/4"	9/16"	6"	17 1/2"	13	7"	8"	365JP	10"	8"
GE 8E 1000-4	1B0096	1B0096S	2	49 3/8	30 11/16	15 7/8	13 3/8"	14"	17 1/2"	1/4"	9/16"	6"	18 1/4"	13	7"	8"	405JP	10"	8"
GE 8E 1250-4	1B0097	1B0097S	2	53 1/2	32 1/16	17	13 3/8"	16"	17 1/2"	1/4"	9/16"	6"	21 11/16"	13	7"	8"	444JP	10"	8"

Motor dimensions may vary by motor manufacturer.
 Technical specifications are subject to change without prior notice.

Sectional GU Series

GS Line
Frame Mounted Pumps



www.wdmpumps.com

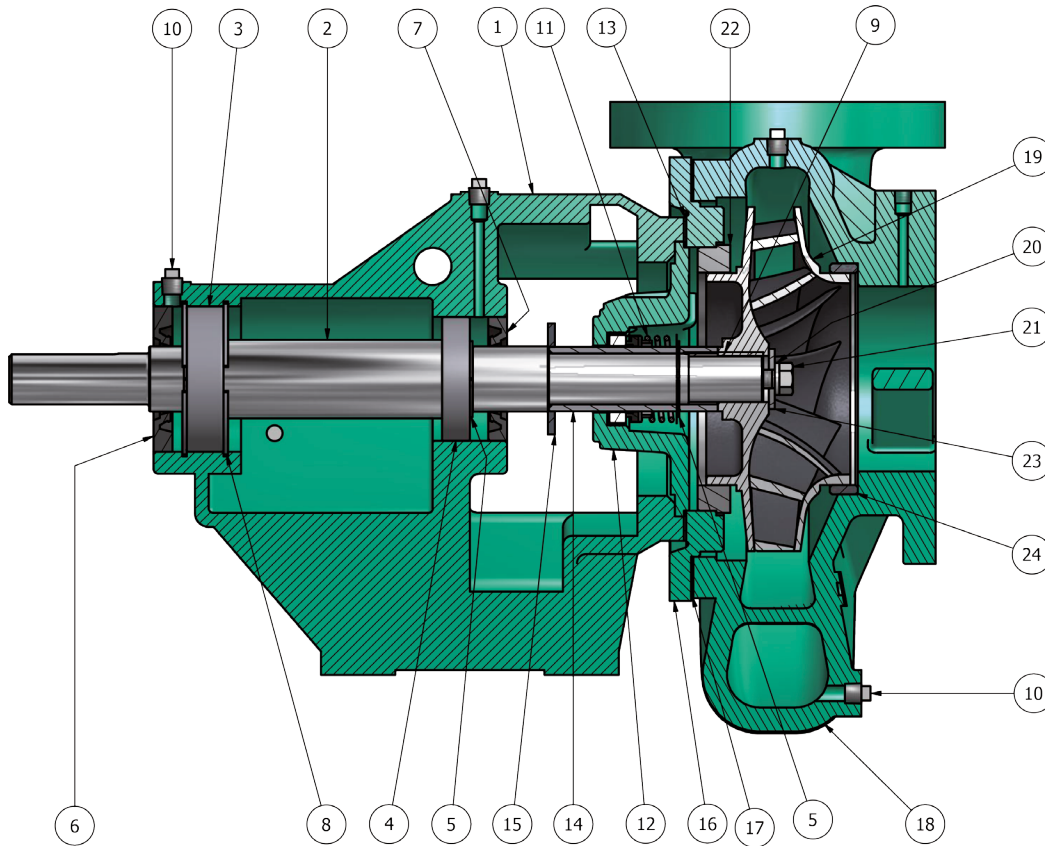

ITEM	QTY	DESCRIPTION	MATERIAL
1	1	BEARING FRAME	CAST IRON ASTM A48
2	1	SHAFT	STEEL ASTM 4140
3	1	BEARING, OUTBOARD	STEEL
4	1	BEARING, INBOARD	STEEL
5	4	RETAINING RING	RUBBER
6	1	LIP SEAL	NITRILE RUBBER
7	1	LIP SEAL	NITRILE RUBBER
8	2	SEEGER RING	CARBON STEEL
9	1	KEY IMPELLER	CARBON STEEL
10	11	PLUG GREASE	CARBON STEEL
11	1	SHAFT SEAL	CARBON / CERAMIC / BUNA
12	1	SEAL HOUSING	CAST IRON ASTM A48

ITEM	QTY	DESCRIPTION	MATERIAL
13	1	GASKET, BACKPLATE	STANDARD PAPER GASKET
14	1	SHAFT SLEEVE	STAINLESS STEEL AISI 304
15	1	SLINGER	RUBBER
16	1	BACKPLATE*	CAST IRON ASTM A48
17	1	GASKET CASING	STANDARD PAPER GASKET
18	1	CASING	CAST IRON ASTM A48
19	1	IMPELLER	CAST IRON ASTM A48
20	1	LOCK WASHER	STAINLESS STEEL AISI 304
21	1	BOLT	STAINLESS STEEL AISI 304
22	1	WEAR RING*	CAST IRON ASTM A48 OR BRONZE
23	1	WASHER	STAINLESS STEEL AISI 304
24	1	CASE WEAR RING*	CAST IRON ASTM A48 OR BRONZE

* This part could change depending of the reference, please contact our sales department in order to clarify any dudas.

Technical specifications are subject to change without prior notice.

Drawing 1

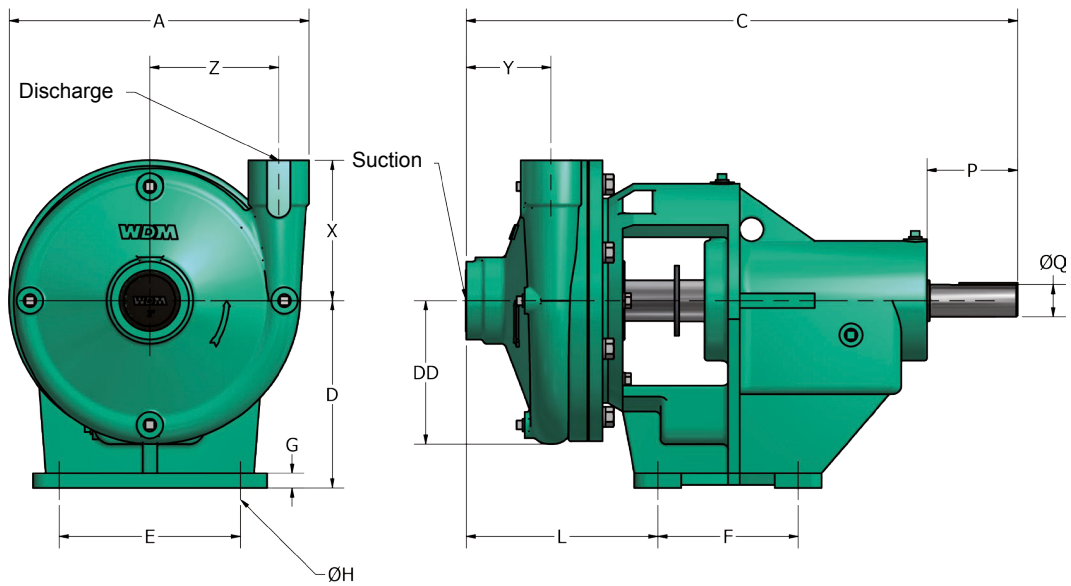

Drawing 2

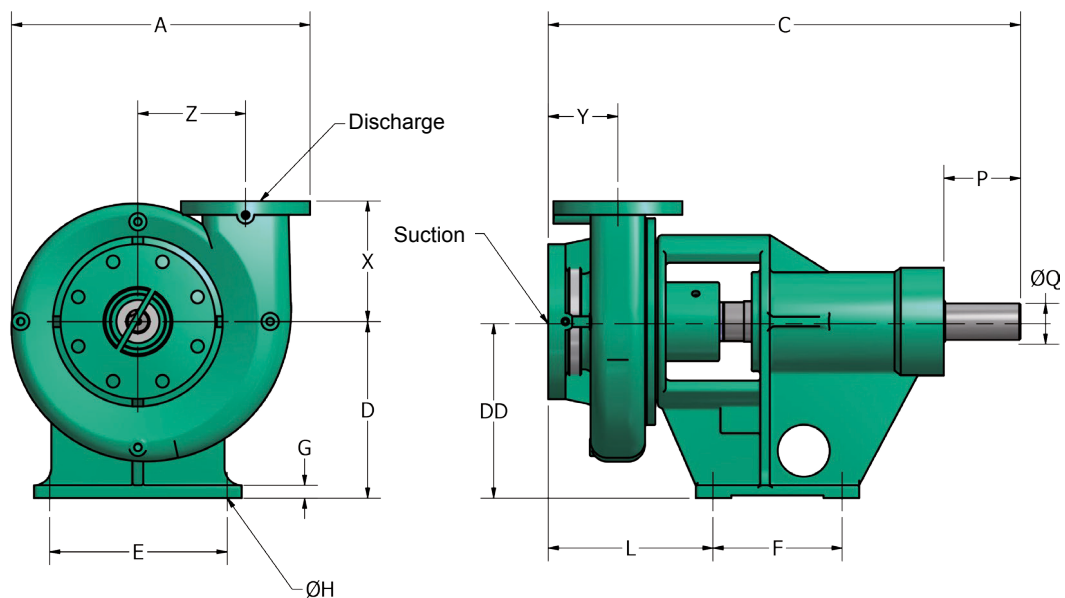

GU 3600 rpm / 2 poles (in)																				
MODEL	Ref. Cast Iron Imp.	Ref. Stainless Steel Imp.	Drawing	C	A	D	DD	E	F	G	H	L	P	Q	X	Frame	Y	Z	Suc	Disc
GU 1.5C 2	1B0101	1B0101S	1	23 1/2	12 7/8	8	6 3/16"	7 3/4"	6"	5/8"	9/16"	8 1/16"	3 7/8"	1 3/8"	6	N/A	3 5/8"	5 1/2"	2"	1 1/2"
GU 1.5D 2	1B0101	1B0101S	1	23 1/2	12 7/8	8	6 3/16"	7 3/4"	6"	5/8"	9/16"	8 1/16"	3 7/8"	1 3/8"	6	N/A	3 5/8"	5 1/2"	2"	1 1/2"
GU 2B 2	1B0105	1B0105S	1	23 7/8	11 1/4	8	5 1/8"	7 3/4"	6"	5/8"	9/16"	8 1/2"	3 7/8"	1 3/8"	5 3/8	N/A	4"	4 1/2"	2 1/2"	2"
GU 2C 2	1B0107	1B0107S	1	24	13 7/16	8	6 5/8"	7 3/4"	6"	5/8"	9/16"	8 1/8"	3 7/8"	1 3/8"	6	N/A	3 3/4"	5 3/4"	2 1/2"	2"
GU 2.5B 2	1B0109	1B0109S	2	24 1/2	13	8	5 3/8"	7 3/4"	6"	5/8"	9/16"	8 1/2"	3 7/8"	1 3/8"	5 5/8	N/A	3 5/8"	4 1/4"	3"	2 1/2"
GU 2.5C 2	1B0111	1B0111S	2	24 1/16	16 3/16	8	6 3/4"	7 3/4"	6"	5/8"	9/16"	9 1/4"	3 7/8"	1 3/8"	6 3/4	N/A	4 1/8"	6"	3"	2 1/2"
GU 3B 2	1B0113	1B0113S	2	24 7/8	14 3/8	8	5 7/8"	7 3/4"	6"	5/8"	9/16"	9 5/16"	3 7/8"	1 3/8"	6	N/A	4 1/8"	5"	4"	3"
GU 3C 2	1B0115	1B0115S	2	24 1/16"	17 7/16	8	8"	7 3/4"	6"	5/8"	9/16"	8 1/2"	3 7/8"	1 3/8"	7	N/A	4"	6 1/4"	4"	3"
GU 4B 2	1B0120	1B0120S	2	24 11/16"	17 7/16	8	8"	7 3/4"	6"	5/8"	9/16"	9 1/8"	3 7/8"	1 3/8"	7 1/4	N/A	4 3/8"	6 1/4"	5"	4"
GU 4C 2	1B0117	1B0117S	2	24 7/8"	19 3/8	9 5/8	9 1/2"	7 3/4"	6"	5/8"	9/16"	9"	3 7/8"	1 3/8"	7 1/2	N/A	4 1/4"	6 7/8"	5"	4"

GU 1800 rpm / 4 poles (in)																				
MODEL	Ref. Cast Iron Imp.	Ref. Stainless Steel Imp.	Drawing	C	A	D	DD	E	F	G	H	L	P	Q	X	Frame	Y	Z	Suc	Disc
GU 1.5C 1	1B0100	1B0100S	1	18 5/16	12 7/8	6 1/4	6 3/16"	5 1/2"	4 1/2"	5/8"	7/16"	7 1/8"	2 1/4"	7/8"	6	N/A	3 5/8"	5 1/2"	2"	1 1/2"
GU 1.5D 1	1B0102	1B0102S	1	18 5/16	12 7/8	6 1/4	6 3/16"	5 1/2"	4 1/2"	5/8"	7/16"	7 1/8"	2 1/4"	7/8"	6	N/A	3 5/8"	5 1/2"	2"	1 1/2"
GU 2B 1	1B0104	1B0104S	1	18 3/4	11 1/16	6 1/4	5 1/8"	5 1/2"	4 1/2"	5/8"	7/16"	7 3/8"	2 1/4"	7/8"	5 3/8	N/A	4"	4 1/2"	2 1/2"	2"
GU 2C 1	1B0106	1B0106S	1	18 5/8	13 7/16	6 1/4	6 5/8"	5 1/2"	4 1/2"	5/8"	7/16"	7 1/4"	2 1/4"	7/8"	6	N/A	3 3/4"	5 3/4"	2 1/2"	2"
GU 2E 1	1B0124	1B0124S	1	19 1/2	15 3/4	6 1/4	7 1/2"	5 1/2"	4 1/2"	5/8"	7/16"	8 1/4"	2 1/4"	7/8"	8	N/A	4"	6 3/4"	2 1/2"	2"
GU 2.5B 1	1B0108	1B0108S	2	18 3/4	13	6 1/4	5 3/8"	5 1/2"	4 1/2"	5/8"	7/16"	7 5/8"	2 1/4"	7/8"	5 5/8	N/A	3 5/8"	4 1/4"	3"	2 1/2"
GU 2.5C 1	1B0110	1B0110S	2	19 5/8	16 3/16	6 1/4	6 3/4"	5 1/2"	4 1/2"	5/8"	7/16"	8 1/4"	2 1/4"	7/8"	6 3/4	N/A	4 1/8"	6"	3"	2 1/2"
GU 2.5E 2	1B0125	1B0125S	2	24 11/16	15 3/4	8	7 5/8"	7 3/4"	6"	5/8"	9/16"	8 3/8"	3 7/8"	1 3/8"	8	N/A	3 3/4"	7"	3"	2 1/2"
GU 3B 1	1B0112	1B0112S	2	19 5/16	14 3/8	6 1/4	5 7/8"	5 1/2"	4 1/2"	5/8"	7/16"	8 7/16"	2 1/4"	7/8"	6	N/A	4 1/8"	5"	4"	3"
GU 3C 1	1B0114	1B0114S	2	18 15/16	17 7/16	8	8"	5 1/2"	4 1/2"	5/8"	7/16"	7 5/8"	2 1/4"	7/8"	7	N/A	4"	6 1/4"	4"	3"
GU 3E 2	1B0126	1B0126S	2	19	24 5/8	8 3/8	8 3/8"	7 3/4"	6"	5/8"	9/16"	9"	3 7/8"	1 3/8"	8 5/8	N/A	3 7/8"	7 1/4"	4"	3"
GU 3F 2	1B0127	1B0127S	2	24 5/8	19 1/16	8 7/16	8 3/8"	7 3/4"	6"	5/8"	9/16"	9"	3 7/8"	1 3/8"	8 5/8	N/A	3 7/8"	7 1/4"	4"	3"
GU 3G 3	1B0151	1B0151S	2	29 1/16	21 3/4	10 1/4	10"	10 1/4"	7 1/2"	3/4"	11/16"	8 3/4"	3 7/8"	1 3/8"	9 3/4	N/A	3 3/4"	8"	4"	3"
GU 4B 1	1B0119	1B0119S	2	19 1/4	17 7/16	8 1/16	8"	5 1/2"	4 1/2"	5/8"	7/16"	8 1/4"	2 1/4"	7/8"	7 1/4	N/A	4 3/8"	6 1/4"	5"	4"
GU 4C 1	1B0116	1B0116S	2	19 9/16	19 3/8	9 9/16	9 1/2"	5 1/2"	4 1/2"	5/8"	7/16"	8 1/8"	2 1/4"	7/8"	7 1/2	N/A	4 1/4"	6 7/8"	5"	4"
GU 4C 3	1B0257	1B0257S	2	27 11/16	17 1/2	10 1/4	9 1/2"	10 1/4"	7 1/2"	3/4"	11/16"	10 1/2"	4 1/2"	2 1/8"	7	N/A	4 1/4"	6 7/8"	5"	4"
GU 4E 2	1B0128	1B0128S	2	26 3/16	21 7/8	10 3/4	10 3/4"	7 3/4"	6"	5/8"	9/16"	10 5/16"	3 7/8"	1 3/8"	10	N/A	5 1/4"	8 1/2"	5"	4"
GU 4G 3	1B0152	1B0152S	2	29 7/8	24 1/4	11 1/16	11 1/4"	10 1/4"	7 1/2"	3/4"	11/16"	10 9/16"	4 1/2"	2 1/8"	11	N/A	4 3/8"	9"	5"	4"
GU 5C 2	1B0122	1B0122S	2	26 11/16	21	10 3/8	10 1/4"	7 3/4"	6"	5/8"	9/16"	11"	3 7/8"	1 3/8"	8	N/A	5 1/4"	7 1/2"	6"	5"
GU 5E 2	1B0129	1B0129S	2	27 1/4	21 7/8	9 7/16	9 1/2"	7 3/4"	6"	5/8"	9/16"	11"	3 7/8"	1 3/8"	10 1/2	N/A	5 1/2"	8 1/2"	6"	5"
GU 5G 4	1B0153	1B0153S	2	32 3/4	25 3/8	11	11"	10 5/16"	10"	3/4"	3/4"	12 7/16"	4 1/2"	2 3/8"	10	N/A	5 3/4"	9 7/8"	6"	5"
GU 6C 2	1B0123	1B0123S	2	27 3/4	23 7/16	12 5/16	11"	7 3/4"	6"	5/8"	9/16"	12 1/8"	3 7/8"	1 3/8"	8 3/8	N/A	6 1/8"	8 9/16"	8"	6"
GU 6E 2	1B0130	1B0130S	2	27 3/4	25 1/4	12 3/16	12 1/2"	7 3/4"	6"	5/8"	9/16"	12 3/8"	3 7/8"	1 3/8"	8 7/8	N/A	6 1/8"	9 7/8"	8"	6"
GU 6G 4	1B0154	1B0154S	2	33 7/8	28 1/4	13 3/4	13 13/16"	10 5/16"	10"	3/4"	3/4"	14 3/8"	4 1/2"	2 3/8"	10	N/A	6 1/4"	11 1/16"	8"	6"
GU 8E 3	1B0131	1B0131S	2	32 5/16	25 5/16	13 7/16	13 3/8"	10 1/4"	7 1/2"	3/4"	11/16"	14 3/8"	4 1/2"	2 1/8"	13	N/A	7"	8"	10"	8"

Motor dimensions may vary by motor manufacturer.
 Technical specifications are subject to change without prior notice.

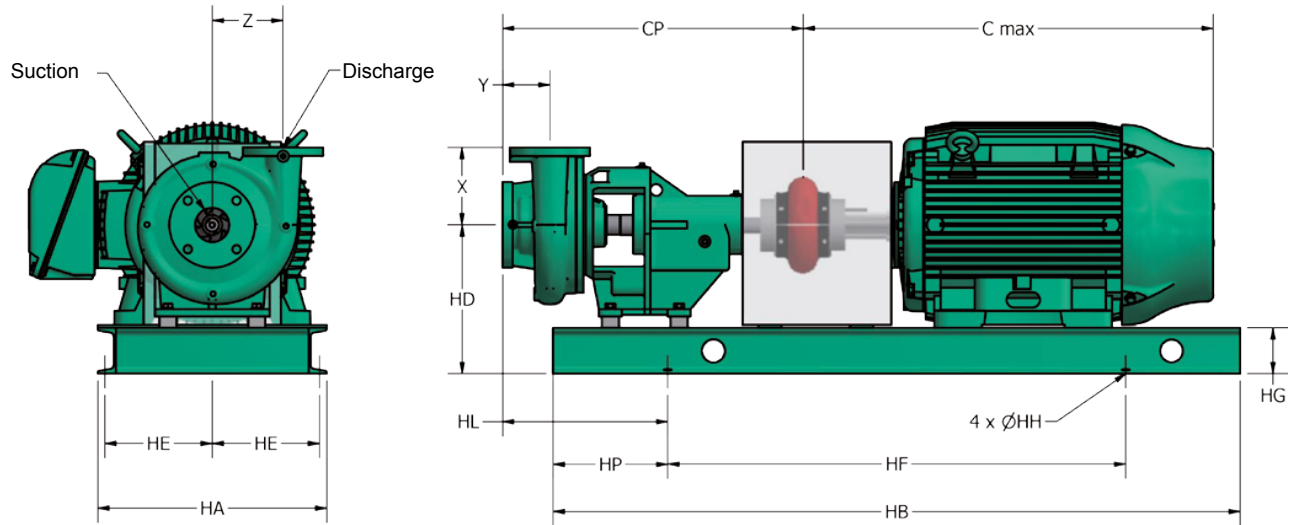

Dimensions (in)																				
MODEL	Ref. Cast Iron Imp.	Ref. Stainless Steel Imp.	Suc	Desc	Power (HP)	Frame	HE	HA	Z	HD	X	Y	CP	C MAX"	HG	HH	HF	HB	HP	HL
GU 1.5C 1 15-4-WE2	113475	113475S	2" NPT	1.5" NPT	1.5	145T	5.375"	12"	5.499"	9.25"	6"	3.625"	23.662"	13.796"	3"	9/16"	22.91"	26.91"	2"	8.72"
GU 1.5C 1 20-4-WE2	113476	113476S	2" NPT	1.5" NPT	2	145T	5.375"	12"	5.499"	9.25"	6"	3.625"	23.662"	13.796"	3"	9/16"	22.91"	26.91"	2"	8.72"
GU 1.5C 1 30-4-WE3	113477	113477S	2" NPT	1.5" NPT	3	182T	5.375"	12"	5.499"	9.25"	6"	3.625"	23.372"	16.02"	3"	9/16"	24.81"	28.81"	2"	8.72"
GU 1.5C 1 50-4-WE3	113478	113478S	2" NPT	1.5" NPT	5	184T	5.375"	12"	5.499"	9.25"	6"	3.625"	23.372"	16.02"	3"	9/16"	24.81"	28.81"	2"	8.72"
GU 1.5C 2 100-WE3	113479	113479S	2" NPT	1.5" NPT	10	215	6.375"	15"	5.499"	11"	6"	3.625"	29.722"	19.431"	3"	9/16"	32.71"	36.71"	2"	9.68"
GU 1.5C 2 150-WE4	113480	113480S	2" NPT	1.5" NPT	15	254T	6.375"	15"	5.499"	11"	6"	3.625"	29.712"	24.647"	3"	9/16"	31.11"	42.11"	5.5"	13.18"
GU 1.5C 2 200-WE4	113481	113481S	2" NPT	1.5" NPT	20	256T	6.375"	15"	5.499"	11"	6"	3.625"	29.712"	24.647"	3"	9/16"	35.11"	41.11"	3"	11.18"
GU 1.5C 2 250-WE5	113482	113482S	2" NPT	1.5" NPT	25	284TS	6.375"	15"	5.499"	11"	6"	3.625"	29.962"	26.711"	3"	9/16"	38.21"	44.21"	3"	10.68"
GU 1.5D 1 20-4-WE2	113483	113483S	2" NPT	1.5" NPT	2	145T	5.375"	12"	5.499"	9.25"	6"	3.625"	23.694"	13.796"	3"	9/16"	22.91"	26.91"	2"	8.75"
GU 1.5D 1 30-4-WE3	113484	113484S	2" NPT	1.5" NPT	3	182T	5.375"	12"	5.499"	9.25"	6"	3.625"	23.404"	16.02"	3"	9/16"	24.81"	28.81"	2"	8.75"
GU 1.5D 1 50-4-WE3	113485	113485S	2" NPT	1.5" NPT	5	184T	5.375"	12"	5.499"	9.25"	6"	3.625"	23.404"	16.02"	3"	9/16"	24.81"	28.81"	2"	8.75"
GU 1.5D 1 75-4-WE3	113486	113486S	2" NPT	1.5" NPT	7.5	213T	6.375"	14"	5.499"	9.25"	6"	3.625"	23.404"	19.431"	3"	9/16"	25.51"	32.51"	3.5"	10.25"
GU 1.5D 2 200-WE4	113487	113487S	2" NPT	1.5" NPT	20	256T	6.375"	15"	5.499"	11"	6"	3.625"	29.712"	24.647"	3"	9/16"	34.11"	42.11"	4"	11.68"
GU 1.5D 2 250-WE5	113488	113488S	2" NPT	1.5" NPT	25	284TS	6.375"	15"	5.499"	11"	6"	3.625"	29.962"	26.711"	3"	9/16"	38.21"	44.21"	3"	10.68"
GU 1.5D 2 300-WE5	113489	113489S	2" NPT	1.5" NPT	30	286TS	6.375"	15"	5.499"	11"	6"	3.625"	29.962"	26.711"	3"	9/16"	38.21"	44.21"	3"	10.68"
GU 1.5D 2 400-WE10	113490	113490S	2" NPT	1.5" NPT	40	324TS	8.375"	18"	5.499"	12"	6"	3.625"	29.967"	29.775"	4"	9/16"	40.38"	47.38"	3.5"	11.11"
GU 1.5D 2 500-WE10	113491	113491S	2" NPT	1.5" NPT	50	326TS	8.375"	18"	5.499"	12"	6"	3.625"	29.967"	29.775"	4"	9/16"	40.38"	47.38"	3.5"	11.11"
GU 1.5D 2 600-WE10	113492	113492S	2" NPT	1.5" NPT	60	364TS	9.375"	21"	5.499"	12"	6"	3.625"	29.967"	33.673"	4"	9/16"	46.08"	50.08"	2"	9.61"
GU 2B 1 10-4-WE2	113494	113494S	2.5" NPT	2" NPT	1	143T	5.375"	12"	4.467"	9.25"	5.304"	4.001"	23.879"	13.796"	3"	9/16"	22.91"	26.91"	2"	8.83"
GU 2B 1 15-4-WE2	113495	113495S	2.5" NPT	2" NPT	1.5	145T	5.375"	12"	4.467"	9.25"	5.304"	4.001"	23.879"	13.796"	3"	9/16"	22.91"	26.91"	2"	8.93"
GU 2B 1 20-4-WE2	113496	113496S	2.5" NPT	2" NPT	2	145T	5.375"	12"	4.467"	9.25"	5.304"	4.001"	23.879"	13.796"	3"	9/16"	22.91"	26.91"	2"	8.93"
GU 2B 1 30-4-WE3	113497	113497S	2.5" NPT	2" NPT	3	182T	5.375"	12"	4.467"	9.25"	5.304"	4.001"	23.589"	16.02"	3"	9/16"	24.81"	28.81"	2"	8.83"
GU 2B 2 75-WE3	113498	113498S	2.5" NPT	2" NPT	7.5	213T	6.375"	15"	4.467"	11"	5.304"	4.001"	30.036"	19.431"	3"	9/16"	32.71"	36.71"	2"	10"
GU 2B 2 100-WE3	113499	113499S	2.5" NPT	2" NPT	10	215T	6.375"	15"	4.467"	11"	5.304"	4.001"	30.036"	19.431"	3"	9/16"	32.71"	36.71"	2"	10"

F = Flanged / NPT = Threaded

Technical specifications are subject to change without prior notice.

Dimensions (in)																				
MODEL	Ref. Cast Iron Imp.	Ref. Stainless Steel Imp.	Suc	Disc	Power (HP)	Frame	HE	HA	Z	HD	X	Y	CP	C MAX"	HG	HH	HF	HB	HP	HL
GU 2B 2 150-WE4	113500	113500S	2.5" NPT	2" NPT	15	254T	6.375"	15"	4.467"	11"	5.304"	4.001"	30.026"	24.647"	3"	9/16"	31.11"	42.11"	5.5"	13.5"
GU 2B 2 200-WE4	113501	113501S	2.5" NPT	2" NPT	20	256T	6.375"	15"	4.467"	11"	5.304"	4.001"	30.026"	24.647"	3"	9/16"	31.11"	42.11"	5.5"	13.5"
GU 2B 2 250-WE5	113502	113502S	2.5" NPT	2" NPT	25	284TS	6.375"	15"	4.467"	11"	5.304"	4.001"	30.276"	26.711"	3"	9/16"	38.21"	44.21"	3"	11"
GU 2C 1 20-4-WE2	113503	113503S	2.5" NPT	2" NPT	2	145T	5.375"	12"	5.688"	9.25"	5.304"	3.75"	24.129"	13.796"	3"	9/16"	22.91"	26.91"	2"	9.18"
GU 2C 1 30-4-WE3	113504	113504S	2.5" NPT	2" NPT	3	182T	5.375"	12"	5.688"	9.25"	5.304"	3.75"	23.839"	16.02"	3"	9/16"	24.81"	28.81"	2"	9.18"
GU 2C 1 50-4-WE3	113505	113505S	2.5" NPT	2" NPT	5	184T	5.375"	12"	5.688"	9.25"	5.304"	3.75"	23.839"	16.02"	3"	9/16"	24.81"	28.81"	2"	9.18"
GU 2C 1 75-4-WE3	113506	113506S	2.5" NPT	2" NPT	7.5	213T	6.375"	14"	5.688"	9.25"	5.304"	3.75"	23.839"	19.431"	3"	9/16"	25.51"	32.51"	3.5"	10.68"
GU 2C 2 200-WE4	113507	113507S	2.5" NPT	2" NPT	20	256T	6.375"	15"	5.688"	11"	6"	3.75"	30.167"	24.647"	3"	9/16"	31.11"	42.11"	5.5"	13.64"
GU 2C 2 250-WE5	113508	113508S	2.5" NPT	2" NPT	25	284TS	6.375"	15"	5.688"	11"	6"	3.75"	30.417"	26.711"	3"	9/16"	38.21"	44.21"	3"	11.14"
GU 2C 2 300-WE5	113509	113509S	2.5" NPT	2" NPT	30	286TS	6.375"	15"	5.688"	11"	6"	3.75"	30.417"	26.711"	3"	9/16"	38.21"	44.21"	3"	11.14"
GU 2C 2 400-WE10	113510	113510S	2.5" NPT	2" NPT	40	324TS	8.375"	18"	5.688"	12"	6"	3.75"	30.422"	29.775"	4"	9/16"	40.38"	47.38"	3.5"	11.57"
GU 2C 2 500-WE10	113511	113511S	2.5" NPT	2" NPT	50	326TS	8.375"	18"	5.688"	12"	6"	3.75"	30.422"	29.775"	4"	9/16"	40.38"	47.38"	3.5"	11.57"
GU 2C 2 600-WE10	113512	113512S	2.5" NPT	2" NPT	60	364TS	9.375"	21"	5.688"	12"	6"	3.75"	30.422"	33.673"	4"	9/16"	46.08"	50.08"	2"	10.17"
GU 2E 1 50-4-WE3	113513	113513S	2.5" NPT	2" NPT	5	184T	5.375"	12"	6.75"	9.25"	8"	4"	24.534"	16.02"	3"	9/16"	24.81"	26.81"	1"	9.88"
GU 2E 1 75-4-WE3	113514	113514S	2.5" NPT	2" NPT	7.5	213T	6.375"	14"	6.75"	9.25"	8"	4"	24.534"	19.431"	3"	9/16"	25.51"	32.51"	3.5"	11.38"
GU 2E 1 100-4-WE4	113515	113515S	2.5" NPT	2" NPT	10	215T	6.375"	14"	6.75"	9.25"	8"	4"	24.534"	19.431"	3"	9/16"	28.51"	32.51"	2"	9.88"
GU 2E 1 150-4-WE5	113516	113516S	2.5" NPT	2" NPT	15	254T	6.375"	15"	6.75"	9.25"	8"	4"	24.774"	24.023"	3"	9/16"	32.51"	36.51"	2"	9.88"
GU 2.5B 1 10-4-WE2	113517	113517S	3" F	2.5" F	1	143T	5.375"	12"	4.25"	9.25"	5.625"	3643"	24.083"	13.796"	3"	9/16"	22.91"	26.91"	2"	9.14"
GU 2.5B 1 15-4-WE2	113518	113518S	3" F	2.5" F	1.5	145T	5.375"	12"	4.25"	9.25"	5.625"	3643"	24.083"	13.796"	3"	9/16"	22.91"	26.91"	2"	9.14"
GU 2.5B 1 20-4-WE2	113519	113519S	3" F	2.5" F	2	145T	5.375"	12"	4.25"	9.25"	5.625"	3643"	24.083"	13.796"	3"	9/16"	22.91"	26.91"	2"	9.14"
GU 2.5B 1 30-4-WE3	113520	113520S	3" F	2.5" F	3	182T	5.375"	12"	4.25"	9.25"	5.625"	3643"	23.793"	16.02"	3"	9/16"	24.81"	28.81"	2"	9.14"
GU 2.5B 2 75-WE3	113521	113521S	3" F	2.5" F	7.5	213T	6.375"	15"	4.25"	11"	5.625"	3643"	30.086"	19.431"	3"	9/16"	29.71"	36.71"	3.5"	11.55"
GU 2.5B 2 100-WE3	113522	113522S	3" F	2.5" F	10	215T	6.375"	15"	4.25"	11"	5.625"	3643"	30.086"	19.431"	3"	9/16"	29.71"	36.71"	3.5"	11.55"
GU 2.5B 2 150-WE4	113523	113523S	3" F	2.5" F	15	254T	6.375"	15"	4.25"	11"	5.625"	3643"	30.076"	24.647"	3"	9/16"	33.11"	42.11"	4.5"	12.55"
GU 2.5B 2 200-WE4	113524	113524S	3" F	2.5" F	20	256T	6.375"	15"	4.25"	11"	5.625"	3643"	30.076"	24.647"	3"	9/16"	33.11"	42.11"	4.5"	12.55"
GU 2.5B 2 250-WE5	113525	113525S	3" F	2.5" F	25	284TS	6.375"	15"	4.25"	11"	5.625"	3643"	30.326"	26.711"	3"	9/16"	38.21"	44.21"	3"	11.05"
GU 2.5B 2 300-WE5	113526	113526S	3" F	2.5" F	30	286TS	6.375"	15"	4.25"	11"	5.625"	3643"	30.326"	26.711"	3"	9/16"	38.21"	44.21"	3"	11.05"
GU 2.5C 1 20-4-WE2	113527	113527S	3" F	2.5" F	2	145T	5.375"	12"	6.188"	9.25"	6.75"	4125"	24.935"	13.796"	3"	9/16"	22.91"	26.81"	1.95"	9.99"
GU 2.5C 1 30-4-WE3	113528	113528S	3" F	2.5" F	3	182T	5.375"	12"	6.188"	9.25"	6.75"	4125"	24.645"	16.02"	3"	9/16"	24.81"	28.81"	2"	9.99"
GU 2.5C 1 50-4-WE3	113529	113529S	3" F	2.5" F	5	184T	5.375"	12"	6.188"	9.25"	6.75"	4125"	24.645"	16.02"	3"	9/16"	24.81"	28.81"	2"	9.99"
GU 2.5C 1 75-4-WE3	113530	113530S	3" F	2.5" F	7.5	213T	6.375"	14"	6.188"	9.25"	6.75"	4125"	24.645"	19.431"	3"	9/16"	28.51"	32.51"	2"	9.99"
GU 2.5C 2 200-WE4	113531	113531S	3" F	2.5" F	20	256T	6.375"	15"	6.188"	11"	6.938"	4125"	30.928"	24.647"	3"	9/16"	33.11"	42.11"	4.5"	13.4"
GU 2.5C 2 250-WE5	113532	113532S	3" F	2.5" F	25	284TS	6.375"	15"	6.188"	11"	6.938"	4125"	31.178"	26.711"	3"	9/16"	35.21"	44.21"	4.5"	13.4"
GU 2.5C 2 300-WE5	113533	113533S	3" F	2.5" F	30	286TS	6.375"	15"	6.188"	11"	6.938"	4125"	31.178"	26.711"	3"	9/16"	35.21"	44.21"	4.5"	13.4"
GU 2.5C 2 400-WE10	113534	113534S	3" F	2.5" F	40	324TS	8.375"	18"	6.188"	12"	6.938"	4125"	31.183"	29.775"	4"	9/16"	40.38"	47.38"	3.5"	12.33"
GU 2.5C 2 500-WE10	113535	113535S	3" F	2.5" F	50	326TS	8.375"	18"	6.188"	12"	6.938"	4125"	31.183"	29.775"	4"	9/16"	40.38"	47.38"	3.5"	12.33"
GU 2.5C 2 600-WE10	113536	113536S	3" F	2.5" F	60	364TS	9.375"	21"	6.188"	12"	6.938"	4125"	31.183"	33.673"	4"	9/16"	46.08"	50.08"	2"	10.83"
GU 2.5C 2 750-WE10	113537	113537S	3" F	2.5" F	75	365TS	9.375"	21"	6.188"	12"	6.938"	4125"	31.183"	33.673"	4"	9/16"	46.08"	50.08"	2"	10.83"
GU 2.5E 2 75-4-WE3	113538	113538S	3" F	2.5" F	7.5	213T	6.375"	15"	6.875"	11"	8.375"	3.85"	30.716"	19.431"	3"	9/16"	29.71"	36.71"	3.5"	12.18"
GU 2.5E 2 100-4-WE4	113539	113539S	3" F	2.5" F	10	215T	6.375"	15"	6.875"	11"	8.375"	3.85"	30.716"	19.431"	3"	9/16"	29.71"	36.71"	3.5"	12.18"
GU 2.5E 2 150-4-WE4	113540	113540S	3" F	2.5" F	15	254T	6.375"	15"	6.875"	11"	8.375"	3.85"	30.706"	24.647"	3"	9/16"	33.11"	42.11"	4.5"	13.18"
GU 2.5E 2 200-4-WE4	113541	113541S	3" F	2.5" F	20	256T	6.375"	15"	6.875"	11"	8.375"	3.85"	30.706"	24.647"	3"	9/16"	33.11"	42.11"	4.5"	13.18"
GU 3B 1 15-4-WE2	113542	113542S	4" F	3" F	1.5	145T	5.375"	12"	4.875"	9.25"	6"	4125"	24.645"	13.796"	3"	9/16"	22.91"	26.91"	2"	9.7"
GU 3B 1 20-4-WE2	113543	113543S	4" F	3" F	2	145T	5.375"	12"	4.875"	9.25"	6"	4125"	24.645"	13.796"	3"	9/16"	22.91"	26.91"	2"	9.7"
GU 3B 1 30-4-WE3	113544	113544S	4" F	3" F	3	182T	5.375"	12"	4.875"	9.25"	6"	4125"	24.355"	16.02"	3"	9/16"	24.81"	28.81"	2"	9.7"
GU 3B 1 50-4-WE3	113545	113545S	4" F	3" F	5	184T	5.375"	12"	4.875"	9.25"	6"	4125"	24.355"	16.02"	3"	9/16"	24.81"	28.81"	2"	9.7"
GU 3B 2 100-WE3	113546	113546S	4" F	3" F	10	215T	6.375"	15"	4.875"	11"	6"	4125"	30.648"	19.431"	3"	9/16"	29.71"	36.71"	3.5"	12.11"
GU 3B 2 150-WE4	113547	113547S	4" F	3" F	15	254T	6.375"	15"	4.875"	11"	6"	4125"	30.638"	24.647"	3"	9/16"	33.11"	42.11"	4.5"	13.11"
GU 3B 2 200-WE4	113548	113548S	4" F	3" F	20	256T	6.375"	15"	4.875"	11"	6"	4125"	30.638"	24.647"	3"	9/16"	33.11"	42.11"	4.5"	13.11"
GU 3B 2 250-WE5	113549	113549S	4" F	3" F	25	284TS	6.375"	15"	4.875"	11"	6"	4125"	30.888"	26.711"	3"	9/16"	35.21"	44.21"	4.5"	13.11"
GU 3B 2 300-WE5	113550	113550S	4" F	3" F	30	286TS	6.375"	15"	4.875"	11"	6"	4125"	30.888"	26.711"	3"	9/16"	35.21"	44.21"	4.5"	13.11"
GU 3B 2 400-WE10	113551	113551S	4" F	3" F	40"	324TS	8.375"	18"	4.875"	12"	6"	4125"	30.893"	29.775"	4"	9/16"	40.38"	47.38"	3.5"	3.5"

F = Flanged / NPT = Threaded

Technical specifications are subject to change without prior notice.

Dimensions (in)																				
MODEL	Ref. Cast Iron Imp.	Ref. Stainless Steel Imp.	Suc	Disc	Power (HP)	Frame	HE	HA	Z	HD	X	Y	CP	C MAX"	HG	HH	HF	HB	HP	HL
GU 3C 1 30-4-WE3	113552	113552S	4" F	3" F	3	182T	5.375"	12"	6.188"	9.25"	7"	4"	23.897"	16.02"	3"	9/16"	24.81"	28.81"	2"	9.24"
GU 3C 1 50-4-WE3	113553	113553S	4" F	3" F	5	184T	5.375"	12"	6.188"	9.25"	7"	4"	23.897"	16.02"	3"	9/16"	24.81"	28.81"	2"	9.24"
GU 3C 1 75-4-WE3	113554	113554S	4" F	3" F	7.5	213T	6.375"	14"	6.188"	9.25"	7"	4"	23.897"	19.431"	3"	9/16"	28.51"	32.51"	2"	9.24"
GU 3C 1 100-4-WE4	113555	113555S	4" F	3" F	10	215T	6.375"	14"	6.188"	9.25"	7"	4"	23.897"	19.431"	3"	9/16"	28.51"	32.51"	2"	9.24"
GU 3C 2 250-WE5	113556	113556S	4" F	3" F	25	284TS	6.375"	15"	6.188"	11"	7"	4"	29.521"	26.711"	3"	9/16"	35.21"	44.21"	4.5"	11.74"
GU 3C 2 300-WE5	113557	113557S	4" F	3" F	30	286TS	6.375"	15"	6.188"	11"	7"	4"	29.521"	26.711"	3"	9/16"	35.21"	44.21"	4.5"	11.74"
GU 3C 2 400-WE10	113558	113558S	4" F	3" F	40	324TS	8.375"	18"	6.188"	12"	7"	4"	29.526"	29.775"	4"	9/16"	40.38"	47.38"	3.5"	10.67"
GU 3C 2 500-WE10	113559	113559S	4" F	3" F	50	326TS	8.375"	18"	6.188"	12"	7"	4"	29.526"	29.775"	4"	9/16"	40.38"	47.38"	3.5"	10.67"
GU 3C 2 600-WE10	113560	113560S	4" F	3" F	60	364TS	9.375"	21"	6.188"	12"	7"	4"	29.526"	33.673"	4"	9/16"	46.08"	50.08"	2"	9.17"
GU 3C 2 750-WE10	113561	113561S	4" F	3" F	75	365TS	9.375"	21"	6.188"	12"	7"	4"	29.526"	33.673"	4"	9/16"	46.08"	50.08"	2"	9.17"
GU 3E 2 100-4-WE4	113562	113562S	4" F	3" F	10	215T	6.375"	15"	7.25"	11"	8.625"	3.875"	30.866"	19.431"	3"	9/16"	29.71"	36.71"	3.5"	12.33"
GU 3E 2 150-4-WE4	113563	113563S	4" F	3" F	15	254T	6.375"	15"	7.25"	11"	8.625"	3.875"	30.856"	24.647"	3"	9/16"	33.11"	42.11"	4.5"	13.33"
GU 3E 2 200-4-WE4	113564	113564S	4" F	3" F	20	256T	6.375"	15"	7.25"	11"	8.625"	3.875"	30.856"	24.647"	3"	9/16"	33.11"	42.11"	4.5"	13.33"
GU 3E 2 250-4-WE10	113565	113565S	4" F	3" F	25	284T	7.375"	16"	7.25"	11"	8.625"	3.875"	31.106"	28.083"	3"	9/16"	39.61"	45.61"	3"	11.83"
GU 3F 2 150-4-WE5	113566	113566S	4" F	3" F	15	254T	6.375"	15"	7.25"	11"	8.625"	3.875"	30.856"	24.647"	3"	9/16"	33.11"	42.11"	4.5"	13.33"
GU 3F 2 200-4-WE5	113567	113567S	4" F	3" F	20	256T	6.375"	15"	7.25"	11"	8.625"	3.875"	30.856"	24.647"	3"	9/16"	33.11"	42.11"	2"	10.83"
GU 3F 2 250-4-WE10	113568	113568S	4" F	3" F	25	284T	7.375"	16"	7.25"	11"	8.625"	3.875"	31.106"	28.083"	3"	9/16"	39.61"	45.61"	3"	11.83"
GU 3F 2 300-4-WE10	113569	113569S	4" F	3" F	30	286T	7.375"	16"	7.25"	11"	8.625"	3.875"	31.106"	28.083"	3"	9/16"	39.61"	45.61"	3"	11.83"
GU 3G 3 250-4-WE10	113625	113625S	4" F	3" F	25	284T	8.375"	18"	8"	14.25"	9.75"	3.75"	35.877"	28.088"	4"	9/16"	44.18"	48.18"	2"	12.62"
GU 3G 3 300-4-WE10	113626	113626S	4" F	3" F	30	286T	8.375"	18"	8"	14.25"	9.75"	3.75"	35.877"	28.088"	4"	9/16"	44.18"	48.18"	2"	12.62"
GU 3G 3 400-4-WE20	113627	113627S	4" F	3" F	40	324T	9.375"	20"	8"	14.25"	9.75"	3.75"	36.322"	31.72"	4"	9/16"	48.28"	52.28"	2"	12.62"
GU 3G 3 500-4-WE20	113628	113628S	4" F	3" F	50	326T	9.375"	20"	8"	14.25"	9.75"	3.75"	36.322"	31.72"	4"	9/16"	48.28"	52.28"	2"	12.62"
GU 4B 1 30-4-WE3	113570	113570S	5" F	4" F	3	182T	5.375"	12"	6.25"	9.25"	7.25"	4.375"	24.274"	16.02"	3"	9/16"	24.81"	28.81"	2"	9.62"
GU 4B 1 50-4-WE3	113571	113571S	5" F	4" F	5	184T	5.375"	12"	6.25"	9.25"	7.25"	4.375"	24.274"	16.02"	3"	9/16"	24.81"	28.81"	2"	9.62"
GU 4B 1 75-4-WE3	113572	113572S	5" F	4" F	7.5	213T	6.375"	14"	6.25"	9.25"	7.25"	4.375"	24.274"	19.431"	3"	9/16"	28.51"	32.51"	2"	9.62"
GU 4B 2 250-WE5	113573	113573S	5" F	4" F	25	284TS	6.375"	15"	6.25"	11"	7.25"	4.375"	30.807"	26.711"	3"	9/16"	35.21"	44.21"	4.5"	13.03"
GU 4B 2 300-WE5	113574	113574S	5" F	4" F	30	286TS	6.375"	15"	6.25"	11"	7.25"	4.375"	30.807"	26.711"	3"	9/16"	35.21"	44.21"	4.5"	13.03"
GU 4B 2 400-WE10	113575	113575S	5" F	4" F	40	324TS	8.375"	18"	6.25"	12"	7.25"	4.375"	30.812"	29.775"	4"	9/16"	40.38"	47.38"	3.5"	11.96"
GU 4B 2 500-WE10	113576	113576S	5" F	4" F	50	326TS	8.375"	18"	6.25"	12"	7.25"	4.375"	30.812"	29.775"	4"	9/16"	40.38"	47.38"	3.5"	11.96"
GU 4C 1 75-4-WE4	113577	113577S	5" F	4" F	7.5	213T	6.375"	14"	7.051"	10.25"	7.5"	4.25"	24.747"	19.421"	4"	9/16"	28.48"	32.48"	2"	10.03"
GU 4C 1 100-4-WE4	113578	113578S	5" F	4" F	10	215T	6.375"	14"	7.051"	10.25"	7.5"	4.25"	24.747"	19.421"	4"	9/16"	28.48"	32.48"	2"	10.03"
GU 4C 1 150-4-WE5	113579	113579S	5" F	4" F	15	254T	6.375"	15"	7.051"	10.25"	7.5"	4.25"	24.997"	24.897"	4"	9/16"	34.48"	38.48"	2"	10.03"
GU 4C 1 200-4-WE5	113580	113580S	5" F	4" F	20	256T	6.375"	15"	7.051"	10.25"	7.5"	4.25"	24.997"	24.897"	4"	9/16"	34.48"	38.48"	2"	10.03"
GU 4C 2 500-WE10	113581	113581S	5" F	4" F	50	326TS	8.375"	18"	7.051"	12"	7.5"	4.25"	31.299"	29.775"	4"	9/16"	40.38"	47.38"	3.5"	12.44"
GU 4C 2 600-WE10	113582	113582S	5" F	4" F	60	364TS	9.375"	21"	7.051"	12"	7.5"	4.25"	31.299"	33.673"	4"	9/16"	46.08"	50.08"	2"	10.94"
GU 4C 2 750-WE10	113583	113583S	5" F	4" F	75	365TS	9.375"	21"	7.051"	12"	7.5"	4.25"	31.299"	33.673"	4"	9/16"	46.08"	50.08"	2"	10.94"
GU 4C 2 1000-WE20	113584	113584S	5" F	4" F	100	405TS	10.375"	22"	7.051"	14"	7.5"	4.25"	31.744"	38.082"	6"	9/16"	51.66"	55.66"	2"	10.63"
GU 4C 2 1250-WE20	113585	113585S	5" F	4" F	125	444TS	12.375"	27"	7.051"	14"	7.5"	4.25"	31.744"	42.793"	6"	9/16"	56.36"	60.36"	2"	10.63"
GU 4E 2 150-4-WE5	113586	113586S	5" F	4" F	15	254T	6.375"	15"	8.375"	11"	10"	5.25"	32.335"	24.647"	3"	9/16"	38.11"	42.11"	2"	12.3"
GU 4E 2 200-4-WE5	113587	113587S	5" F	4" F	20	256T	6.375"	15"	8.375"	11"	10"	5.25"	32.335"	24.647"	3"	9/16"	38.11"	42.11"	2"	12.3"
GU 4E 2 250-4-WE10	113588	113588S	5" F	4" F	25	284T	7.375"	16"	8.375"	11"	10"	5.25"	32.585"	28.083"	3"	9/16"	36.61"	45.61"	4.5"	14.8"
GU 4E 2 300-4-WE10	113589	113589S	5" F	4" F	30	286T	7.375"	16"	8.375"	11"	10"	5.25"	32.585"	28.083"	3"	9/16"	36.61"	45.61"	4.5"	14.8"
GU 4E 2 400-4-WE20	113590	113590S	5" F	4" F	40	324T	8.375"	18"	8.375"	12"	10"	5.25"	33.035"	31.72"	4"	9/16"	45.78"	49.78"	2"	12.23"
GU 4E 2 500-4-WE20	113591	113591S	5" F	4" F	50	326T	8.375"	18"	8.375"	12"	10"	5.25"	33.035"	31.72"	4"	9/16"	45.78"	49.78"	2"	12.23"
GU 4G 3 400-4-WE20	113592	113592S	5" F	4" F	40	324T	9.375"	20"	8.948"	14.25"	11"	4.375"	37.08"	31.72"	4"	9/16"	48.28"	52.28"	2"	13.38"
GU 4G 3 500-4-WE20	113593	113593S	5" F	4" F	50	326T	9.375"	20"	8.948"	14.25"	11"	4.375"	37.08"	31.72"	4"	9/16"	48.28"	52.28"	2"	13.38"
GU 4G 3 600-4-WE30	113594	113594S	5" F	4" F	60	364TS	9.375"	20"	8.948"	14.25"	11"	4.375"	37.245"	34.2625"	4"	9/16"	47.68"	53.68"	3"	14.38"
GU 4G 3 750-4-WE30	113595	113595S	5" F	4" F	75	365TS	9.375"	20"	8.948"	14.25"	11"	4.375"	37.245"	34.2625"	4"	9/16"	47.68"	53.68"	3"	14.38"
GU 5C 2 100-4-WE4	113596	113596S	6" F	5" F	10	215T	6.375"	15"	7.625"	11"	8"	5.25"	32.624"	19.431"	3"	9/16"	29.71"	36.71"	3.5"	14.08"
GU 5C 2 150-4-WE5	113597	113597S	6" F	5" F	15	254T	6.375"	15"	7.625"	11"	8"	5.25"	32.614"	24.647"	3"	9/16"	38.11"	42.11"	2"	12.58"
GU 5C 2 200-4-WE5	113598	113598S	6" F	5" F	20	256T	6.375"	15"	7.625"	11"	8"	5.25"	32.614"	24.647"	3"	9/16"	38.11"	42.11"	2"	12.58"
GU 5C 2 250-4-WE10	113599	113599S	6" F	5" F	25	284T	7.375"	16"	7.625"	11"	8"	5.25"	32.864"	28.083"	3"	9/16"	36.61"	45.61"	4.5"	15.08"

F = Flanged / NPT = Threaded

Technical specifications are subject to change without prior notice.

Dimensions (in)																				
MODEL	Ref. Cast Iron Imp.	Ref. Stainless Steel Imp.	Succ	Desc	Power (HP)	Frame	HE	HA	Z	HD	X	Y	CP	C MAX"	HG	HH	HF	HB	HP	HL
GU 5C 2 300-4-WE10	113600	113600S	6" F	5" F	30	286T	7.375"	16"	7.625"	11"	8"	5.25"	32.864"	28.083"	3"	9/16"	36.61"	45.61"	4.5"	15.08"
GU 5E 2 200-4-WE5	113601	113601S	6" F	5" F	20	256T	6.375"	15"	83.125"	11"	10.5"	5.5"	33.381"	24.647"	3"	9/16"	38.11"	42.11"	2"	13.35"
GU 5E 2 250-4-WE10	113602	113602S	6" F	5" F	25	284T	7.375"	16"	83.125"	11"	10.5"	5.5"	33.631"	28.083"	3"	9/16"	36.61"	45.61"	4.5"	15.85"
GU 5E 2 300-4-WE10	113603	113603S	6" F	5" F	30	286T	7.375"	16"	83.125"	11"	10.5"	5.5"	33.631"	28.083"	3"	9/16"	36.61"	45.61"	4.5"	15.85"
GU 5E 2 400-4-WE20	113604	113604S	6" F	5" F	40	324T	8.375"	18"	83.125"	12"	10.5"	5.5"	34.081"	31.72"	4"	9/16"	45.78"	49.78"	2"	13.28"
GU 5E 2 500-4-WE20	113605	113605S	6" F	5" F	50	326T	8.375"	18"	83.125"	12"	10.5"	5.5"	34.081"	31.72"	4"	9/16"	42.78"	49.78"	3.5"	14.78"
GU 5G 4 250-4-WE20	113629	113629S	6" F	5" F	25	284T	8.375"	18"	9.875"	15"	10"	5.75"	39.176"	28533"	4"	9/16"	46.78"	50.78"	2"	14.57"
GU 5G 4 300-4-WE20	113630	113630S	6" F	5" F	30	286T	8.375"	18"	9.875"	15"	10"	5.75"	39.176"	28533"	4"	9/16"	46.78"	50.78"	2"	14.57"
GU 5G 4 400-4-WE20	113631	113631S	6" F	5" F	40	324T	9.375"	20"	9.875"	15"	10"	5.75"	39.176"	31.72"	4"	9/16"	49.98"	53.98"	2"	14.57"
GU 5G 4 500-4-WE20	113632	113632S	6" F	5" F	50	326T	9.375"	20"	9.875"	15"	10"	5.75"	39.176"	31.72"	4"	9/16"	49.98"	53.98"	2"	14.57"
GU 5G 4 600-4-WE30	113633	113633S	6" F	5" F	60	364TS	9.375"	21"	9.875"	15"	10"	5.75"	393.205"	342.625"	4"	9/16"	51.48"	55.48"	2"	14.57"
GU 5G 4 750-4-WE30	113634	113634S	6" F	5" F	75	365TS	9.375"	21"	9.875"	15"	10"	5.75"	393.205"	342.625"	4"	9/16"	51.48"	55.48"	2"	14.57"
GU 5G 4 1000-4-WE40	113635	113635S	6" F	5" F	100	405TS	10.375"	22"	9.875"	15"	10"	5.75"	39.406"	38.312"	4"	9/16"	51.08"	60.08"	4.5"	17.07"
GU 6C 2 150-4-WE5	113606	113606S	8" F	6" F	15	254T	7.375"	17"	8.56"	14"	8.375"	6.125"	33.873"	24.647"	6"	9/16"	38.18"	42.18"	2"	13.63"
GU 6C 2 200-4-WE5	113607	113607S	8" F	6" F	20	256T	7.375"	17"	8.56"	14"	8.375"	6.125"	33.873"	24.647"	6"	9/16"	38.18"	42.18"	2"	13.63"
GU 6C 2 250-4-WE10	113608	113608S	8" F	6" F	25	284T	7.375"	17"	8.56"	14"	8.375"	6.125"	34.128"	28.088"	6"	9/16"	41.68"	45.68"	2"	13.63"
GU 6C 2 300-4-WE10	113609	113609S	8" F	6" F	30	286T	7.375"	17"	8.56"	14"	8.375"	6.125"	34.128"	28.088"	6"	9/16"	41.68"	45.68"	2"	13.63"
GU 6C 2 400-4-WE20	113610	113610S	8" F	6" F	40	324T	8.375"	18"	8.56"	14"	8.375"	6.125"	34.573"	31.72"	6"	9/16"	45.06"	50.06"	2.5"	14.13"
GU 6E 2 250-4-WE10	113611	113611S	8" F	6" F	25	284T	7.375"	16"	9.688"	14"	8.875"	6.125"	34.198"	28.088"	6"	9/16"	41.96"	45.96"	2"	13.7"
GU 6E 2 300-4-WE10	113612	113612S	8" F	6" F	30	286T	7.375"	16"	9.688"	14"	8.875"	6.125"	34.198"	28.088"	6"	9/16"	41.96"	45.96"	2"	13.7"
GU 6E 2 400-4-WE20	113613	113613S	8" F	6" F	40	324T	8.375"	18"	9.688"	14"	8.875"	6.125"	34.643"	31.72"	6"	9/16"	45.06"	50.06"	2.5"	14.2"
GU 6E 2 500-4-WE20	113614	113614S	8" F	6" F	50	326T	8.375"	18"	9.688"	14"	8.875"	6.125"	34.643"	31.72"	6"	9/16"	45.06"	50.06"	2.5"	14.2"
GU 6E 2 600-4-WE30	113615	113615S	8" F	6" F	60	364TS	9.375"	21"	9.688"	14"	8.875"	6.125"	347.875"	342.625"	6"	9/16"	42.46"	51.46"	4.5"	16.06"
GU 6E 2 750-4-WE30	113616	113616S	8" F	6" F	75	365TS	9.375"	21"	9.688"	14"	8.875"	6.125"	347.875"	342.625"	6"	9/16"	42.46"	51.46"	4.5"	16.06"
GU 6G 4 1000-4-WE40	113617	113617S	8" F	6" F	100	405TS	10.375"	22"	11.062"	15"	10"	6.125"	40.554"	38.312"	4"	9/16"	51.08"	60.08"	4.5"	18.22"
GU 6G 4 1250-4-WE40	113618	113618S	8" F	6" F	125	444TS	11.375"	24"	11.062"	15"	10"	6.125"	40.554"	44.023"	4"	9/16"	61.28"	65.28"	2"	15.72"
GU 6G 4 1500-4-WE40	113619	113619S	8" F	6" F	150	445TS	11.375"	24"	11.062"	15"	10"	6.125"	40.554"	44.023"	4"	9/16"	61.28"	65.28"	2"	15.72"
GU 6G 4 2000-4-WE60	113620	113620S	8" F	6" F	200	445TS	11.375"	24"	11.062"	15"	10"	6.125"	41.074"	43.543"	4"	9/16"	61.78"	65.78"	2"	15.72"
GU 8E 3 600-4-WE30	113621	113621S	10" F	8" F	60	364TS	9.375"	20"	7.875"	14.25"	13"	7"	397.255"	342.625"	4"	9/16"	43.68"	53.68"	5"	18.88"
GU 8E 3 750-4-WE30	113622	113622S	10" F	8" F	75	365TS	9.375"	20"	7.875"	14.25"	13"	7"	397.255"	342.625"	4"	9/16"	43.68"	53.68"	5"	18.88"
GU 8E 3 1000-4-WE40	113623	113623S	10" F	8" F	100	405TS	10.375"	22"	7.875"	16.25"	13"	7"	39.811"	38.312"	6"	9/16"	54.66"	58.66"	2"	15.59"
GU 8E 3 1250-4-WE40	113624	113624S	10" F	8" F	125	444TS	12.375"	27"	7.875"	16.25"	13"	7"	39.811"	43.023"	6"	9/16"	59.36"	63.36"	2"	15.59"

F = Flanged / NPT = Threaded

Technical specifications are subject to change without prior notice.

Pump Features						
Pump Type	Design				Impeller	
End suction	Close Coupled / Frame Mounted				Enclosed / Cast Iron / SS	
Stages	Mechanical Seal				Fluid temperature range	
1	1 1/4" T1				158° F (70° C)	
MODEL	Ref. Cast Iron Impeller	Ref. SS Impeller	Ø Suction	Ø Discharge	Ø Impeller	
1 GE 1B 20	1B0205	1B0205S	1 1/4" NPT	1" NPT	4.250"	
2 GE 1B 30	1B0206	1B0206S	1 1/4" NPT	1" NPT	4.900"	
3 GE 1B 50	1B0207	1B0207S	1 1/4" NPT	1" NPT	6.000"	
4 GE 1B 75	1B0208	1B0208S	1 1/4" NPT	1" NPT	6.500"	
5 GE 1B 100	1B0209	1B0209S	1 1/4" NPT	1" NPT	7.100"	
5 GU 1B 1	1B0185	1B0185S	1 1/4" NPT	1" NPT	7.100"	

Motor Features			
Drive		Speed (rpm)	Frequency (Hz)
Electric		3600 (nominal)	60
Power (HP)	Phase	Voltage (V)	Frame
2	3	230/460	145JM
3	3	230/460	145JM
5	3	230/460	184JM
7.5	3	230/460	184JM
10	3	230/460	215JM
Frame Mounted			

Performance Curve

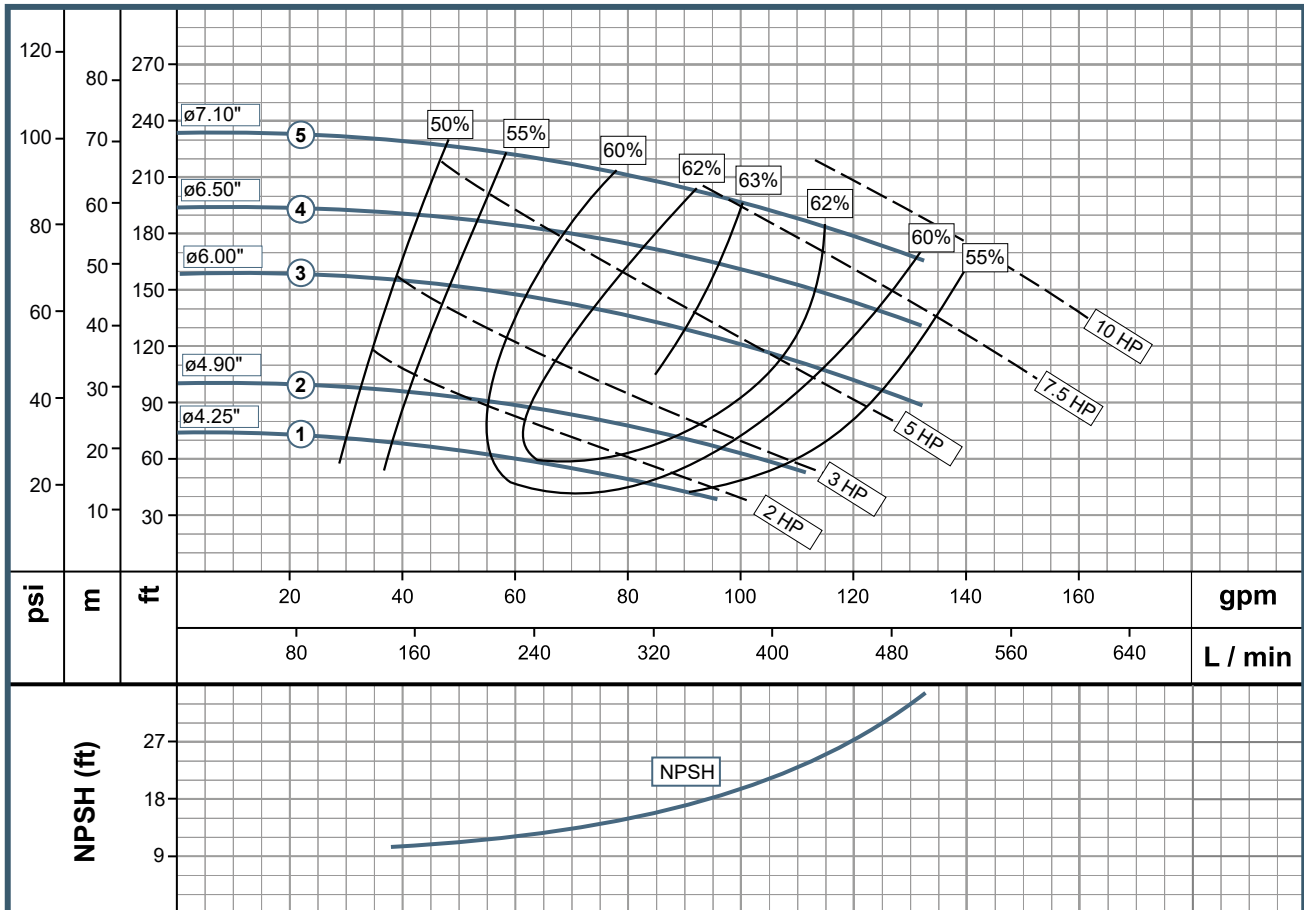

TEFC Enclosure as standard configuration.
 SS= Stainless Steel.
 Technical specifications are subject to change without prior notice.

GS Line

- GE 1.25A 7
- GE 1.25A 10
- GE 1.25A 15
- GE 1.25A 20
- GE 1.25A 30



www.wdmpumps.com

Pump Features						
Pump Type	Design			Impeller		
End Suction	Close Coupled			Enclosed / Cast Iron / SS		
Stages	Mechanical Seal			Fluid temperature range		
1	5/8" T6			158° F (70° C)		
MODEL	Ref. Cast Iron Impeller	Ref. SS Impeller	Ø Suction	Ø Discharge	Ø Impeller	
1	GE 1.25A 7	1B0210	1B0210S	1 1/2" NPT	1 1/4" NPT	3.250"
2	GE 1.25A 10	1B0211	1B0211S	1 1/2" NPT	1 1/4" NPT	3.750"
3	GE 1.25A 15	1B0212	1B0212S	1 1/2" NPT	1 1/4" NPT	4.250"
4	GE 1.25A 20	1B0213	1B0213S	1 1/2" NPT	1 1/4" NPT	4.750"
5	GE 1.25A 30	1B0214	1B0214S	1 1/2" NPT	1 1/4" NPT	5.130"

Motor Features			
Drive		Speed (rpm)	Frequency (Hz)
Electric		3600 (nominal)	60
Power (HP)	Phase	Voltage (V)	Frame
0.7	3	230/460	56J
1	3	230/460	56J
1.5	3	230/460	56J
2	3	230/460	56J
3	3	230/460	56J

Performance Curve

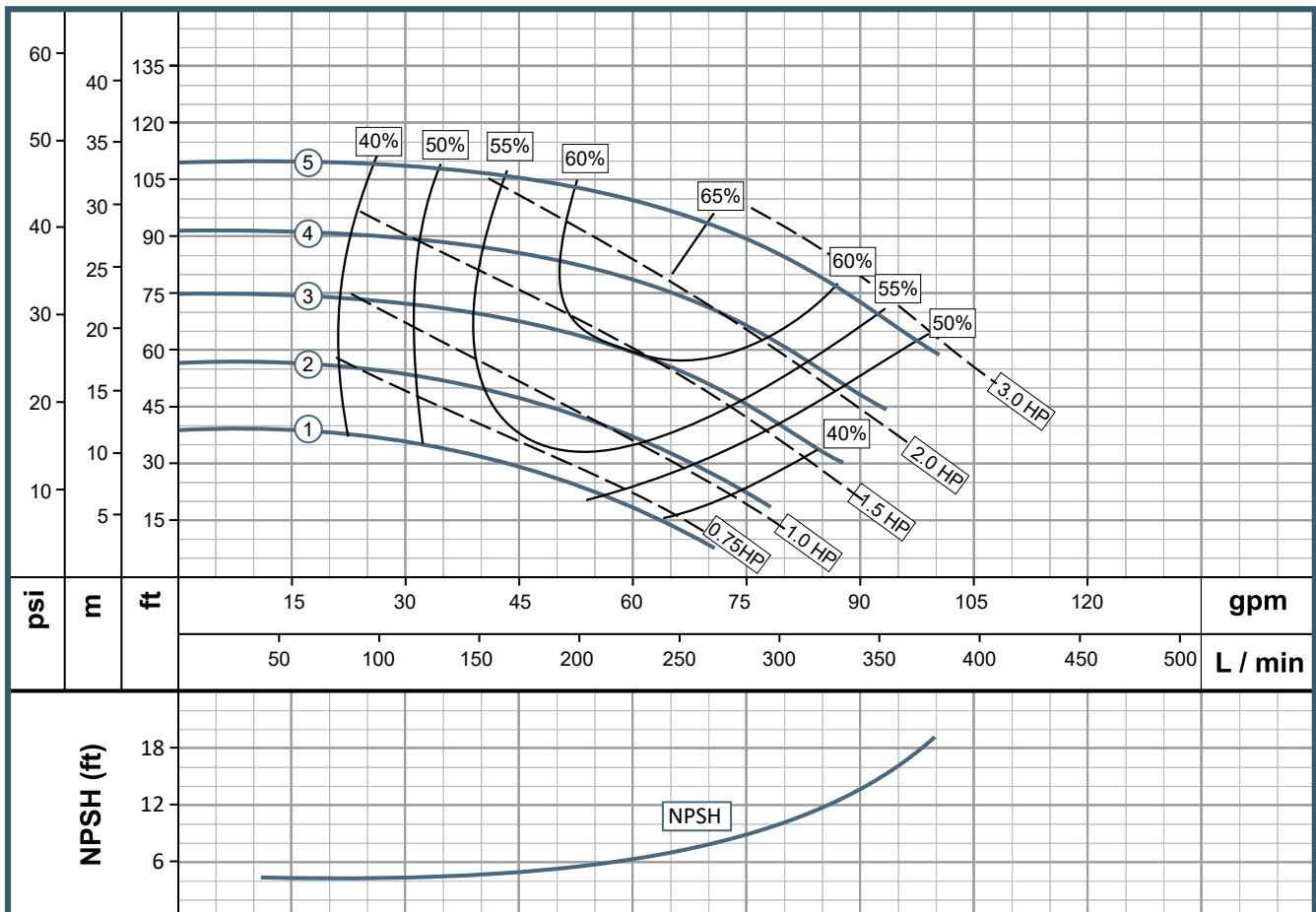

TEFC Enclosure as standard configuration.
SS= Stainless Steel.

Technical specifications are subject to change without prior notice.

Pump Features						
Pump Type	Design			Impeller		
End Suction	Close Coupled / Frame Mounted			Enclosed / Cast Iron / SS		
Stages	Mechanical Seal			Fluid temperature range		
1	1 1/4" T1			158° F (70° C)		
MODEL	Ref. Cast Iron Impeller	Ref. SS Impeller	Ø Suction	Ø Discharge	Ø Impeller	
1	GE 1.25B 50	1B0215	1B0215S	1 1/2" NPT	1 1/4" NPT 5.000"	
2	GE 1.25B 75	1B0216	1B0216S	1 1/2" NPT	1 1/4" NPT 5.750"	
3	GE 1.25B 100	1B0217	1B0217S	1 1/2" NPT	1 1/4" NPT 6.500"	
4	GE 1.25B 150	1B0218	1B0218S	1 1/2" NPT	1 1/4" NPT 7.100"	
4	GU 1.25B 1	1B0186	1B0186S	1 1/2" NPT	1 1/4" NPT 7.100"	

Motor Features			
Drive		Speed (rpm)	Frequency (Hz)
Electric		3600 (nominal)	60
Power (HP)	Phase	Voltage (V)	Frame
5	3	230/460	184JM
7.5	3	230/460	184JM
10	3	230/460	215JM
15	3	230/460	215JM
Frame Mounted			

Performance Curve

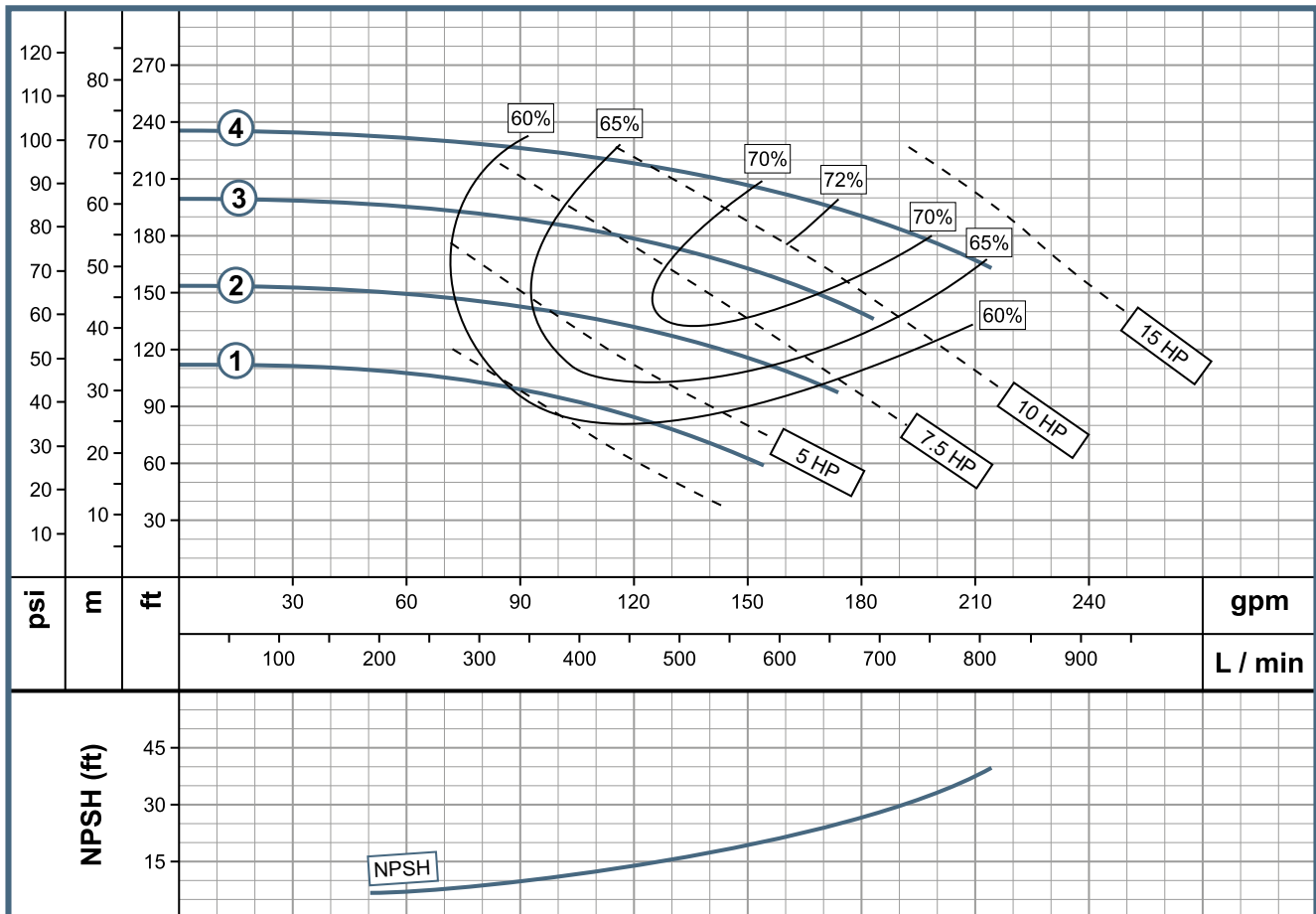

TEFC Enclosure as standard configuration.
 SS= Stainless Steel.

Technical specifications are subject to change without prior notice.

GS Line

- GE 1.5A 20
- GE 1.5A 30
- GE 1.5A 50
- GE 1.5A 75



www.wdmpumps.com

Pump Features					
Pump Type		Design		Impeller	
End Suction		Close Coupled		Enclosed / Cast Iron / SS	
Stages		Mechanical Seal		Fluid temperature range	
1		1 1/4" T1		158° F (70° C)	
MODEL	Reference	Ø Suction	Ø Discharge	Ø Impeller	
1	GE 1.5A 20	1B0450S	2" NPT	1 1/2" NPT 3.380"	
2	GE 1.5A 30	1B0451S	2" NPT	1 1/2" NPT 4.000"	
3	GE 1.5A 50	1B0452S	2" NPT	1 1/2" NPT 4.750"	
4	GE 1.5A 75	1B0453S	2" NPT	1 1/2" NPT 5.000"	

Motor Features			
Drive		Speed (rpm)	Frequency (Hz)
Electric		3600 (nominal)	60
Power (HP)	Phase	Voltage (V)	Frame
2	3	230/460	145JM
3	3	230/460	145JM
5	3	230/460	184JM
7.5	3	230/460	184JM

Performance Curve

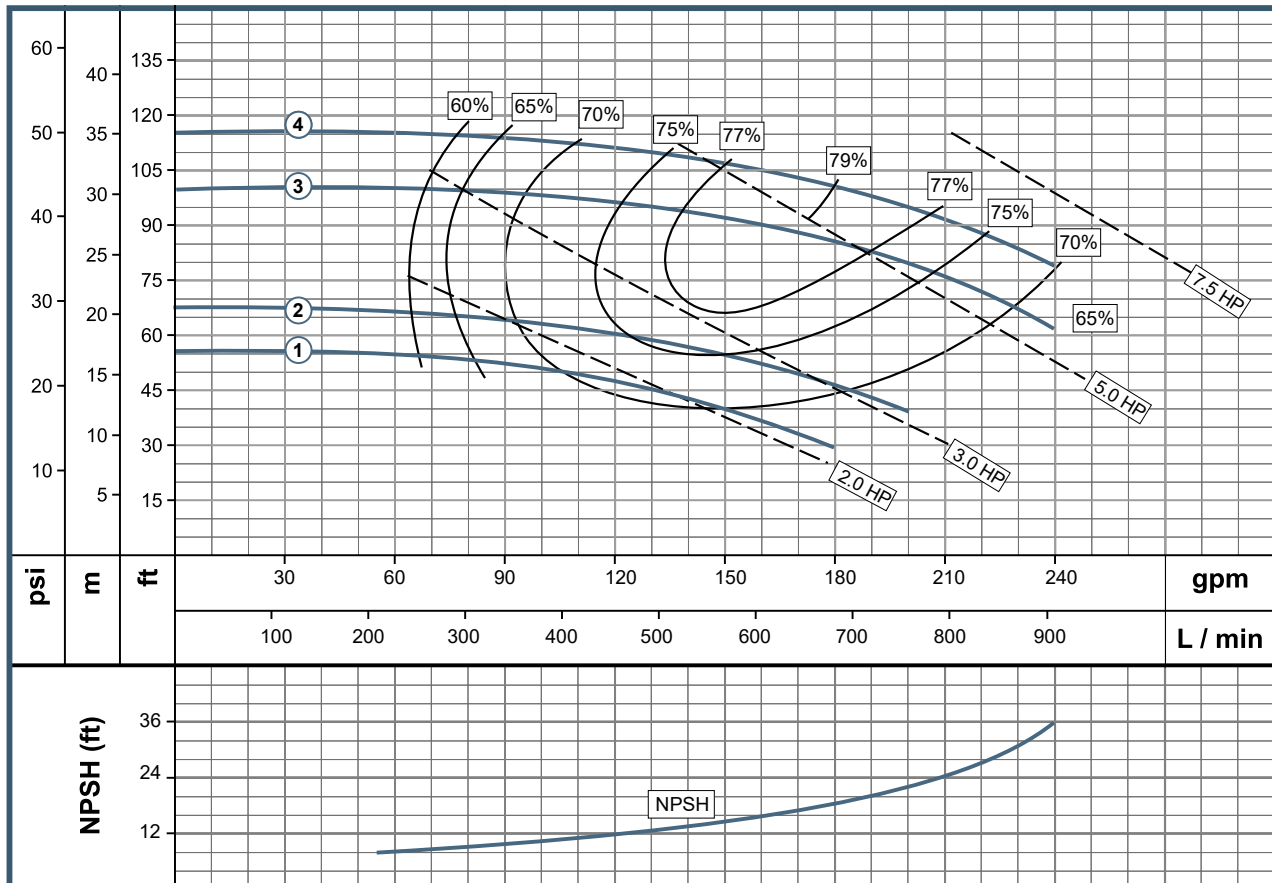

TEFC Enclosure as standard configuration.
SS= Stainless Steel.

Technical specifications are subject to change without prior notice.

Pump Features						
Pump Type	Design			Impeller		
End Suction	Close Coupled / Frame Mounted			Enclosed / Cast Iron / SS		
Stages	Mechanical Seal			Fluid temperature range		
1	1 1/4" T1			158° F (70° C)		
MODEL	Ref. Cast Iron Impeller	Ref. SS Impeller	Ø Suction	Ø Discharge	Ø Impeller	
1 GE 1.5B 50	1B0454	1B0454S	2" NPT	1 1/2" NPT	5.000"	
2 GE 1.5B 75	1B0455P	1B0455PS	2" NPT	1 1/2" NPT	5.870"	
3 GE 1.5B 100	1B0456	1B0456S	2" NPT	1 1/2" NPT	6.370"	
4 GE 1.5B 150	1B0457	1B0457S	2" NPT	1 1/2" NPT	7.100"	
4 GU 1.5B 1	1B0187	1B0187S	2" NPT	1 1/2" NPT	7.100"	

Motor Features			
Drive		Speed (rpm)	Frequency (Hz)
Electric		3600 (nominal)	60
Power (HP)	Phase	Voltage (V)	Frame
5	3	230/460	184JM
7.5	3	230/460	184JM
10	3	230/460	215JM
15	3	230/460	215JM
Frame Mounted			

Performance Curve

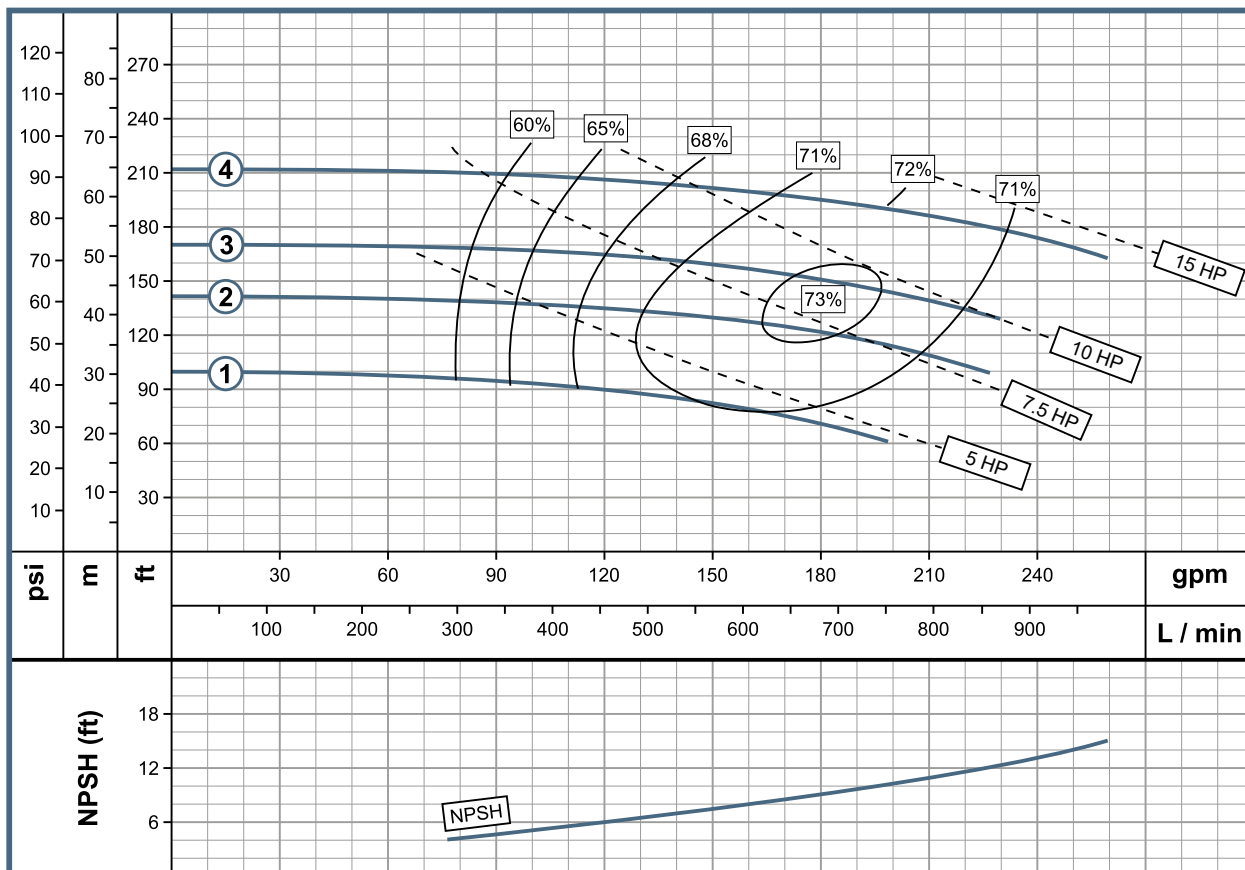

TEFC Enclosure as standard configuration.
 SS= Stainless Steel.

Technical specifications are subject to change without prior notice.

GS Line

- GE 1.5C 100
- GE 1.5C 150
- GE 1.5C 200
- GE 1.5C 250
- GU 1.5C 2



www.wdmpumps.com

Pump Features						
Pump Type		Design			Impeller	
End Suction		Close Coupled / Frame Mounted			Enclosed / Cast Iron / SS	
Stages		Mechanical Seal			Fluid temperature range	
1		1 1/4" T21 (1,2) / 1 3/4" T21 (3,4)			158° F (70° C)	
MODEL	Ref. Cast Iron Impeller	Ref. SS Impeller	Ø Suction	Ø Discharge	Ø Impeller	
1 GE 1.5C 100	1B0001	1B0001S	2" NPT	1 1/2" NPT	7.500"	
2 GE 1.5C 150	1B0002	1B0002S	2" NPT	1 1/2" NPT	8.000"	
3 GE 1.5C 200	1B0003	1B0003S	2" NPT	1 1/2" NPT	9.000"	
4 GE 1.5C 250	1B0004	1B0004S	2" NPT	1 1/2" NPT	9.600"	
4 GU 1.5C 2	1B0101	1B0101S	2" NPT	1 1/2" NPT	9.600"	

Motor Features			
Drive		Speed (rpm)	Frequency (Hz)
Electric		3600 (nominal)	60
Power (HP)	Phase	Voltage (V)	Frame
10	3	230/460	215JM
15	3	230/460	215JM
20	3	230/460	254JM
25	3	230/460	256JM
Frame Mounted			

Performance Curve

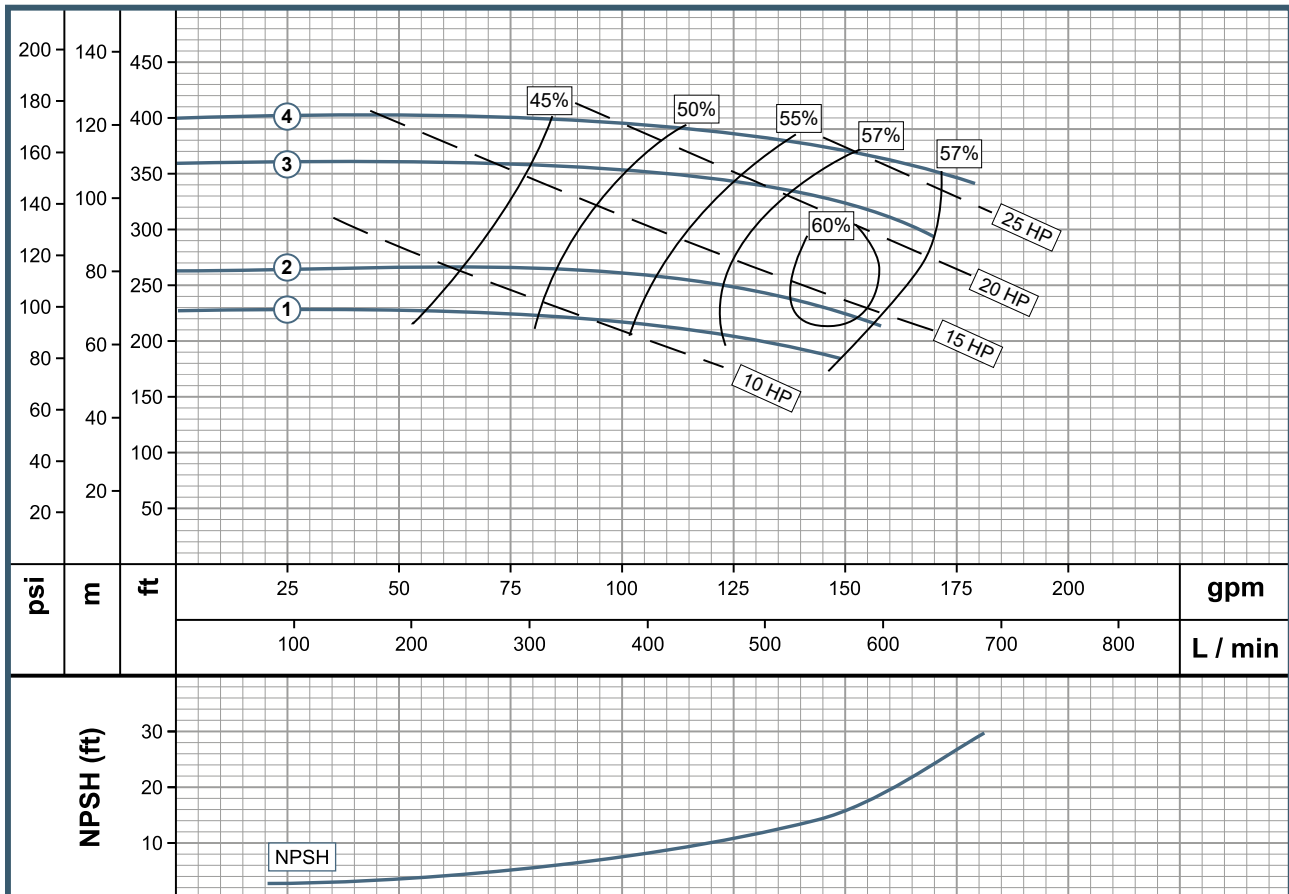

TEFC Enclosure as standard configuration.
SS= Stainless Steel.

Technical specifications are subject to change without prior notice.

Pump Features						
Pump Type	Design			Impeller		
End Suction	Close Coupled / Frame Mounted			Enclosed / Cast Iron / SS		
Stages	Mechanical Seal			Fluid temperature range		
1	1 3/4" T21			158° F (70° C)		
MODEL	Ref. Cast Iron Impeller	Ref. SS Impeller	Ø Suction	Ø Discharge	Ø Impeller	
1	GE 1.5D 200	1B0005	1B0005S	2" NPT	1 1/2" NPT	7.00"
2	GE 1.5D 250	1B0006	1B0006S	2" NPT	1 1/2" NPT	7.50"
3	GE 1.5D 300	1B0007	1B0007S	2" NPT	1 1/2" NPT	8.00"
4	GE 1.5D 400	1B0008	1B0008S	2" NPT	1 1/2" NPT	8.75"
5	GE 1.5D 500	1B0009	1B0009S	2" NPT	1 1/2" NPT	9.130"
6	GE 1.5D 600	1B0010	1B0010S	2" NPT	1 1/2" NPT	9.600"
6	GU 1.5D 2	1B0103	1B0103S	2" NPT	1 1/2" NPT	9.600"

Motor Features			
Drive		Speed (rpm)	Frequency (Hz)
Electric		3600 (nominal)	60
Power (HP)	Phase	Voltage (V)	Frame
20	3	230/460	254JM
25	3	230/460	256JM
30	3	230/460	286JM
40	3	230/460	324JM
50	3	230/460	326JM
60	3	230/460	364JM
Frame Mounted			

Performance Curve

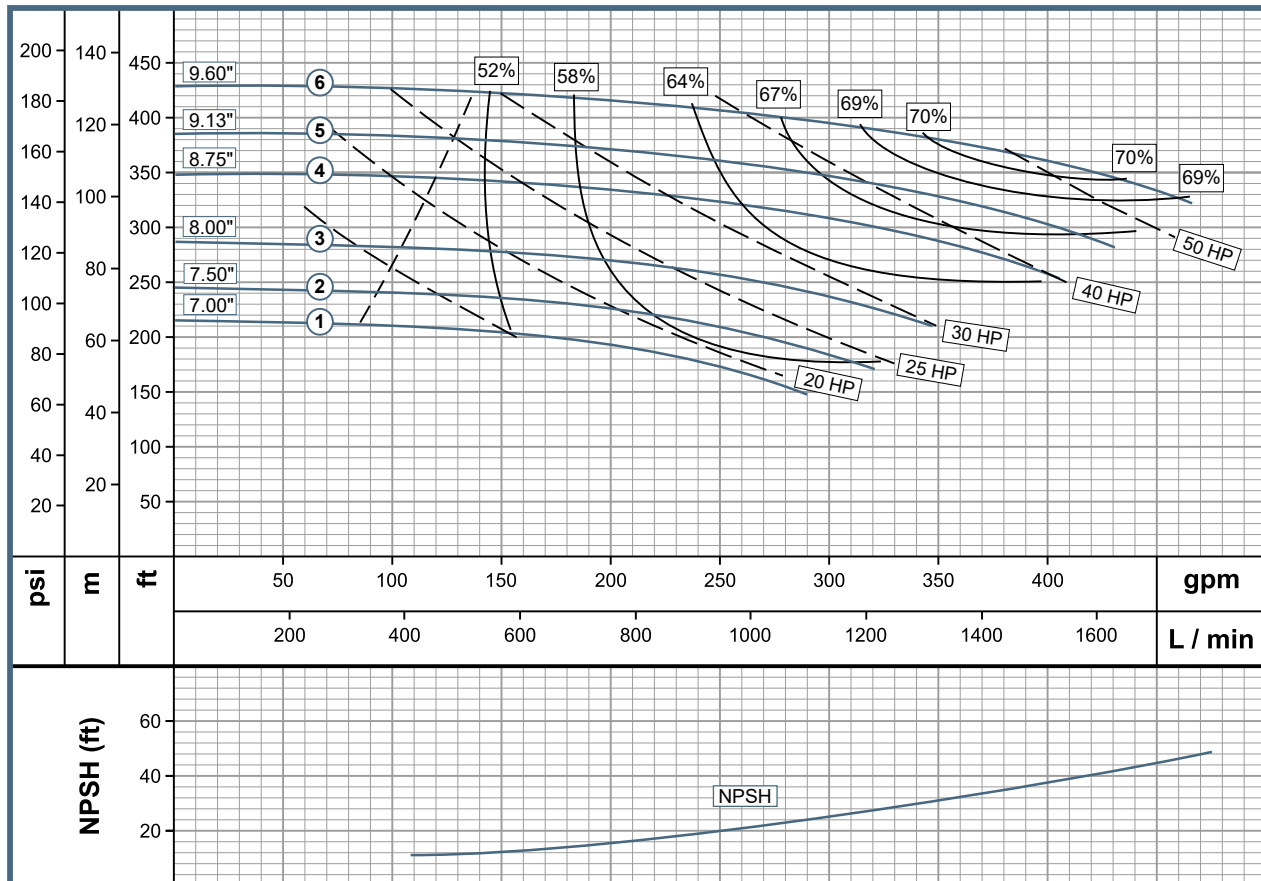

TEFC Enclosure as standard configuration.
 SS= Stainless Steel.
 Technical specifications are subject to change without prior notice.

GS Line

- GE 2B 75
- GE 2B 100
- GE 2B 150
- GE 2B 200
- GE 2B 250
- GU 2B 2



www.wdmpumps.com

Pump Features					
Pump Type	Design			Impeller	
End Suction	Close Coupled / Frame Mounted			Enclosed / Cast Iron / SS	
Stages	Mechanical Seal			Fluid temperature range	
1	1 1/4" T21 (1,2,3) / 1 3/4" T21 (4,5)			158° F (70° C)	
MODEL	Ref. Cast Iron Impeller	Ref. SS Impeller	Ø Suction	Ø Discharge	Ø Impeller
1 GE 2B 75	1B0011	1B0011S	2 1/2" NPT	2" NPT	5.000"
2 GE 2B 100	1B0012	1B0012S	2 1/2" NPT	2" NPT	5.500"
3 GE 2B 150	1B0013	1B0013S	2 1/2" NPT	2" NPT	6.000"
4 GE 2B 200	1B0014	1B0014S	2 1/2" NPT	2" NPT	6.500"
5 GE 2B 250	1B0015	1B0015S	2 1/2" NPT	2" NPT	7.100"
5 GU 2B 2	1B0105	1B0105S	2 1/2" NPT	2" NPT	7.100"

Motor Features			
Drive		Speed (rpm)	Frequency (Hz)
Electric		3600 (nominal)	60
Power (HP)	Phase	Voltage (V)	Frame
7,5	3	230/460	184JM
10	3	230/460	215JM
15	3	230/460	215JM
20	3	230/460	254JM
25	3	230/460	256JM
Frame Mounted			

Performance Curve

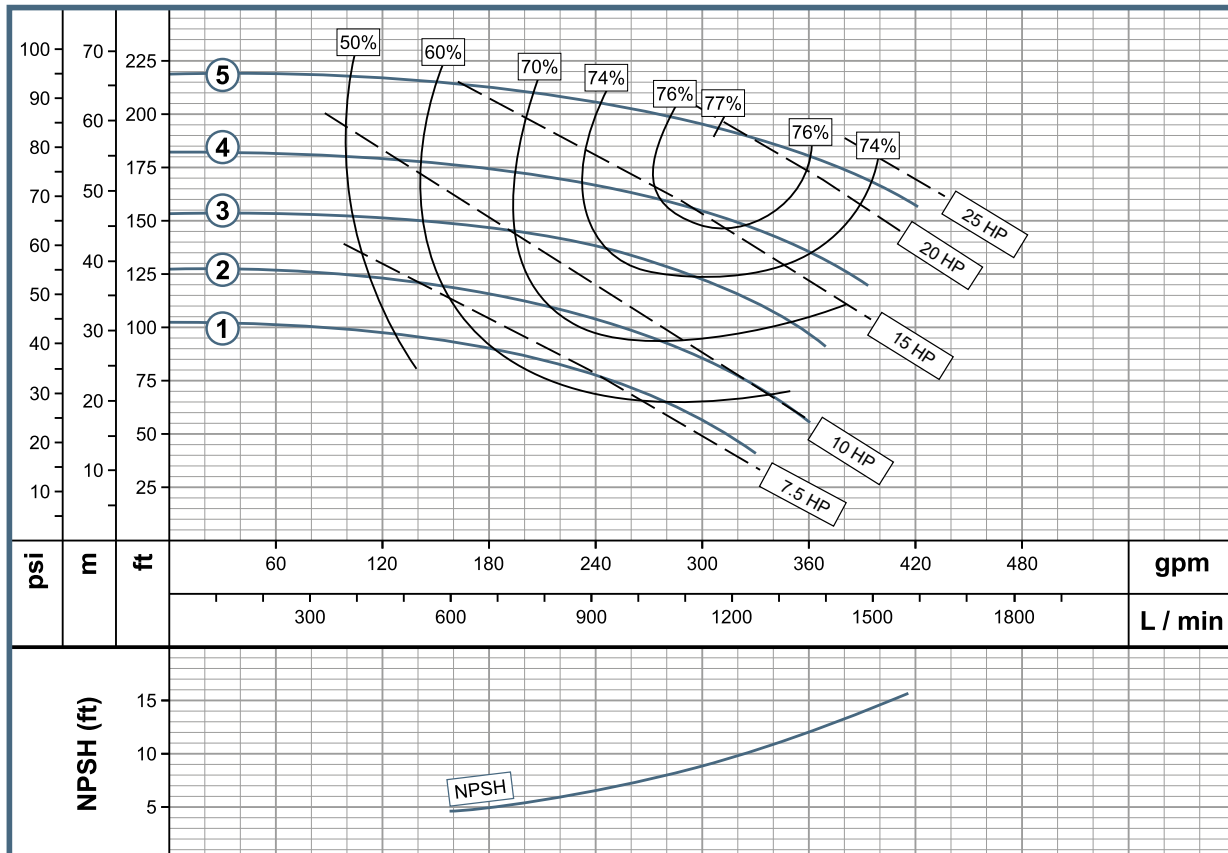

TEFC Enclosure as standard configuration.
 SS= Stainless Steel.
 Technical specifications are subject to change without prior notice.

Pump Features						
Pump Type	Design			Impeller		
End Suction	Close Coupled / Frame Mounted			Enclosed / Cast Iron / SS		
Stages	Mechanical Seal			Fluid temperature range		
1	1 3/4" T21			158° F (70° C)		
MODEL	Ref. Cast Iron Impeller	Ref. SS Impeller	Ø Suction	Ø Discharge	Ø Impeller	
1	GE 2C 200	1B0016	1B0016S	2 1/2" NPT	2" NPT	7.000"
2	GE 2C 250	1B0017	1B0017S	2 1/2" NPT	2" NPT	7.500"
3	GE 2C 300	1B0018	1B0018S	2 1/2" NPT	2" NPT	8.000"
4	GE 2C 400	1B0019	1B0019S	2 1/2" NPT	2" NPT	8.500"
5	GE 2C 500	1B0020	1B0020S	2 1/2" NPT	2" NPT	9.000"
6	GE 2C 600	1B0021	1B0021S	2 1/2" NPT	2" NPT	9.600"
6	GU 2C 2	1B0107	1B0107S	2 1/2" NPT	2" NPT	9.600"

Motor Features			
Drive		Speed (rpm)	Frequency (Hz)
Electric		3,600 (nominal)	60
Power (HP)	Phase	Voltage (V)	Frame
20	3	230/460	254JM
25	3	230/460	256JM
30	3	230/460	286JM
40	3	230/460	324JM
50	3	230/460	326JM
60	3	230/460	364JM
Frame Mounted			

Performance Curve

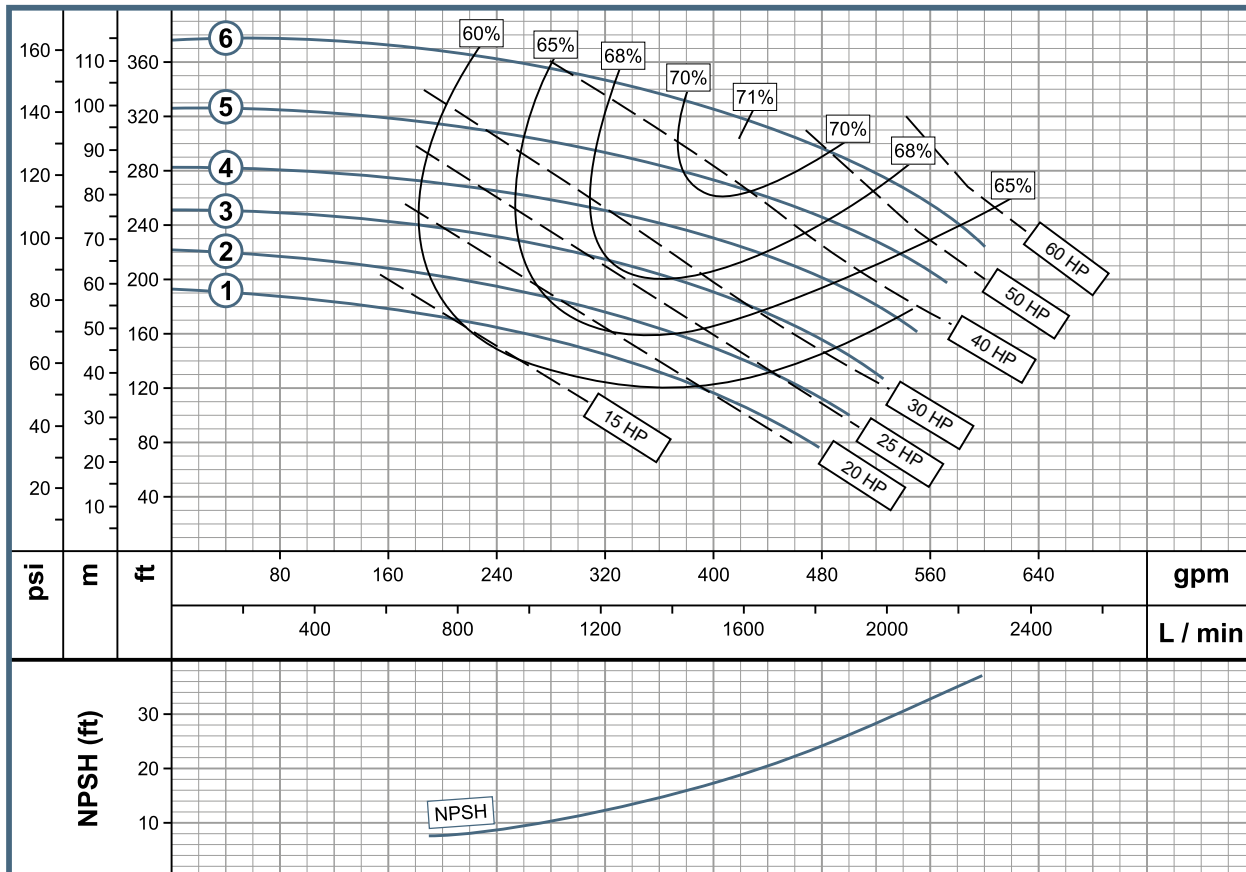

TEFC Enclosure as standard configuration.
 SS= Stainless Steel.

Technical specifications are subject to change without prior notice.

GS Line

- GE 2.5B 75
- GE 2.5B 100
- GE 2.5B 150
- GE 2.5B 200
- GE 2.5B 250
- GE 2.5B 300
- GU 2.5B 2



www.wdmpumps.com

Pump Features						
Pump Type	Design				Impeller	
End Suction	Close Coupled / Frame Mounted				Enclosed / Cast Iron / SS	
Stages	Mechanical Seal				Fluid temperature range	
1	1 1/4" T21 (1,2,3) / 1 3/4" T21 (4,5,6)				158° F (70° C)	
MODEL	Ref. Cast Iron Impeller	Ref. SS Impeller	Ø Suction	Ø Discharge	Ø Impeller	
1	GE 2.5B 75	1B0022	1B0022S	3" F	2 1/2" F	4.500"
2	GE 2.5B 100	1B0023	1B0023S	3" F	2 1/2" F	5.000"
3	GE 2.5B 150	1B0024	1B0024S	3" F	2 1/2" F	5.500"
4	GE 2.5B 200	1B0025	1B0025S	3" F	2 1/2" F	6.000"
5	GE 2.5B 250	1B0026	1B0026S	3" F	2 1/2" F	6.500"
6	GE 2.5B 300	1B0027	1B0027S	3" F	2 1/2" F	7.100"
6	GU 2.5B 2	1B0109	1B0109S	3" F	2 1/2" F	7.100"

Motor Features			
Drive		Speed (rpm)	Frequency (Hz)
Electric		3600 (nominal)	60
Power (HP)	Phase	Voltage (V)	Frame
7.5	3	230/460	184JM
10	3	230/460	215JM
15	3	230/460	215JM
20	3	230/460	254JM
25	3	230/460	256JM
30	3	230/460	286JM
Frame Mounted			

Performance Curve

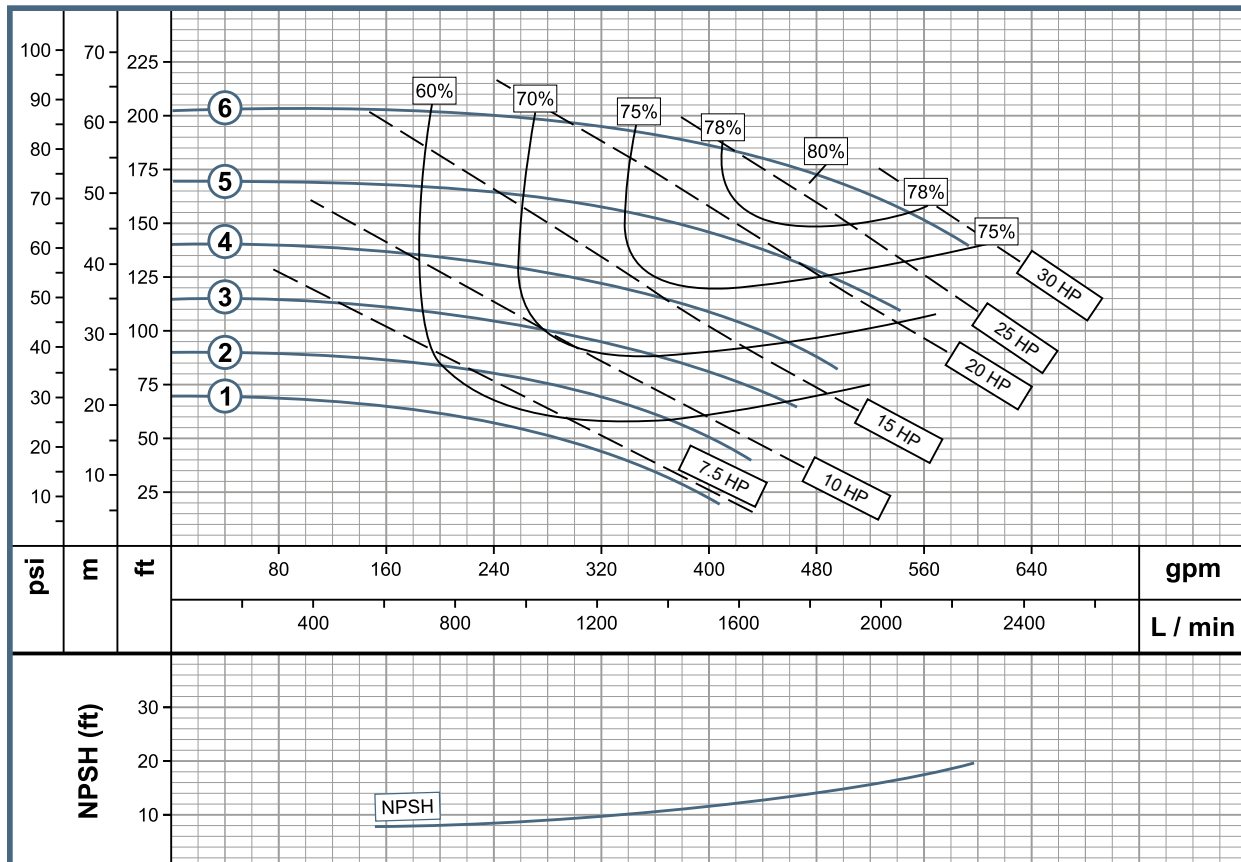

TEFC Enclosure as standard configuration.
SS= Stainless Steel.

Technical specifications are subject to change without prior notice.



GS Line

- GE 2.5C 200
- GE 2.5C 250
- GE 2.5C 300
- GE 2.5C 400
- GE 2.5C 500
- GE 2.5C 600
- GE 2.5C 750
- GU 2.5 C2

www.wdmpumps.com

Pump Features						
Pump Type	Design			Impeller		
End Suction	Close Coupled / Frame Mounted			Enclosed / Cast Iron / SS		
Stages	Mechanical Seal			Fluid temperature range		
1	1 3/4" T21			158° F (70° C)		
MODEL	Ref. Cast Iron Impeller	Ref. SS Impeller	Ø Suction	Ø Discharge	Ø Impeller	
1	GE 2.5C 200	1B0028	1B0028S	3" F	2 1/2" F	6.500"
2	GE 2.5C 250	1B0029	1B0029S	3" F	2 1/2" F	7.000"
3	GE 2.5C 300	1B0030	1B0030S	3" F	2 1/2" F	7.500"
4	GE 2.5C 400	1B0031	1B0031S	3" F	2 1/2" F	8.000"
5	GE 2.5C 500	1B0032	1B0032S	3" F	2 1/2" F	8.500"
6	GE 2.5C 600	1B0033	1B0033S	3" F	2 1/2" F	9.000"
7	GE 2.5C 750	1B0034	1B0034S	3" F	2 1/2" F	9.600"
7	GU 2.5 C2	1B0111	1B0111S	3" F	2 1/2" F	9.600"

Motor Features			
Drive		Speed (rpm)	Frequency (Hz)
Electric		3600 (nominal)	60
Power (HP)	Phase	Voltage (V)	Frame
20	3	230/460	254JM
25	3	230/460	256JM
30	3	230/460	286JM
40	3	230/460	324JM
50	3	230/460	326JM
60	3	230/460	364JM
75	3	230/460	365JM
Frame Mounted			

Performance Curve

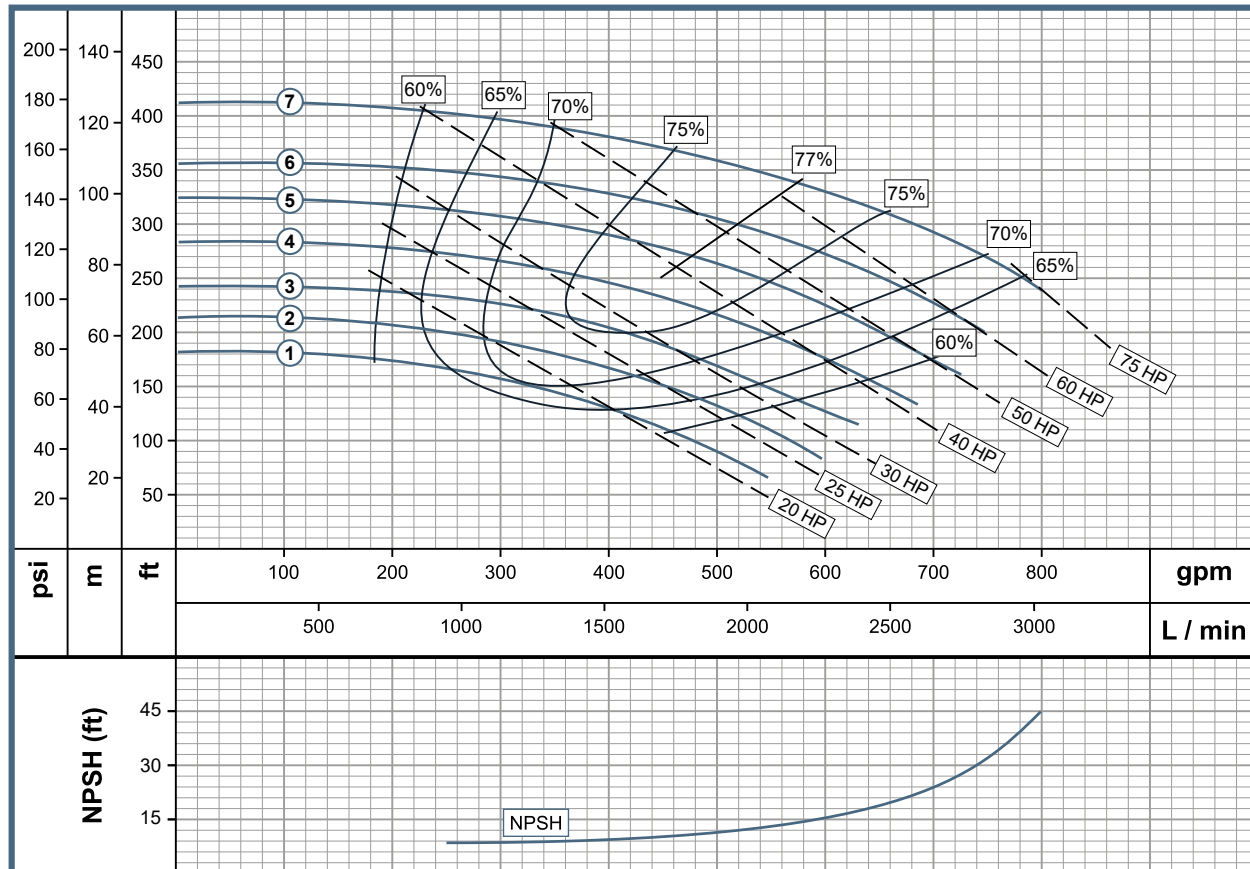

TEFC Enclosure as standard configuration.
SS= Stainless Steel.

Technical specifications are subject to change without prior notice.

GS Line

- GE 3B 100
- GE 3B 150
- GE 3B 200
- GE 3B 250
- GE 3B 300
- GE 3B 400
- GU 3B 2



www.wdmpumps.com

Pump Features						
Pump Type	Design			Impeller		
End Suction	Close Coupled / Frame Mounted			Enclosed / Cast Iron / SS		
Stages	Mechanical Seal			Fluid temperature range		
1	1 1/4" T21 (1,2) / 1 3/4" T21 (3,4,5,6)			158° F (70° C)		
MODEL	Ref. Cast Iron Impeller	Ref. SS Impeller	Ø Suction	Ø Discharge	Ø Impeller	
1 GE 3B 100	1B0035	1B0035S	4" F	3" F	4.500"	
2 GE 3B 150	1B0036	1B0036S	4" F	3" F	5.000"	
3 GE 3B 200	1B0037	1B0037S	4" F	3" F	5.500"	
4 GE 3B 250	1B0038	1B0038S	4" F	3" F	6.000"	
5 GE 3B 300	1B0039	1B0039S	4" F	3" F	6.500"	
6 GE 3B 400	1B0040	1B0040S	4" F	3" F	7.100"	
6 GU 3B 2	1B0113	1B0113S	4" F	3" F	7.100"	

Motor Features			
Drive		Speed (rpm)	Frequency (Hz)
Electric		3600 (nominal)	60
Power (HP)	Phase	Voltage (V)	Frame
10	3	230/460	215JM
15	3	230/460	215JM
20	3	230/460	254JM
25	3	230/460	256JM
30	3	230/460	286JM
40	3	230/460	324JM
Frame Mounted			

Performance Curve

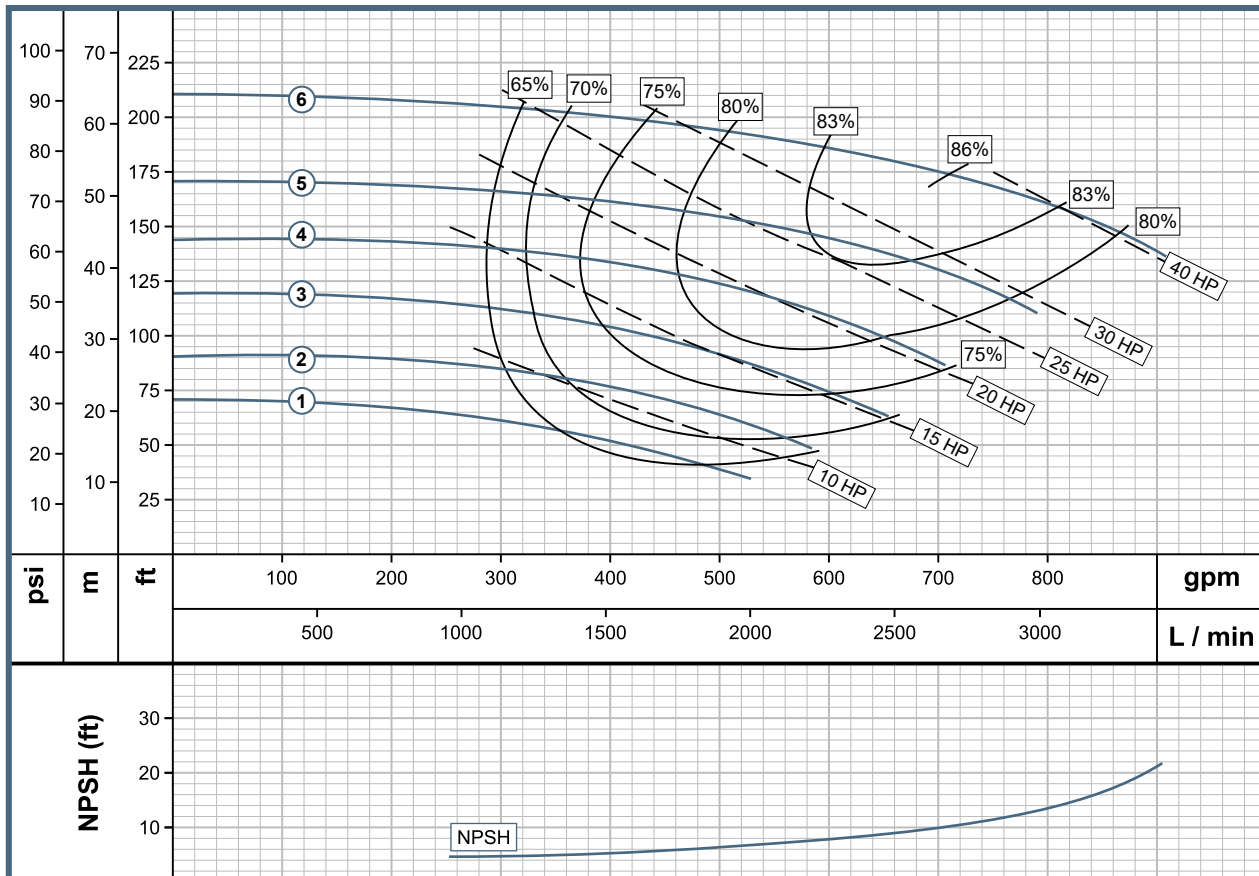

TEFC Enclosure as standard configuration.
SS= Stainless Steel.

Technical specifications are subject to change without prior notice.



GS Line

GE 3C 250
 GE 3C 300
 GE 3C 400
 GE 3C 500
 GE 3C 600
 GE 3C 750
 GU 3C 2

www.wdmpumps.com

Pump Features						
Pump Type	Design			Impeller		
End Suction	Close Coupled / Frame Mounted			Enclosed / Cast Iron / SS		
Stages	Mechanical Seal			Fluid temperature range		
1	1 3/4" T21			158° F (70° C)		
MODEL	Ref. Cast Iron Impeller	Ref. SS Impeller	Ø Suction	Ø Discharge	Ø Impeller	
1	GE 3C 250	1B0041	1B0041S	4" F	3" F	6.500"
2	GE 3C 300	1B0042	1B0042S	4" F	3" F	6.900"
3	GE 3C 400	1B0043	1B0043S	4" F	3" F	7.500"
4	GE 3C 500	1B0044	1B0044S	4" F	3" F	8.500"
5	GE 3C 600	1B0045	1B0045S	4" F	3" F	9.000"
6	GE 3C 750	1B0046	1B0046S	4" F	3" F	9.600"
6	GU 3C 2	1B0115	1B0115S	4" F	3" F	9.600"

Motor Features			
Drive		Speed (rpm)	Frequency (Hz)
Electric		3600 (nominal)	60
Power (HP)	Phase	Voltage (V)	Frame
25	3	230/460	256JM
30	3	230/460	286JM
40	3	230/460	324JM
50	3	230/460	326JM
60	3	230/460	364JM
75	3	230/460	365JM
Frame Mounted			

Performance Curve

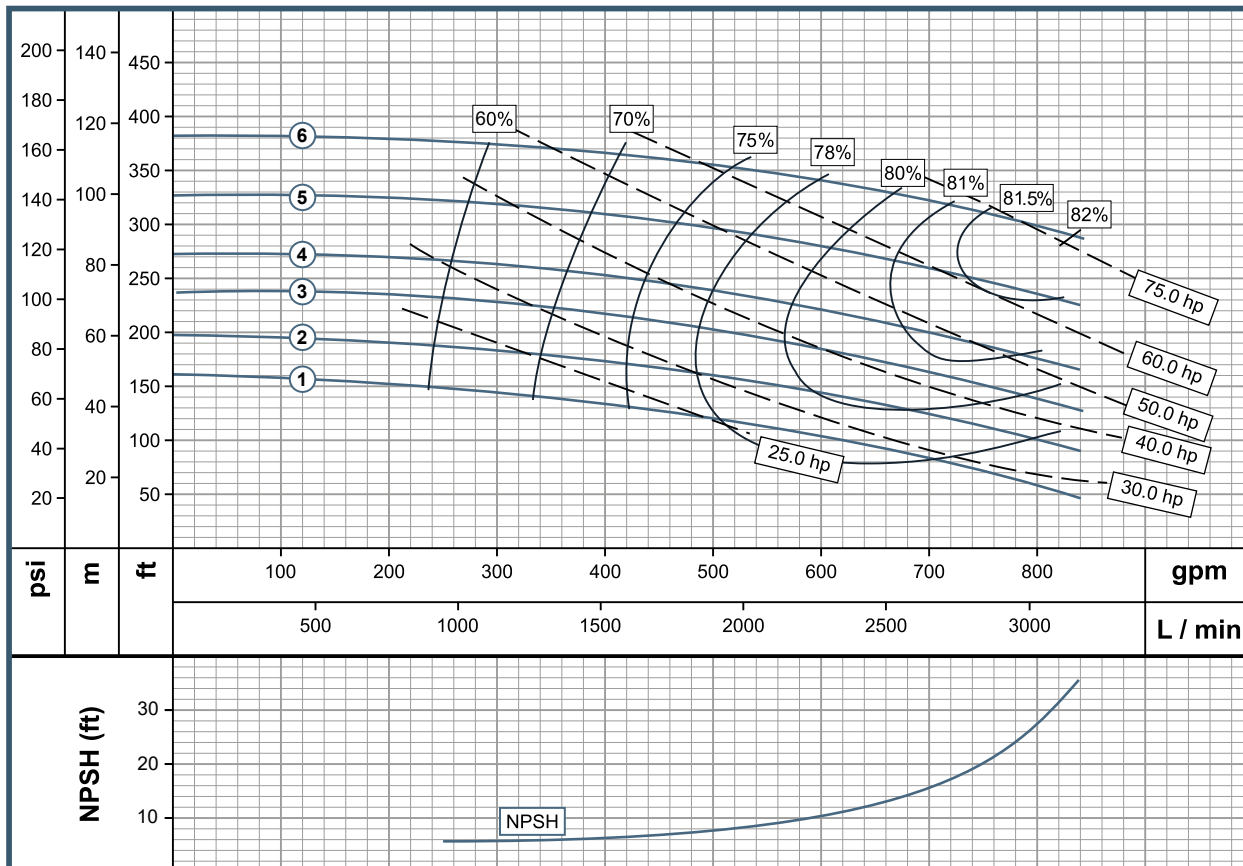

TEFC Enclosure as standard configuration.
 SS= Stainless Steel.

Technical specifications are subject to change without prior notice.

GS Line

GE 3H 750
GE 3H 1000
GE 3H 1250



www.wdmpumps.com

Pump Features						
Pump Type	Design			Impeller		
End Suction	Close Coupled			Enclosed / Cast Iron / SS		
Stages	Mechanical Seal			Fluid temperature range		
1	1 3/4" T21 (1) / 2" T21 (2)			158° F (70° C)		
MODEL	Ref. Cast Iron Impeller	Ref. SS Impeller	Ø Suction	Ø Discharge	Ø Impeller	
1	GE 3H 750	1B0144	1B0144S	5" F	3" F	9.000"
2	GE 3H 1000	1B0145	1B0145S	5" F	3" F	10.312"
3	GE 3H 1250	1B0146	1B0146S	5" F	3" F	10.437"

Motor Features			
Drive		Speed (rpm)	Frequency (Hz)
Electric		3600 (nominal)	60
Power (HP)	Phase	Voltage (V)	Frame
75	3	230/460	365JM
100	3	230/460	365JP ODP
125	3	230/460	444JP

Performance Curve

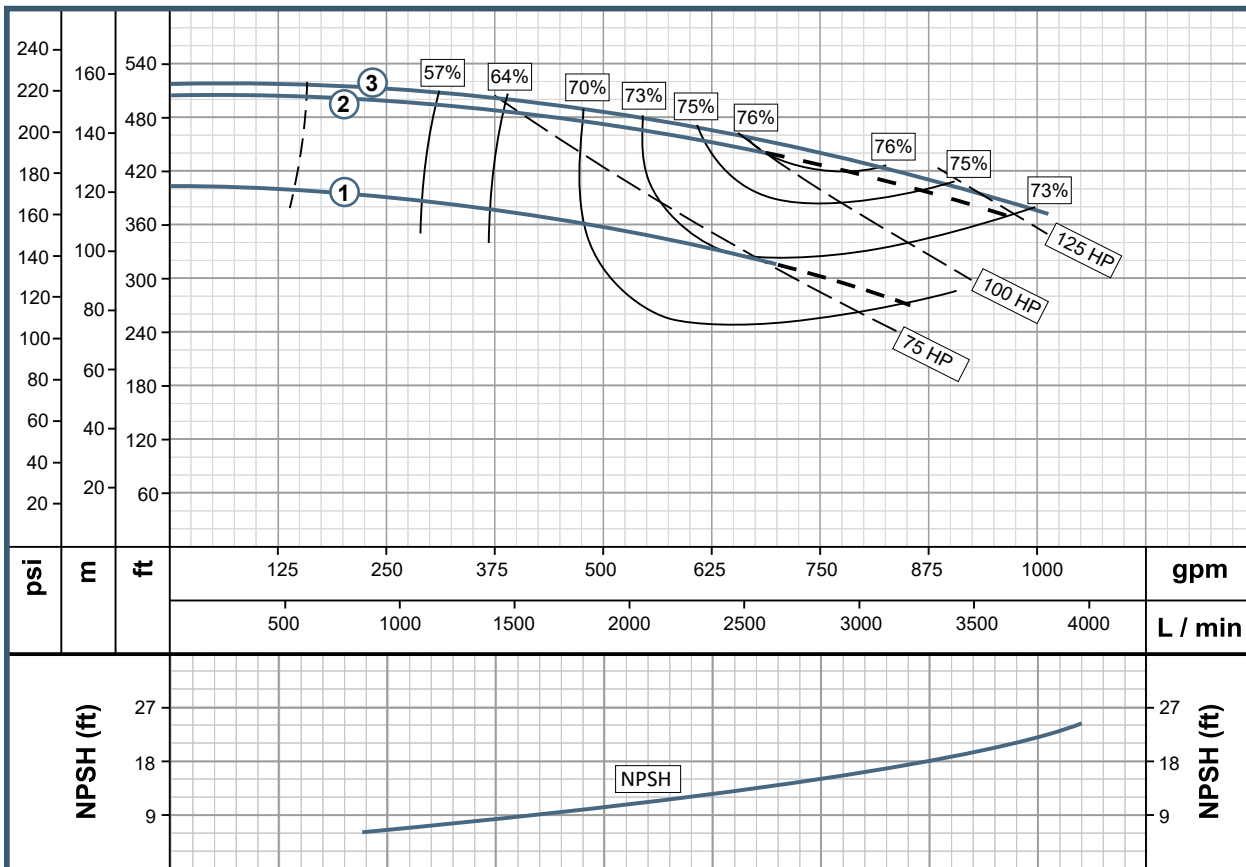

TEFC Enclosure as standard configuration.
SS= Stainless Steel.

Technical specifications are subject to change without prior notice.

Pump Features						
Pump Type		Design			Impeller	
End Suction	Close Coupled / Frame Mounted			Enclosed / Cast Iron / SS		
Stages	Mechanical Seal			Fluid temperature range		
1	1 3/4" T21			158° F (70° C)		
MODEL	Ref. Cast Iron Impeller	Ref. SS Impeller	Ø Suction	Ø Discharge	Ø Impeller	
1 GE 4B 250	1B0047	1B0047S	5" F	4" F	5.760"	
2 GE 4B 300	1B0048	1B0048S	5" F	4" F	6.100"	
3 GE 4B 400	1B0049	1B0049S	5" F	4" F	6.500"	
4 GE 4B 500	1B0050	1B0050S	5" F	4" F	7.100"	
4 GU 4B 2	1B0120	1B0120S	5" F	4" F	7.100"	

Motor Features			
Drive		Speed (rpm)	Frequency (Hz)
Electric		3600 (nominal)	60
Power (HP)	Phase	Voltage (V)	Frame
25	3	230/460	256JM
30	3	230/460	286JM
40	3	230/460	324JM
50	3	230/460	326JM
Frame Mounted			

Performance Curve

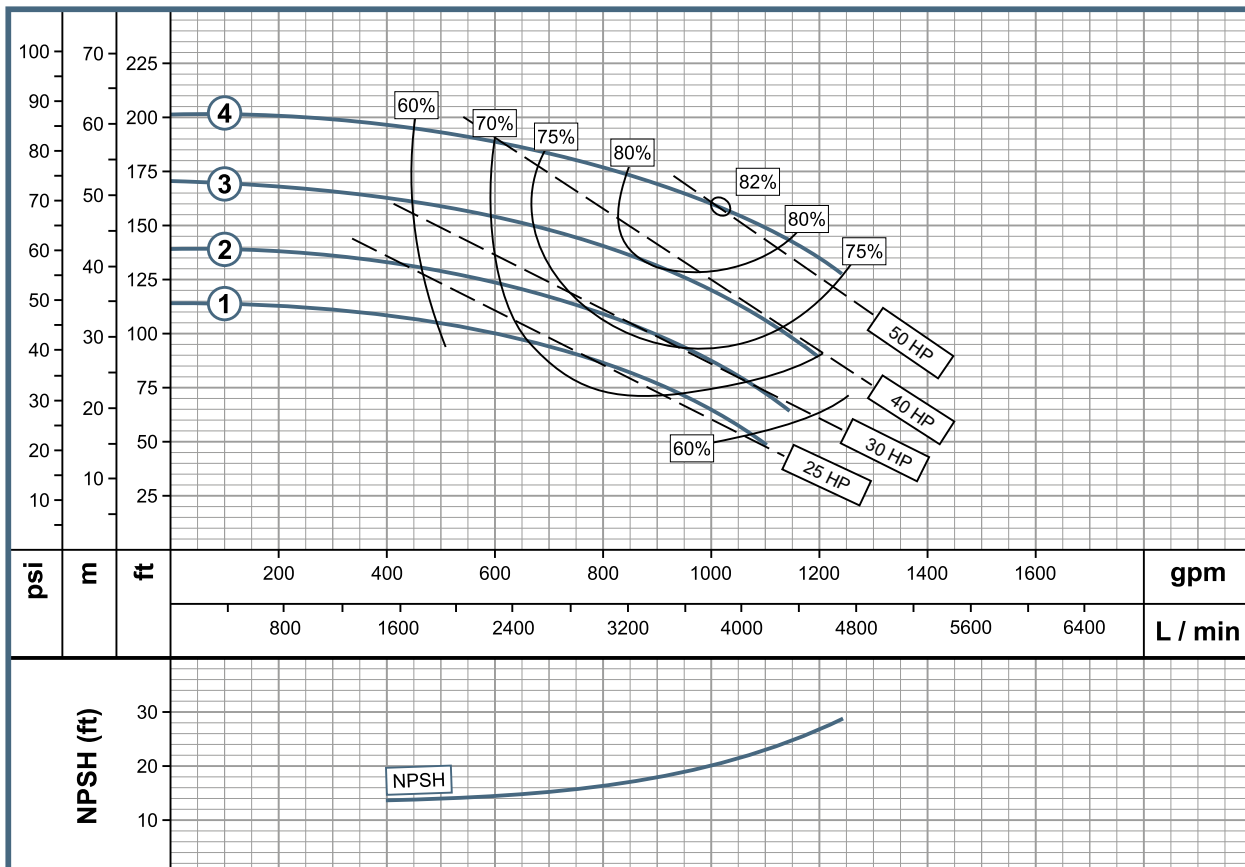

TEFC Enclosure as standard configuration.
 SS= Stainless Steel.

Technical specifications are subject to change without prior notice.

GS Line

- GE 4C 500
- GE 4C 600
- GE 4C 750
- GE 4C 1000
- GE 4C 1250
- GU 4C 2



www.wdmpumps.com

Pump Features						
Pump Type	Design			Impeller		
End Suction	Close Coupled / Frame Mounted			Enclosed / Cast Iron / SS		
Stages	Mechanical Seal			Fluid temperature range		
1	1 3/4" T21 (1,2,3) / 2" T21 (4,5)			158° F (70° C)		
MODEL	Ref. Cast Iron Impeller	Ref. SS Impeller	Ø Suction	Ø Discharge	Ø Impeller	
1	GE 4C 500	1B0051	1B0051S	5" F	4" F	7.000"
2	GE 4C 600	1B0137	1B0137S	5" F	4" F	7.500"
3	GE 4C 750	1B0052	1B0052S	5" F	4" F	8.000"
4	GE 4C 1000	1B0053	1B0053S	5" F	4" F	9.000"
5	GE 4C 1250	1B0054	1B0054S	5" F	4" F	9.300"
5	GU 4C 2	1B0117	1B0117S	5" F	4" F	9.300"

Motor Features			
Drive		Speed (rpm)	Frequency (Hz)
Electric		3600 (nominal)	60
Power (HP)	Phase	Voltage (V)	Frame
50	3	230/460	326JM
60	3	230/460	364JM
75	3	230/460	365JM
100	3	230/460	365JP
125	3	230/460	444JP
Frame Mounted			

Performance Curve

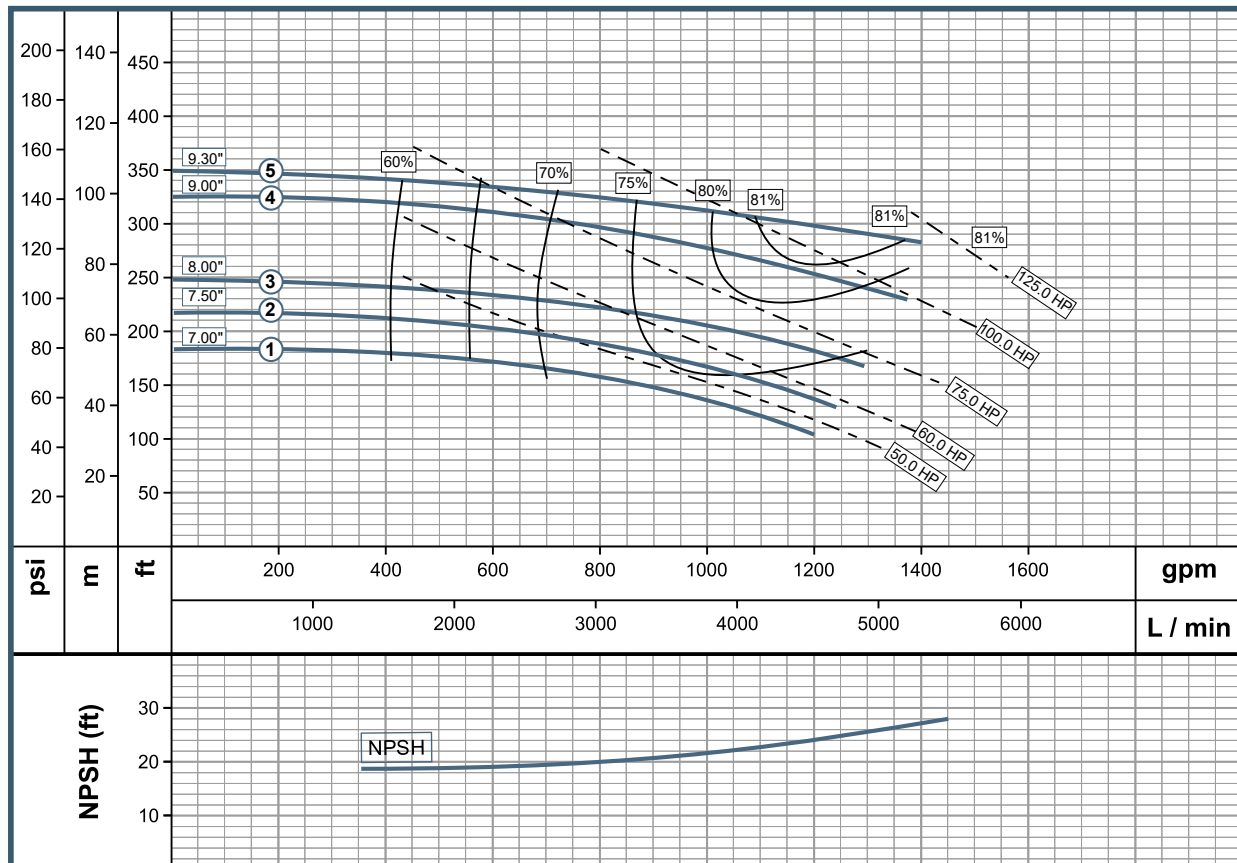

TEFC Enclosure as standard configuration.
SS= Stainless Steel.

Technical specifications are subject to change without prior notice.

Pump Features					
Pump Type	Design			Impeller	
End Suction	Close Coupled/ Frame Mounted			Enclosed / Cast Iron / SS	
Stages	Mechanical Seal			Fluid temperature range	
1	1 1/4" T1			158° F (70° C)	
MODEL	Ref. Cast Iron Impeller	Ref. SS Impeller	Ø Suction	Ø Discharge	Ø Impeller
1 GE 1B 10-4	1B0460	1B0460S	1 1/4" NPT	1" NPT	6.500"
2 GE 1B 15-4	1B0461	1B0461S	1 1/4" NPT	1" NPT	7.100"
2 GU 1B 1	1B0185	1B0185S	1 1/4" NPT	1" NPT	7.100"

Motor Features			
Drive		Speed (rpm)	Frequency (Hz)
Electric		1800 (nominal)	60
Power (HP)	Phase	Voltage (V)	Frame
1.0	3	230/460	143JM
1.5	3	230/460	145JM
Frame Mounted			

Performance Curve

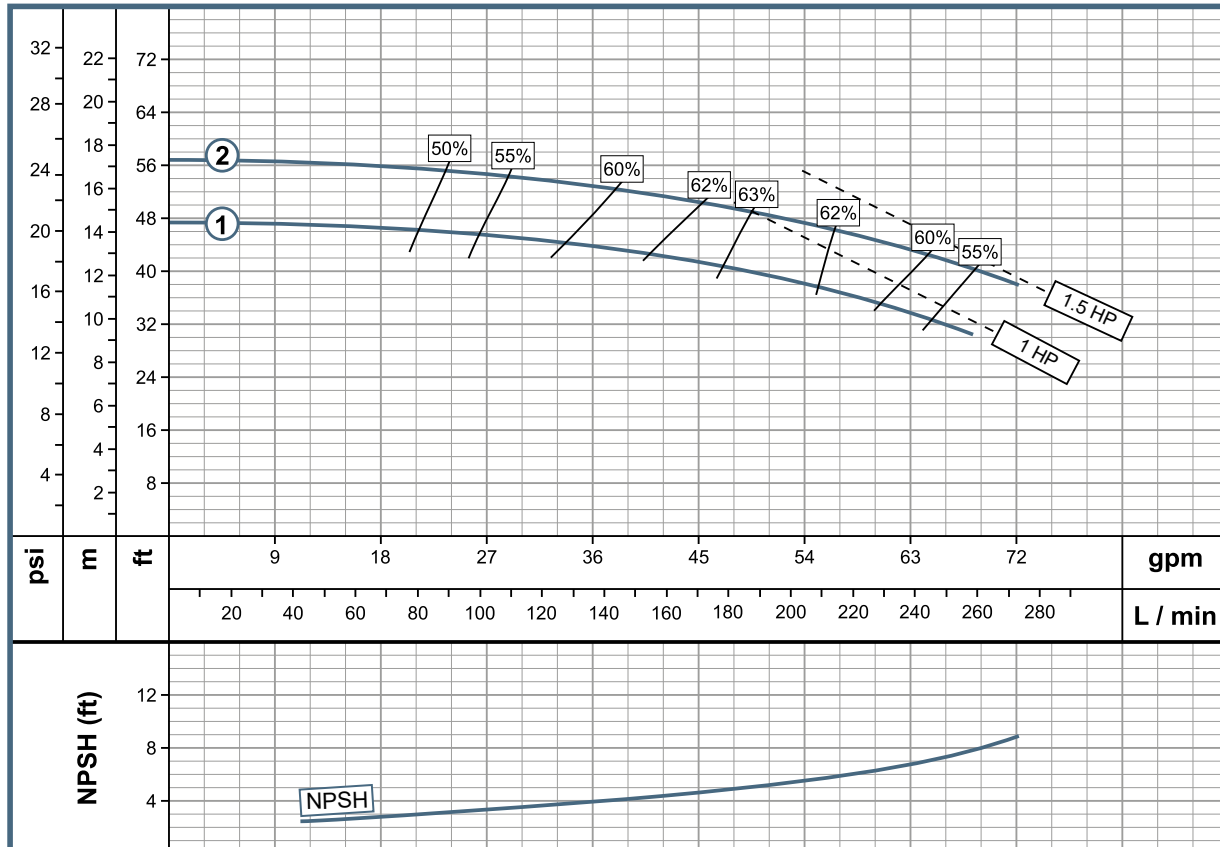

TEFC Enclosure as standard configuration.
SS= Stainless Steel.

Technical specifications are subject to change without prior notice.

GS Line

GE 1.25A 3-4
GE 1.25A 5-4



www.wdmpumps.com

Pump Features						
Pump Type	Design			Impeller		
End Suction	Close Coupled			Enclosed / Cast Iron / SS		
Stages	Mechanical Seal			Fluid temperature range		
1	5/8" T6			158° F (70° C)		
MODEL	Ref. Cast Iron Impeller	Ref. SS Impeller	Ø Suction	Ø Discharge	Ø Impeller	
1	GE 1.25A 3-4	1B0462	1B0462S	1 1/2" NPT	1 1/4" NPT	4.750
2	GE 1.25A 5-4	1B0463	1B0463S	1 1/2" NPT	1 1/4" NPT	5.130

Motor Features			
Drive		Speed (rpm)	Frequency (Hz)
Electric		1800 (nominal)	60
Power (HP)	Phase	Voltage (V)	Frame
0.3	3	230/460	56J
0.5	3	230/460	56J

Performance Curve

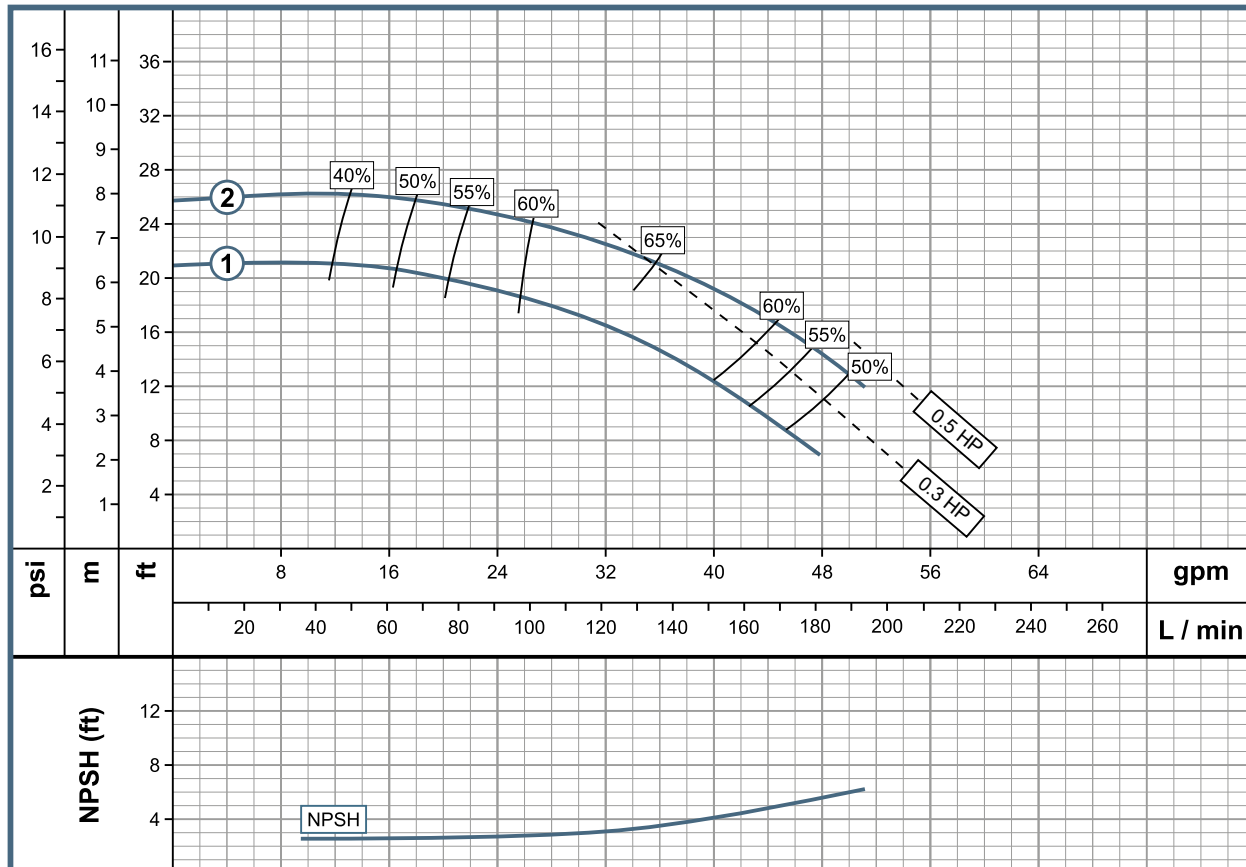

TEFC Enclosure as standard configuration.
SS= Stainless Steel.

Technical specifications are subject to change without prior notice.

Pump Features						
Pump Type	Design			Impeller		
End Suction	Close Coupled / Frame Mounted			Enclosed / Cast Iron / SS		
Stages	Mechanical Seal			Fluid temperature range		
1	1 1/4" T1			158° F (70° C)		
MODEL	Ref. Cast Iron Impeller	Ref. SS Impeller	Ø Suction	Ø Discharge	Ø Impeller	
1 GE 1.25B 10-4	1B0464	1B0464S	1 1/2" NPT	1 1/4" NPT	6.250"	
2 GE 1.25B 15-4	1B0465	1B0465S	1 1/2" NPT	1 1/4" NPT	6.750"	
3 GE 1.25B 20-4	1B0466	1B0466S	1 1/2" NPT	1 1/4" NPT	7.100"	
3 GU 1.25B 1	1B0186	1B0186S	1 1/2" NPT	1 1/4" NPT	7.100"	

Motor Features			
Drive		Speed (rpm)	Frequency (Hz)
Electric		1800 (nominal)	60
Power (HP)	Phase	Voltage (V)	Frame
1	3	230/460	143JM
1.5	3	230/460	145JM
2	3	230/460	145JM
Frame Mounted			

Performance Curve

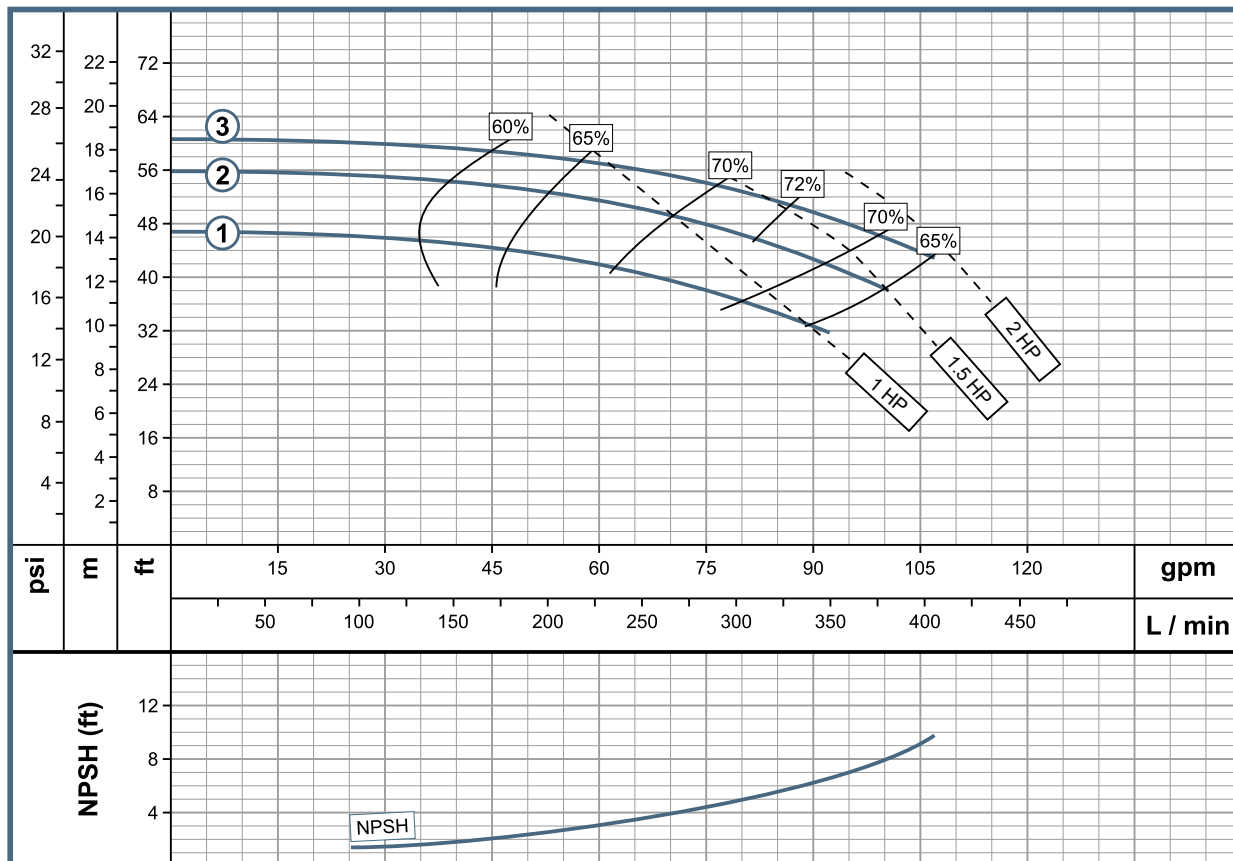

TEFC Enclosure as standard configuration.
 SS= Stainless Steel.

Technical specifications are subject to change without prior notice.

GS Line
GE 1.5A 10-4



www.wdmpumps.com

Pump Features				
Pump Type	Design		Impeller	
End Suction	Close Coupled		Enclosed / Cast Iron / SS	
Stages	Mechanical Seal		Fluid temperature range	
1	1 1/4" T1		158° F (70° C)	
MODEL	Reference	Ø Suction	Ø Discharge	Ø Impeller
GE 1.5A 10-4	1B0467S	2" NPT	1 1/2" NPT	5.000"

Motor Features			
Drive		Speed (rpm)	Frequency (Hz)
Electric		1800 (nominal)	60
Power (HP)	Phase	Voltage (V)	Frame
1	3	230/460	143JM

Performance Curve

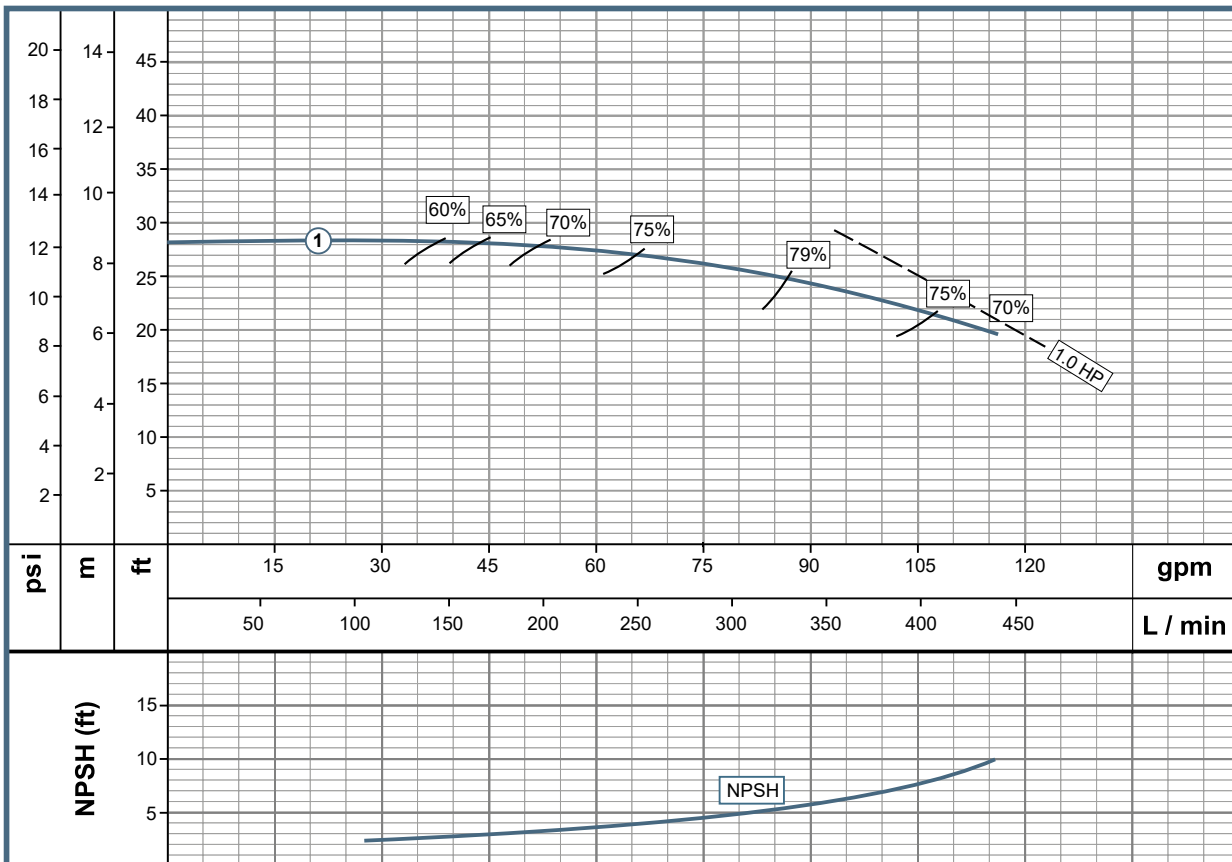

TEFC Enclosure as standard configuration.
SS= Stainless Steel.
Technical specifications are subject to change without prior notice.

Pump Features						
Pump Type	Design			Impeller		
End Suction	Close Coupled / Frame Mounted			Enclosed / Cast Iron / SS		
Stages	Mechanical Seal			Fluid temperature range		
1	1 1/4" T1			158° F (70° C)		
MODEL	Ref. Cast Iron Impeller	Ref. SS Impeller	Ø Suction	Ø Discharge	Ø Impeller	
1	GE 1.5B 10-4	1B0468	1B0468S	2" NPT	1 1/2" NPT	6.000"
2	GE 1.5B 15-4	1B0469	1B0469S	2" NPT	1 1/2" NPT	6.500"
3	GE 1.5B 20-4	1B0470	1B0470S	2" NPT	1 1/2" NPT	7.100"
3	GU 1.5B 1	1B0187	1B0187S	2" NPT	1 1/2" NPT	7.100"

Motor Features			
Drive		Speed (rpm)	Frequency (Hz)
Electric		1800 (nominal)	60
Power (HP)	Phase	Voltage (V)	Frame
1	3	230/460	143JM
1.5	3	230/460	145JM
2	3	230/460	145JM
Frame Mounted			

Performance Curve

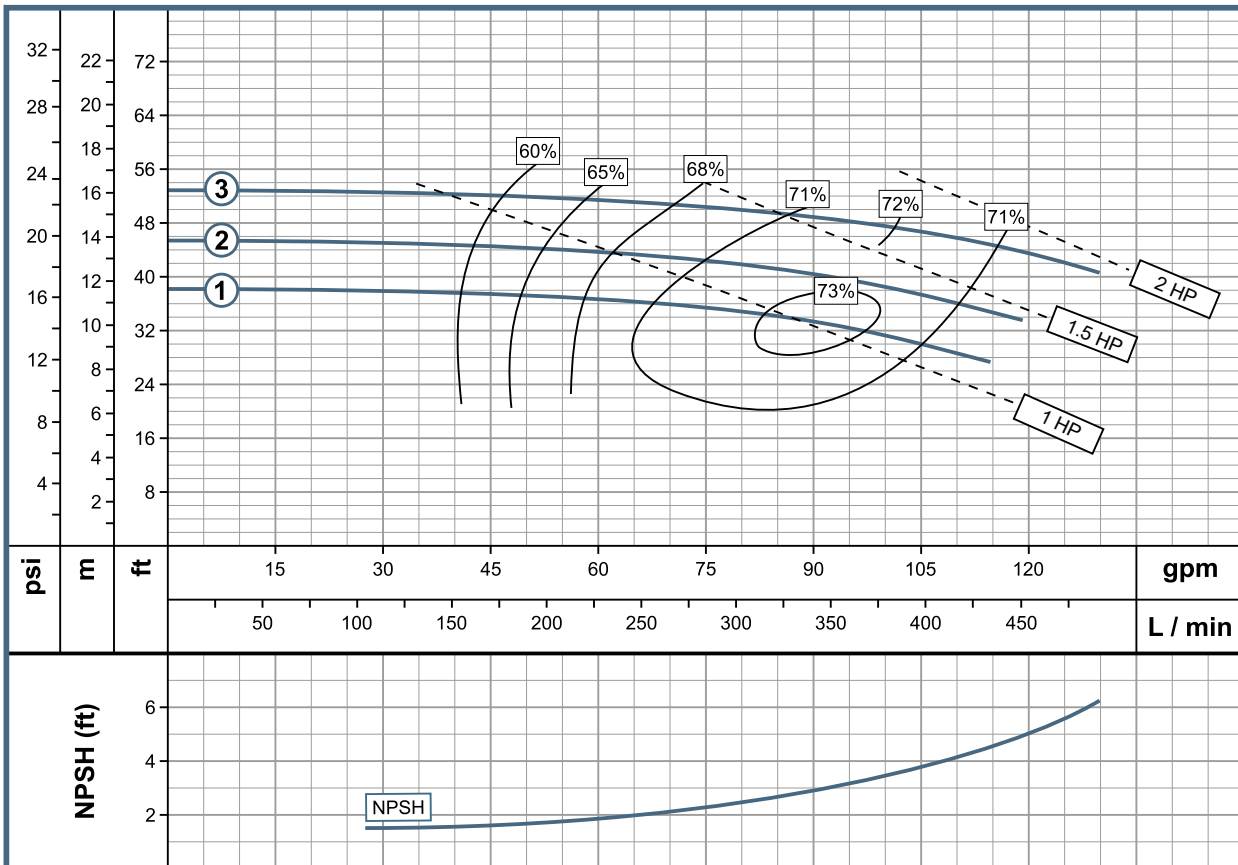

TEFC Enclosure as standard configuration.
 SS= Stainless Steel.

Technical specifications are subject to change without prior notice.

GS Line

- GE 1.5C 15-4
- GE 1.5C 20-4
- GE 1.5C 30-4
- GE 1.5C 50-4
- GU 1.5C 1



www.wdmpumps.com

Pump Features						
Pump Type	Design			Impeller		
End Suction	Close Coupled / Frame Mounted			Enclosed / Cast Iron / SS		
Stages	Mechanical Seal			Fluid temperature range		
1	1 1/4" T12			158° F (70° C)		
MODEL	Ref. Cast Iron Impeller	Ref. SS Impeller	Ø Suction	Ø Discharge	Ø Impeller	
1	GE 1.5C 15-4	1B0237	1B0237S	2" NPT	1 1/2" NPT	7.000"
2	GE 1.5C 20-4	1B0238	1B0238S	2" NPT	1 1/2" NPT	7.600"
3	GE 1.5C 30-4	1B0239	1B0239S	2" NPT	1 1/2" NPT	8.500"
4	GE 1.5C 50-4	1B0240	1B0240S	2" NPT	1 1/2" NPT	9.600"
4	GU 1.5C1	1B0100	1B0100S	2" NPT	2 1/2" NPT	9.600"

Motor Features			
Drive		Speed (rpm)	Frequency (Hz)
Electric		1800 (nominal)	60
Power (HP)	Phase	Voltage (V)	Frame
1,5	3	230/460	145JM
2	3	230/460	145JM
3	3	230/460	182JM
5	3	230/460	184JM
Frame Mounted			

Performance Curve

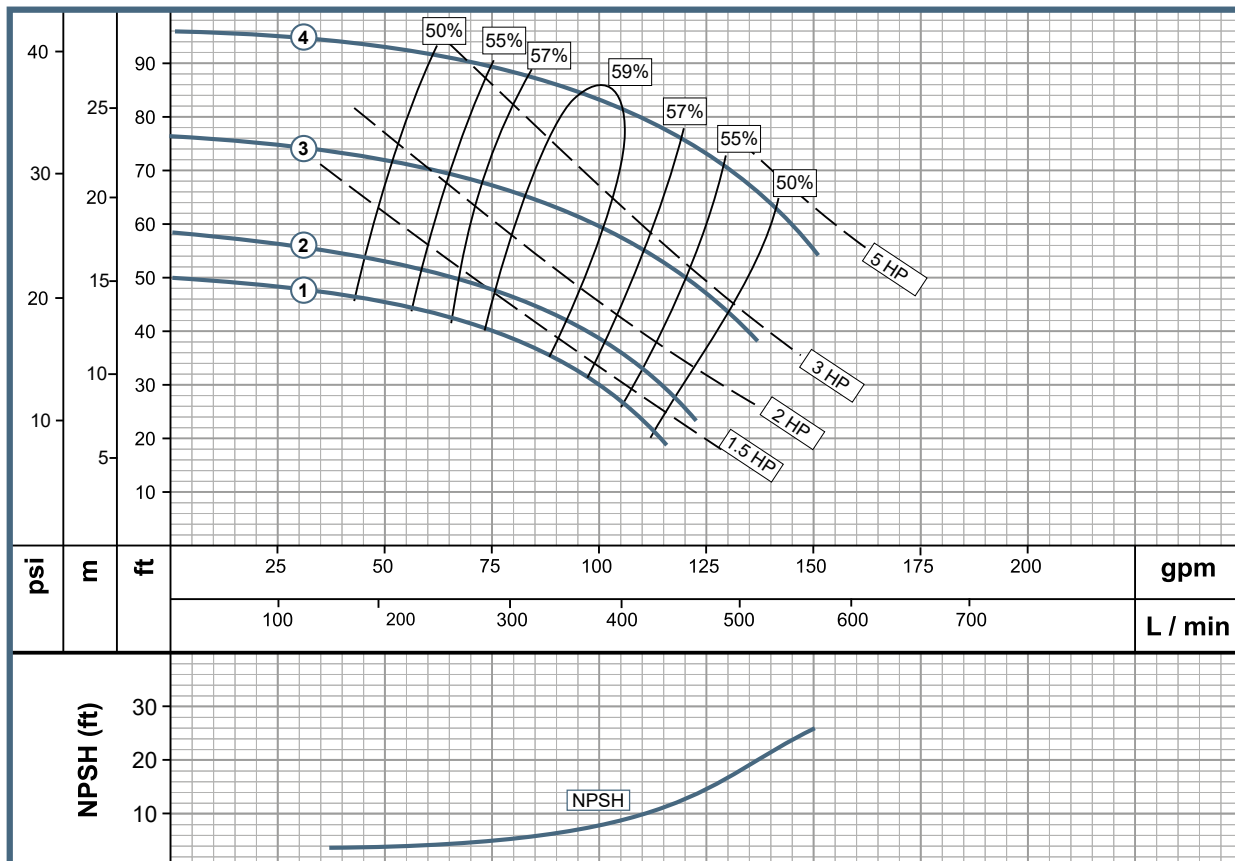

TEFC Enclosure as standard configuration.
SS= Stainless Steel.

Technical specifications are subject to change without prior notice.

Pump Features						
Pump Type	Design			Impeller		
End Suction	Close Coupled / Frame Mounted			Enclosed / Cast Iron / SS		
Stages	Mechanical Seal			Fluid temperature range		
1	1 1/4" T21			158° F (70° C)		
MODEL	Ref. Cast Iron Impeller	Ref. SS Impeller	Ø Suction	Ø Discharge	Ø Impeller	
1	GE 1.5D 30-4	1B0202	1B0202S	2" NPT	1 1/2" NPT	7.500"
2	GE 1.5D 50-4	1B0203	1B0203S	2" NPT	1 1/2" NPT	8.750"
3	GE 1.5D 75-4	1B0204	1B0204S	2" NPT	1 1/2" NPT	9.600"
3	GU 1.5D 1	1B0102	1B0102S	2" NPT	2 1/2" NPT	9.600"

Motor Features			
Drive		Speed (rpm)	Frequency (Hz)
Electric		1800 (nominal)	60
Power (HP)	Phase	Voltage (V)	Frame
3	3	230/460	182JM
5	3	230/460	184JM
7.5	3	230/460	213JM
Frame Mounted			

Performance Curve

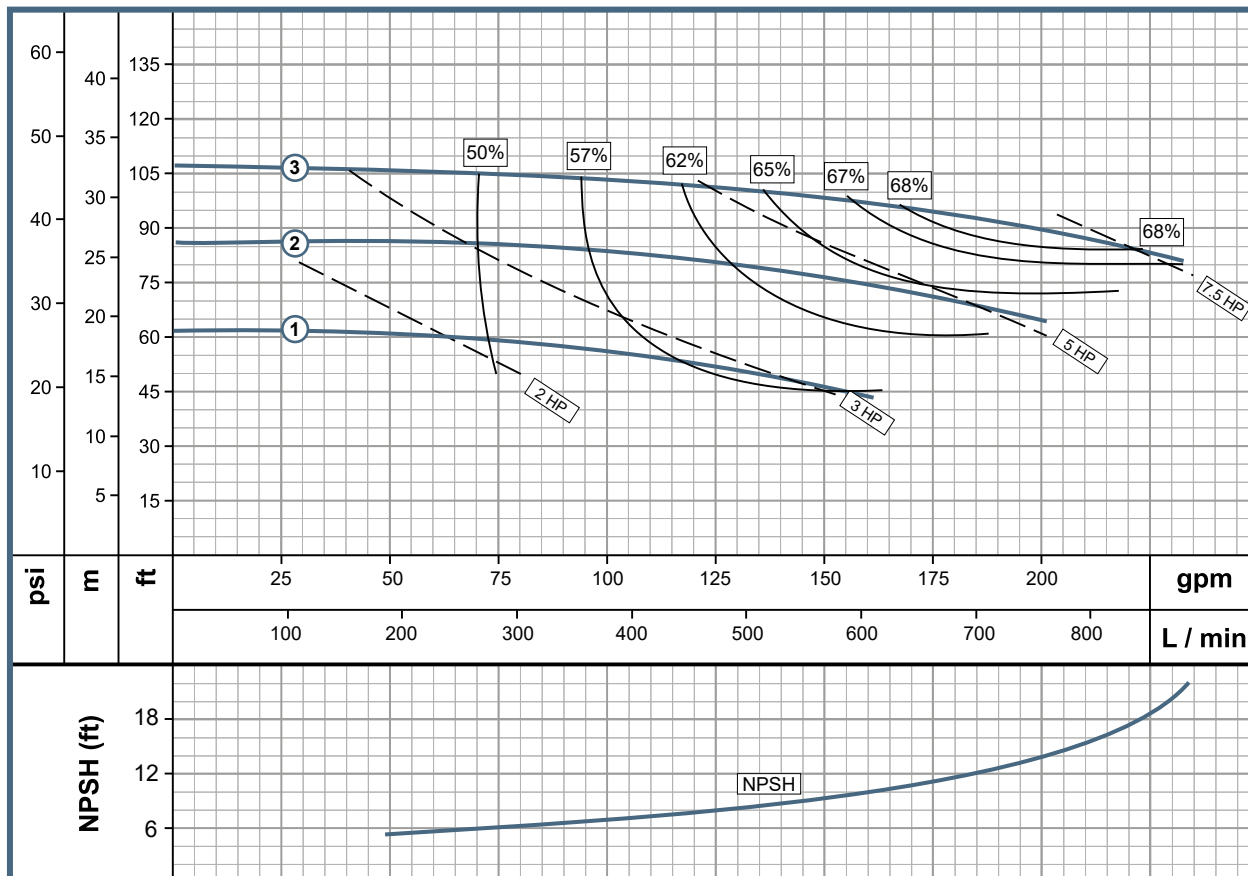

TEFC Enclosure as standard configuration.
 SS= Stainless Steel.

Technical specifications are subject to change without prior notice.

GS Line

- GE 2B 7-4
- GE 2B 10-4
- GE 2B 15-4
- GE 2B 20-4
- GE 2B 30-4
- GU 2B 1



www.wdmpumps.com

Pump Features					
Pump Type	Design			Impeller	
End Suction	Close Coupled / Frame Mounted			Enclosed / Cast Iron / SS	
Stages	Mechanical Seal			Fluid temperature range	
1	1 1/4" T12			158° F (70° C)	
MODEL	Ref. Cast Iron Impeller	Ref. SS Impeller	Ø Suction	Ø Discharge	Ø Impeller
1 GE 2B 7-4	1B0220	1B0220S	2 1/2" NPT	2" NPT	4.500"
2 GE 2B 10-4	1B0221	1B0221S	2 1/2" NPT	2" NPT	5.000"
3 GE 2B 15-4	1B0222	1B0222S	2 1/2" NPT	2" NPT	6.000"
4 GE 2B 20-4	1B0223	1B0223S	2 1/2" NPT	2" NPT	6.500"
5 GE 2B 30-4	1B0224	1B0224S	2 1/2" NPT	2" NPT	7.100"
5 GU 2B 1	1B0104	1B0104S	3 1/2" NPT	2" NPT	7.100"

Motor Features			
Drive		Speed (rpm)	Frequency (Hz)
Electric		1800 (nominal)	60
Power (HP)	Phases	Voltage (V)	Frame
0,75	3	230/460	56J
1	3	230/460	143JM
1,5	3	230/460	145JM
2	3	230/460	145JM
3	3	230/460	182JM
Frame Mounted			

Performance Curve

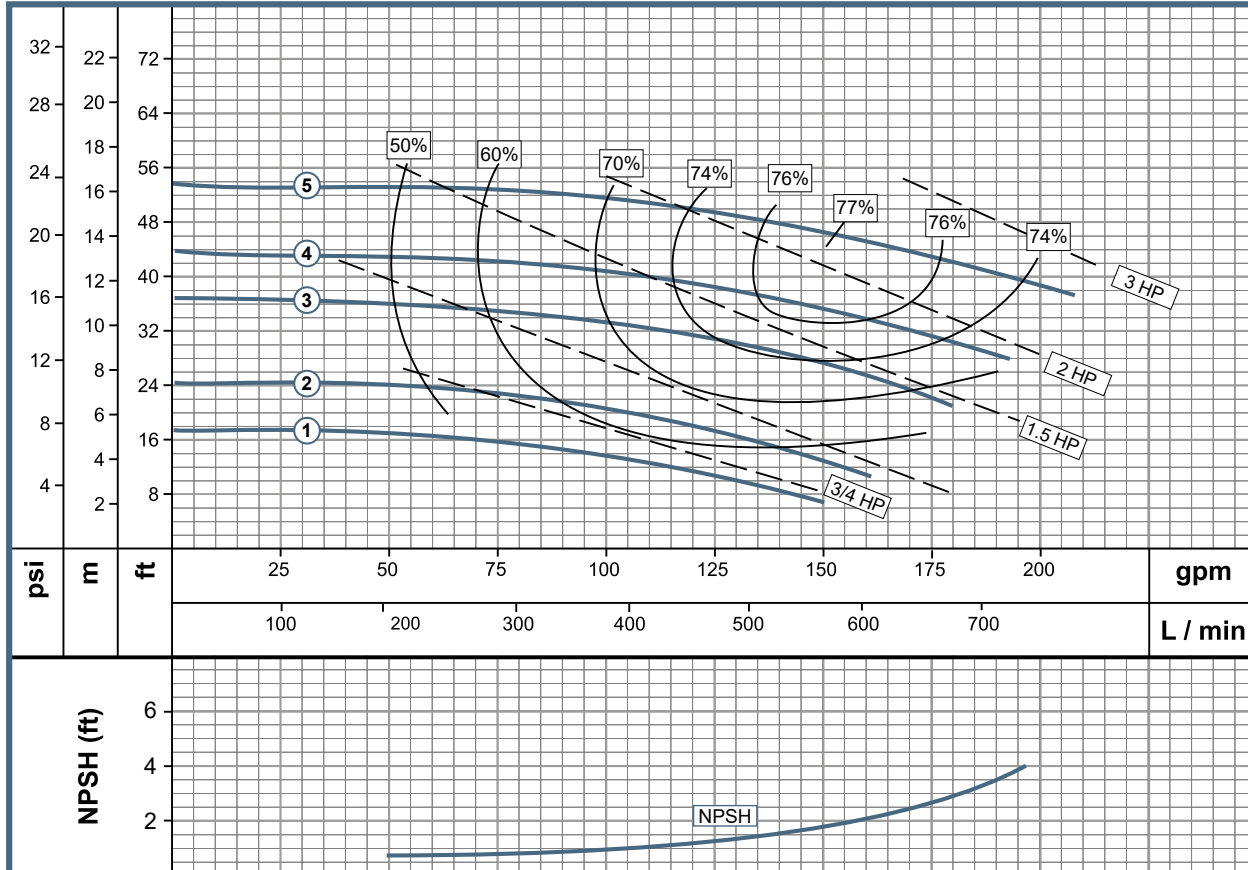

TEFC Enclosure as standard configuration.
SS= Stainless Steel.

Technical specifications are subject to change without prior notice.

Pump Features						
Pump Type	Design			Impeller		
End Suction	Close Coupled / Frame Mounted			Enclosed / Cast Iron / SS		
Stages	Mechanical Seal			Fluid temperature range		
1	1 1/4" T12			158° F (70° C)		
MODEL	Ref. Cast Iron Impeller	Ref. SS Impeller	Ø Suction	Ø Discharge	Ø Impeller	
1	GE 2C 20-4	1B0241	1B0241S	2 1/2" NPT	2" NPT	6.500"
2	GE 2C 30-4	1B0242	1B0242S	2 1/2" NPT	2" NPT	7.500"
3	GE 2C 50-4	1B0243	1B0243S	2 1/2" NPT	2" NPT	9.000"
4	GE 2C 75-4	1B0244	1B0244S	2 1/2" NPT	2" NPT	9.600"
4	GU 2C 1	1B0106	1B0106S	2 1/2" NPT	2" NPT	9.600"

Motor Features			
Drive		Speed (rpm)	Frequency (Hz)
Electric		1800 (nominal)	60
Power (HP)	Phase	Voltage (V)	Frame
2	3	230/460	145JM
3	3	230/460	182JM
5	3	230/460	184JM
7.5	3	230/460	213JM
Frame Mounted			

Performance Curve

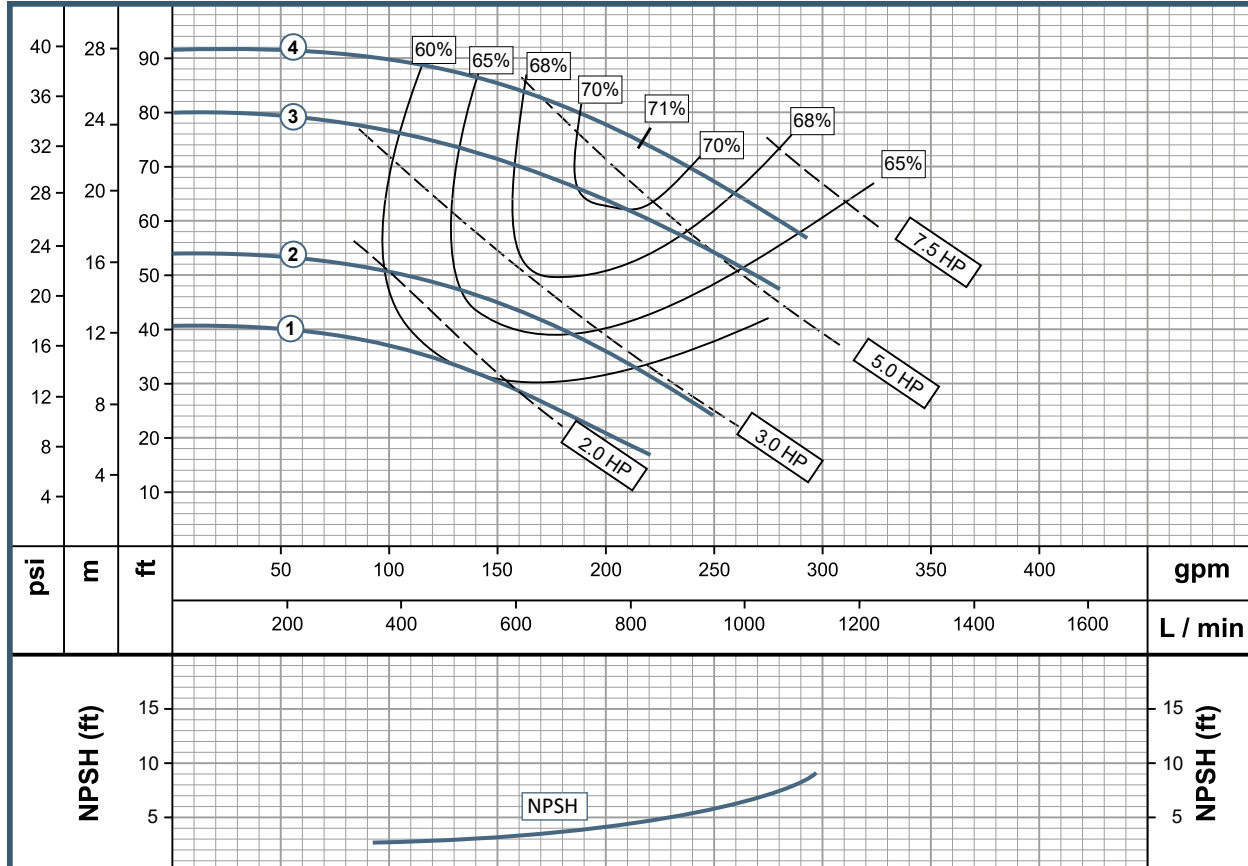

TEFC Enclosure as standard configuration.
 SS= Stainless Steel.
 Technical specifications are subject to change without prior notice.

GS Line

- GE 2E 50-4
- GE 2E 75-4
- GE 2E 100-4
- GE 2E 150-4
- GU 2E 1



www.wdmpumps.com

Pump Features						
Pump Type	Design			Impeller		
End Suction	Close Coupled / Frame Mounted			Enclosed / Cast Iron / SS		
Stages	Mechanical Seal			Fluid temperature range		
1	1 1/4" T12 (1,2,3) / 1 3/4" T21 (4)			158° F (70° C)		
MODEL	Ref. Cast Iron Impeller	Ref. SS Impeller	Ø Suction	Ø Discharge	Ø Impeller	
1	GE 2E 50-4	1B0065	1B0065S	2 1/2" NPT	2" NPT	9.625"
2	GE 2E 75-4	1B0066	1B0066S	2 1/2" NPT	2" NPT	10.500"
3	GE 2E 100-4	1B0067	1B0067S	2 1/2" NPT	2" NPT	11.500"
4	GE 2E 150-4	1B0068	1B0068S	2 1/2" NPT	2" NPT	12.100"
4	GU 2E 1	1B0124	1B0124S	2 1/2" NPT	2" NPT	12.100"

Motor Features			
Drive		Speed (rpm)	Frequency (Hz)
Electric		1800 (nominal)	60
Power (HP)	Phase	Voltage (V)	Frame
5	3	230/460	184JM
7.5	3	230/460	213JM
10	3	230/460	215JM
15	3	230/460	215JM
Frame Mounted			

Performance Curve

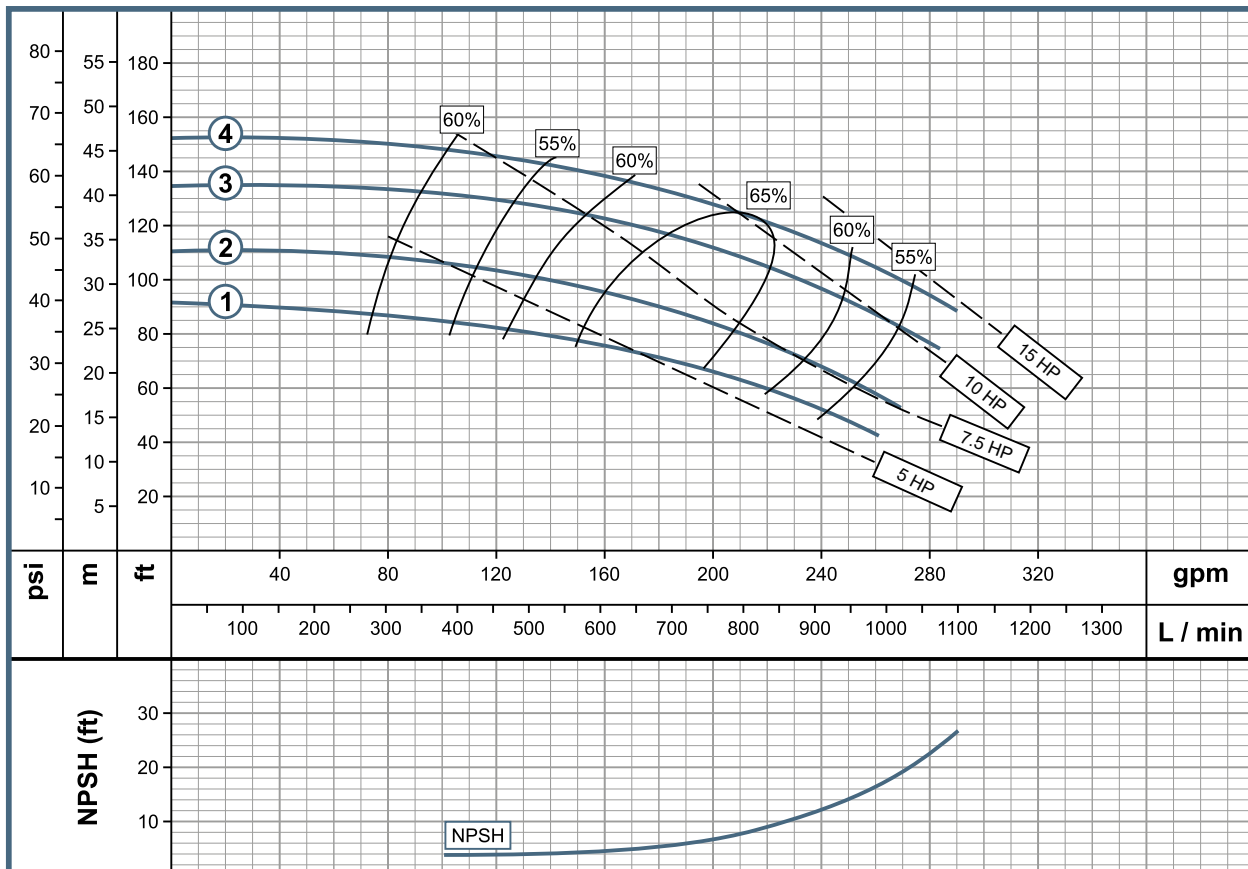

TEFC Enclosure as standard configuration.
SS= Stainless Steel.

Technical specifications are subject to change without prior notice.

Pump Features						
Pump Type	Design			Impeller		
End Suction	Close Coupled / Frame Mounted			Enclosed / Cast Iron / SS		
Stages	Mechanical Seal			Fluid temperature range		
1	1 1/4" T12			158° F (70° C)		
MODEL	Ref. Cast Iron Impeller	Ref. SS Impeller	Ø Suction	Ø Discharge	Ø Impeller	
1	GE 2.5B 10-4	1B0225	1B0225S	3" F	2 1/2"	4.880"
2	GE 2.5B 15-4	1B0226	1B0226S	3" F	2 1/2"	5.500"
3	GE 2.5B 20-4	1B0227	1B0227S	3" F	2 1/2"	6.000"
4	GE 2.5B 30-4	1B0228	1B0228S	3" F	2 1/2"	6.500"
5	GE 2.5B 50-4	1B0349	1B0349S	3" F	2 1/2"	7.100"
5	GU 2.5B 1	1B0108	1B0108S	3" F	2 1/2"	7.100"

Motor Features			
Drive		Speed (rpm)	Frequency (Hz)
Electric		1800 (nominal)	60
Power (HP)	Phase	Voltage (V)	Frame
1	3	230/460	143JM
1.5	3	230/460	145JM
2	3	230/460	145JM
3	3	230/460	182JM
5	3	230/460	184JM
Frame Mounted			

Performance Curve

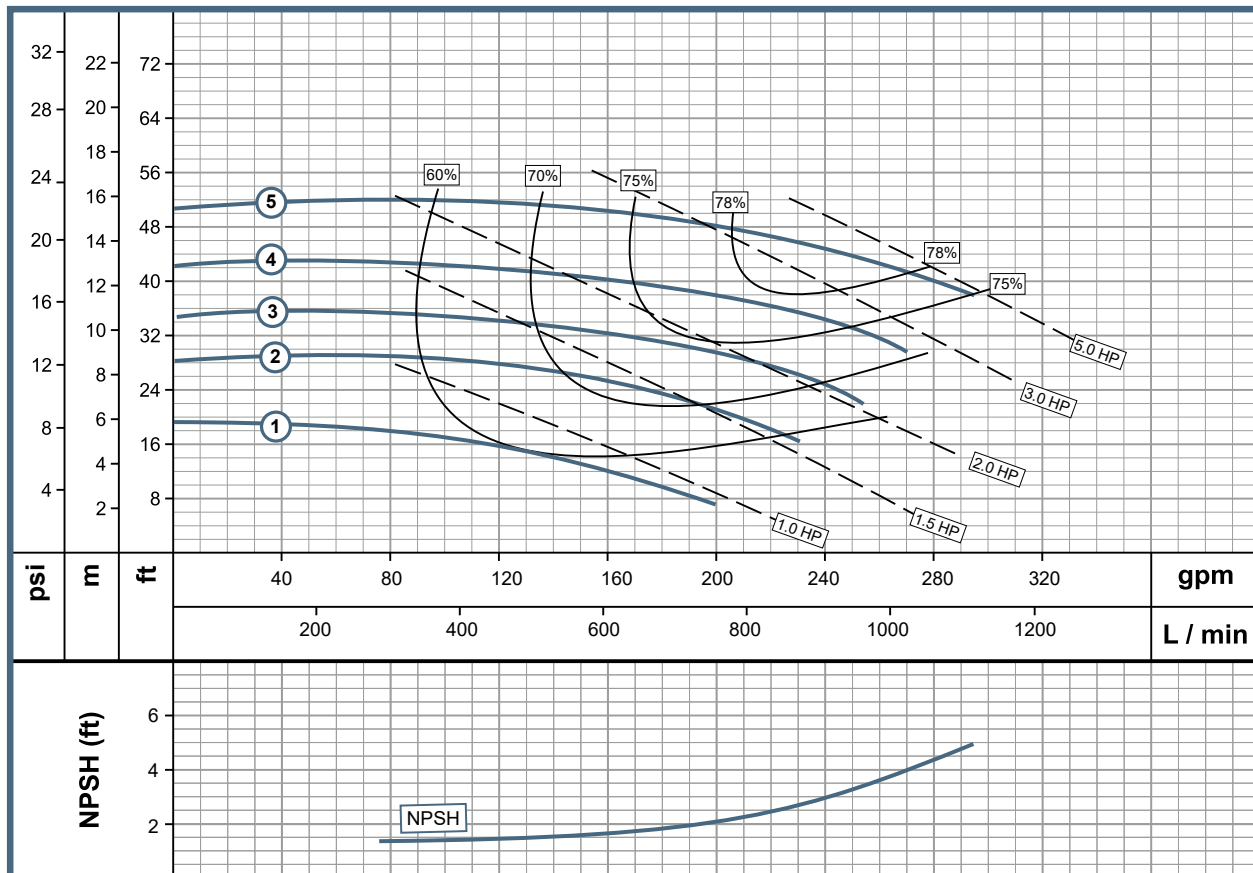

TEFC Enclosure as standard configuration.
 SS= Stainless Steel.
 Technical specifications are subject to change without prior notice.

GS Line

- GE 2.5C 20-4
- GE 2.5C 30-4
- GE 2.5C 50-4
- GE 2.5C 75-4
- GU 2.5C 1



www.wdmpumps.com

Pump Features						
Pump Type	Design			Impeller		
End Suction	Close Coupled / Frame Mounted			Enclosed / Cast Iron / SS		
Stages	Mechanical Seal			Fluid temperature range		
1	1 1/4" T12			158° F (70° C)		
MODEL	Ref. Cast Iron Impeller	Ref. SS Impeller	Ø Suction	Ø Discharge	Ø Impeller	
1	GE 2.5C 20-4	1B0245	1B0245S	3" F	2 1/2" F	5.875"
2	GE 2.5C 30-4	1B0246	1B0246S	3" F	2 1/2" F	6.750"
3	GE 2.5C 50-4	1B0247	1B0247S	3" F	2 1/2" F	8.000"
4	GE 2.5C 75-4	1B0248	1B0248S	3" F	2 1/2" F	9.000"
5	GE 2.5C 100-1	1B0262	1B0262S	3" F	2 1/2" F	9.600"
5	GU 2.5C 1	1B0110	1B0110S	3" F	2 1/2" F	9.600"

Motor Features			
Drive		Speed (rpm)	Frequency (Hz)
Electric		1800 (nominal)	60
Power (HP)	Phase	Voltage (V)	Frame
2	3	230/460	145JM
3	3	230/460	182JM
5	3	230/460	184JM
7.5	3	230/460	213JM
10	3	230/460	215JM
Frame Mounted			

Performance Curve

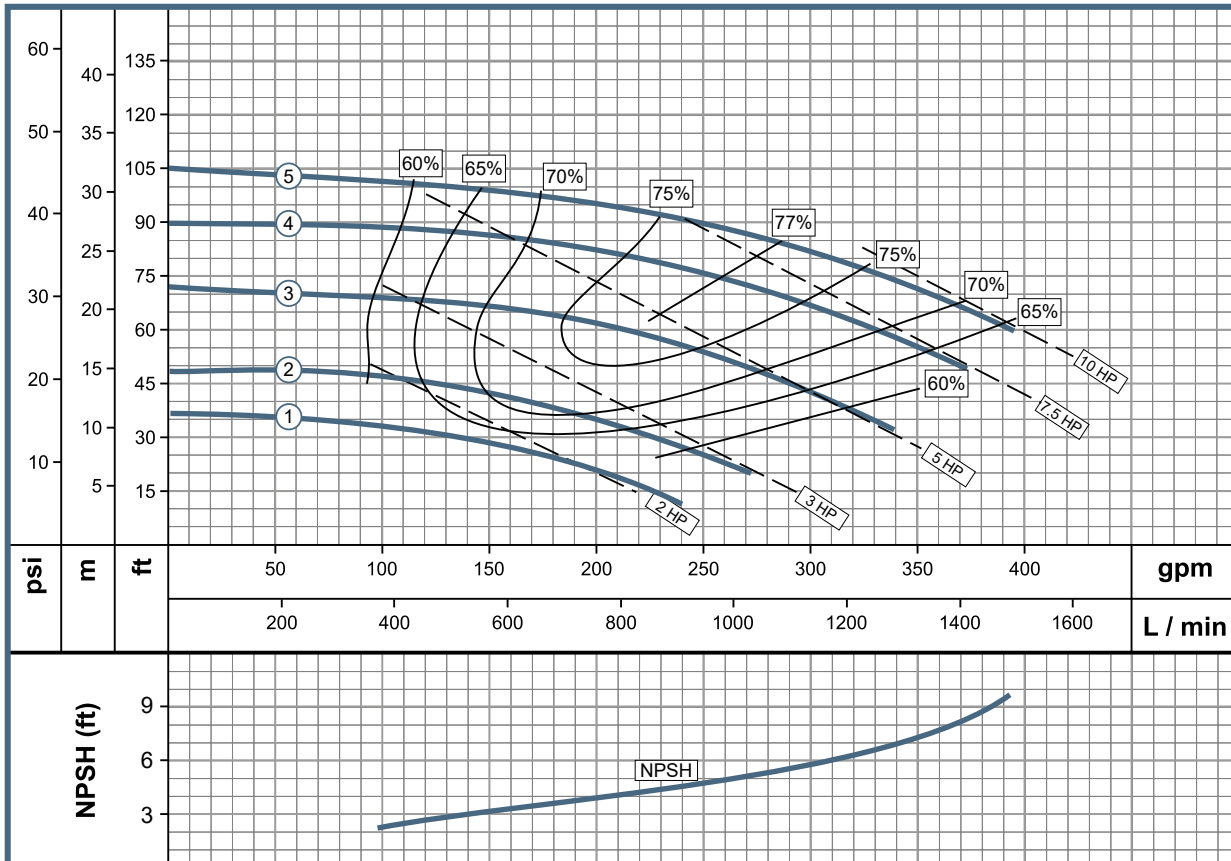

TEFC Enclosure as standard configuration.
SS= Stainless Steel.

Technical specifications are subject to change without prior notice.

Pump Features						
Pump Type	Design			Impeller		
End Suction	Close Coupled / Cast Iron / SS			Enclosed, SS		
Stages	Mechanical Seal			Fluid temperature range		
1	1 1/4" T12 (1,2) / 1 3/4" T21 (3,4)			158° F (70° C)		
MODEL	Ref. Cast Iron Impeller	Ref. SS Impeller	Ø Suction	Ø Discharge	Ø Impeller	
1	GE 2.5E 75-4	1B0069	1B0069S	3" F	2 1/2" F	9.000"
2	GE 2.5E 100-4	1B0070	1B0070S	3" F	2 1/2" F	10.000"
3	GE 2.5E 150-4	1B0071	1B0071S	3" F	2 1/2" F	11.000"
4	GE 2.5E 200-4	1B0072	1B0072S	3" F	2 1/2" F	12.093"
4	GU 2.5E 2	1B0125	1B0125S	3" F	2 1/2" F	12.093"

Motor Features			
Drive		Speed (rpm)	Frequency (Hz)
Electric		1800 (nominal)	60
Power (HP)	Phase	Voltage (V)	Frame
7.5	3	230/460	213JM
10	3	230/460	215JM
15	3	230/460	215JM
20	3	230/460	256JM
Frame Mounted			

Performance Curve

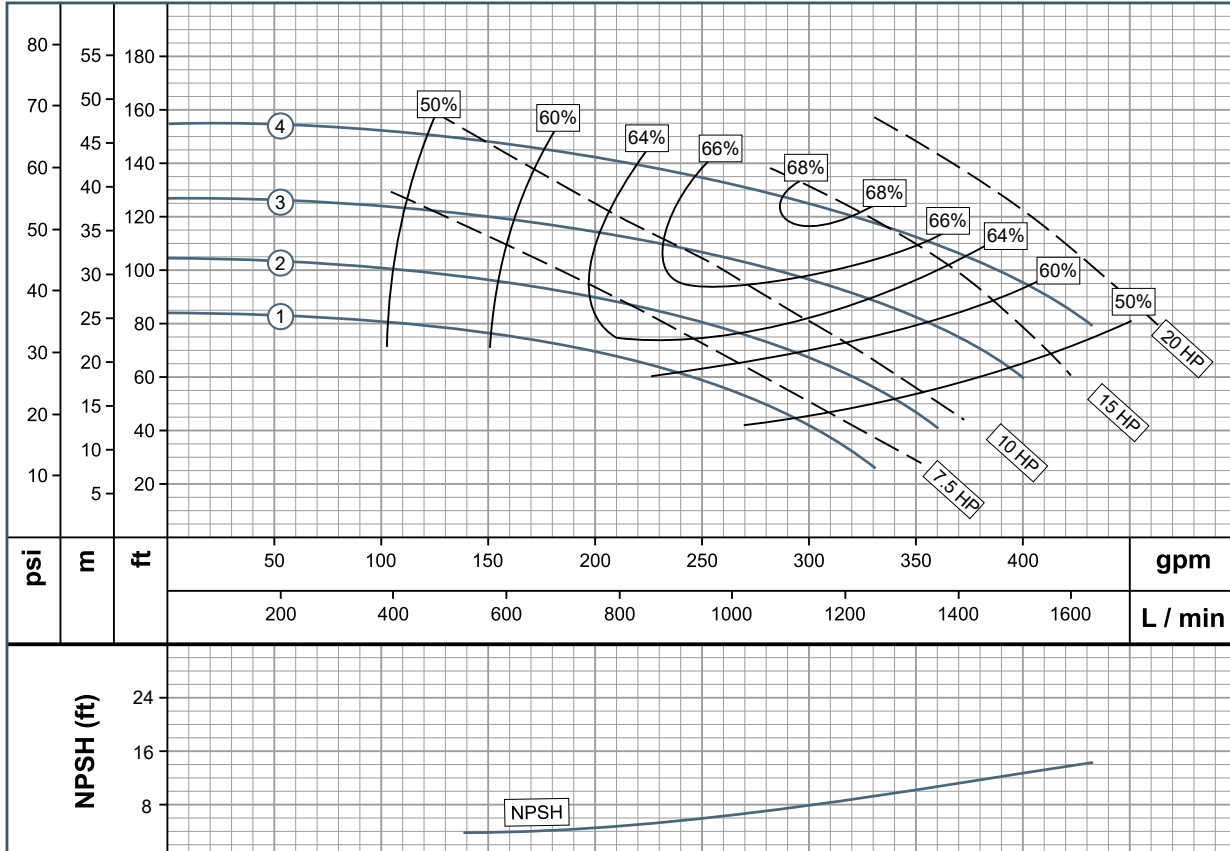

TEFC Enclosure as standard configuration.
 SS= Stainless Steel.
 Technical specifications are subject to change without prior notice.

GS Line

- GE 3B 15-4
- GE 3B 20-4
- GE 3B 30-4
- GE 3B 50-4
- GU 3B 1



www.wdmpumps.com

Pump Features						
Pump Type	Design			Impeller		
End Suction	Close Coupled / Frame Mounted			Enclosed / Cast Iron / SS		
Stages	Mechanical Seal			Fluid temperature range		
1	1 1/4" T12			158° F (70° C)		
MODEL	Ref. Cast Iron Impeller	Ref. SS Impeller	Ø Suction	Ø Discharge	Ø Impeller	
1	GE 3B 15-4	1B0230	1B0230S	4" F	3" F	5.000"
2	GE 3B 20-4	1B0231	1B0231S	4" F	3" F	5.500"
3	GE 3B 30-4	1B0232	1B0232S	4" F	3" F	6.000"
4	GE 3B 50-4	1B0233	1B0233S	4" F	3" F	7.100"
4	GU 3B 1	1B0112	1B0112S	4" F	3" F	7.100"

Motor Features			
Drive		Speed (rpm)	Frequency (Hz)
Electric		1800 (nominal)	60
Power (HP)	Phase	Voltage (V)	Frame
1.5	3	230/460	145JM
2	3	230/460	145JM
3	3	230/460	182JM
5	3	230/460	184JM
Frame Mounted			

Performance Curve

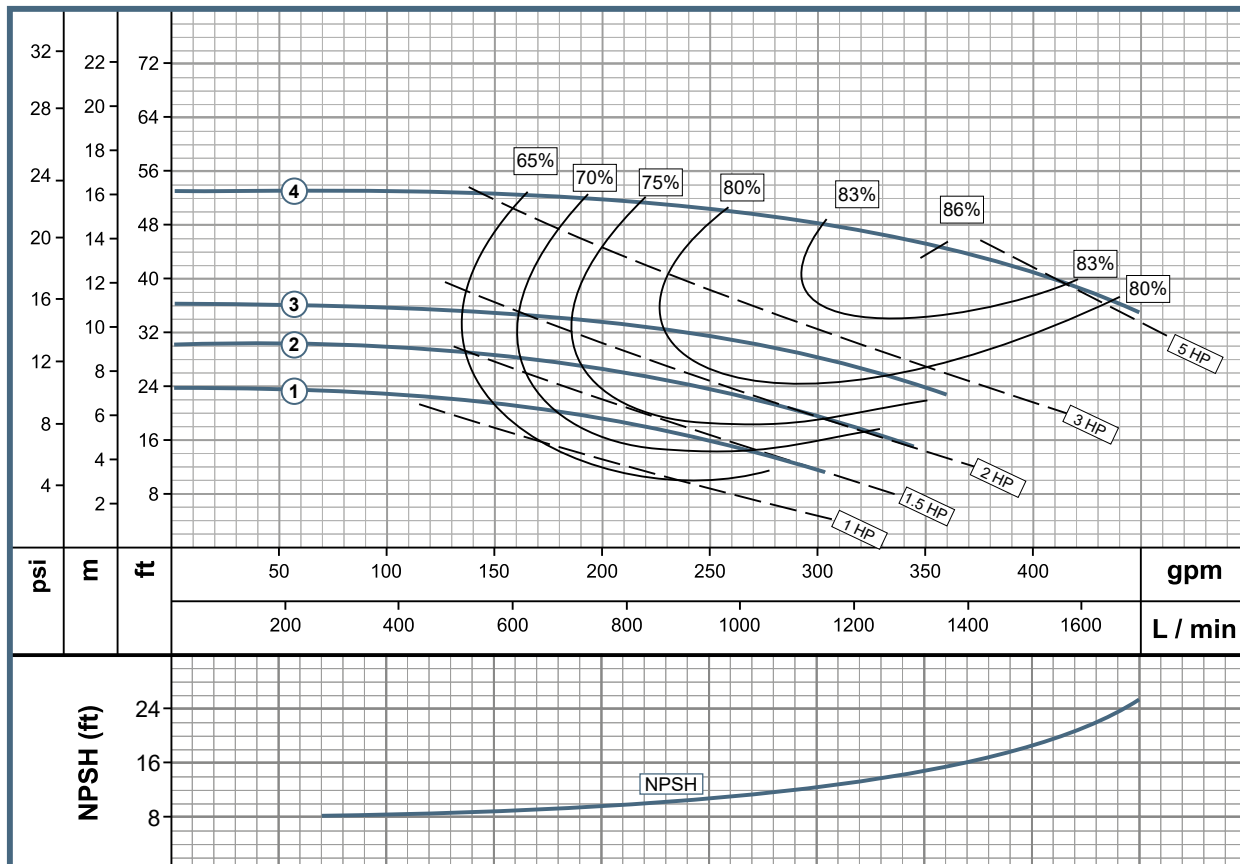

TEFC Enclosure as standard configuration.
SS= Stainless Steel.

Technical specifications are subject to change without prior notice.

Pump Features						
Pump Type	Design			Impeller		
End Suction	Close Coupled / Frame Mounted			Enclosed / Cast Iron / SS		
Stages	Mechanical Seal			Fluid temperature range		
1	1 1/4" T12			158° F (70° C)		
MODEL	Ref. Cast Iron Impeller	Ref. SS Impeller	Ø Suction	Ø Discharge	Ø Impeller	
1	GE 3C 30-4	1B0249	1B0249S	4" F	3" F	6.900"
2	GE 3C 50-4	1B0250	1B0250S	4" F	3" F	8.000"
3	GE 3C 75-4	1B0251	1B0251S	4" F	3" F	9.000"
4	GE 3C 100-4	1B0252	1B0252S	4" F	3" F	9.600"
4	GU 3C 1	1B0114	1B0114S	4" F	3" F	9.600"

Motor Features			
Drive		Speed (rpm)	Frequency (Hz)
Electric		1800 (nominal)	60
Power (HP)	Phase	Voltage (V)	Frame
3	3	230/460	182JM
5	3	230/460	184JM
7.5	3	230/460	213JM
10	3	230/460	215JM
Frame Mounted			

Performance Curve

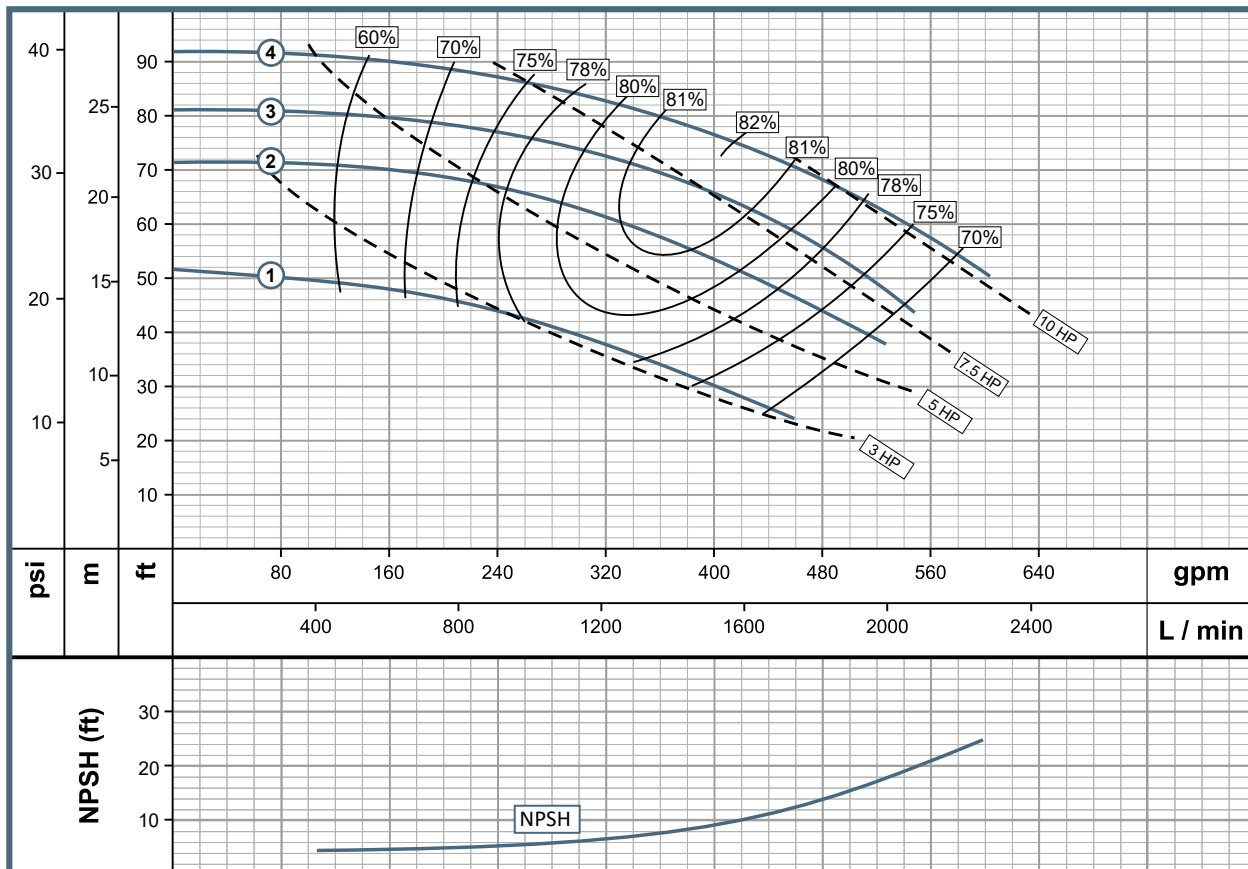

TEFC Enclosure as standard configuration.
 SS= Stainless Steel.
 Technical specifications are subject to change without prior notice.

GS Line

- GE 3E 100-4
- GE 3E 150-4
- GE 3E 200-4
- GE 3E 250-4
- GU 3E 2



www.wdmpumps.com

Pump Features						
Pump Type	Design			Impeller		
End Suction	Close Coupled, Frame Mounted			Enclosed / Cast Iron / SS		
Stages	Mechanical Seal			Fluid temperature range		
1	1 1/4" T12 (1) / 1 3/4" T21 (2,3,4)			158° F (70° C)		
MODEL	Ref. Cast Iron Impeller	Ref. SS Impeller	Ø Suction	Ø Discharge	Ø Impeller	
1	GE 3E 100-4	1B0073	1B0073S	4" F	3" F	9.500"
2	GE 3E 150-4	1B0074	1B0074S	4" F	3" F	10.500"
3	GE 3E 200-4	1B0075	1B0075S	4" F	3" F	11.500"
4	GE 3E 250-4	1B0076	1B0076S	4" F	3" F	12.093"
4	GU 3E 2	1B0126	1B0126S	4" F	3" F	12.093"

Motor Features			
Drive		Speed (rpm)	Frequency (Hz)
Electric		1800 (nominal)	60
Power (HP)	Phase	Voltage (V)	Frame
10	3	230/460	215JM
15	3	230/460	215JM
20	3	230/460	256JM
25	3	230/460	284JM
Frame Mounted			

Performance Curve

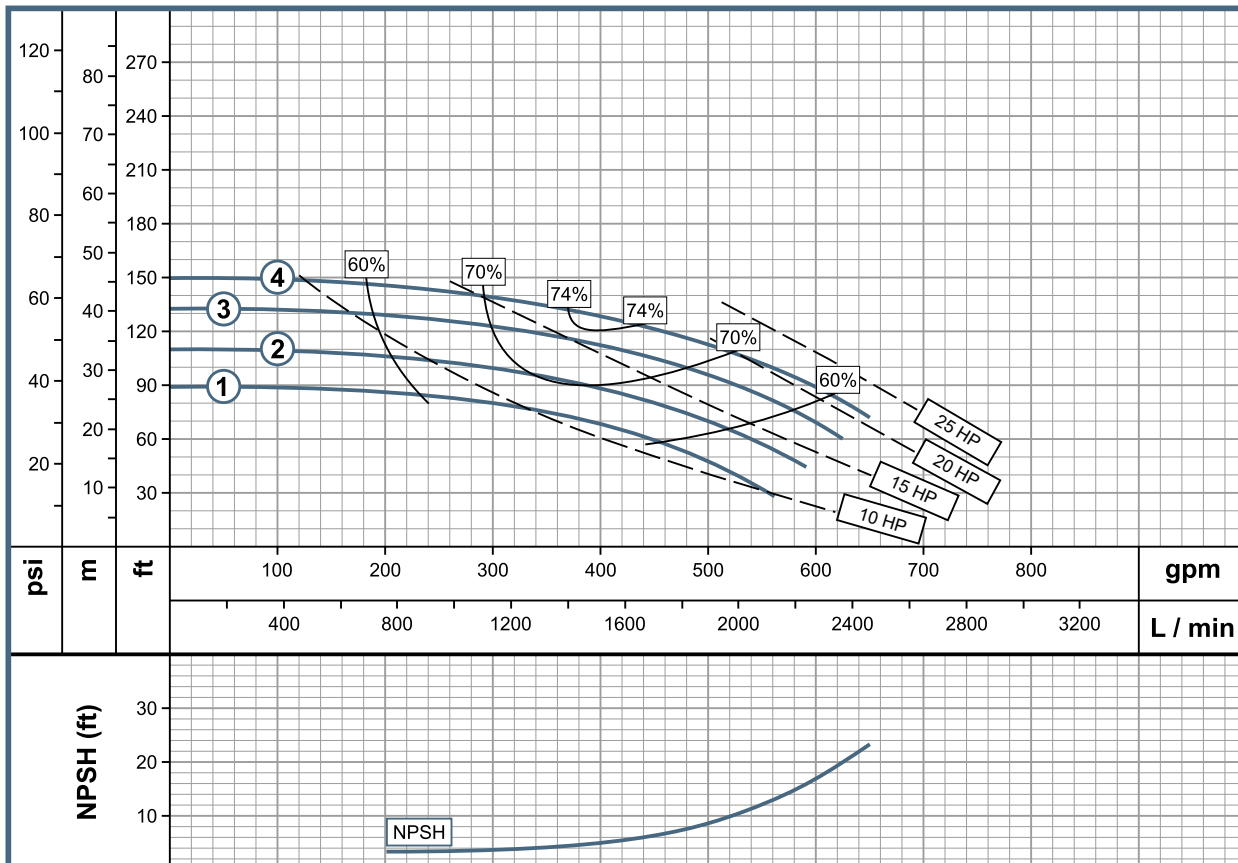

TEFC Enclosure as standard configuration.
SS= Stainless Steel.

Technical specifications are subject to change without prior notice.

Pump Features						
Pump Type	Design			Impeller		
End Suction	Close Coupled / Frame Mounted			Enclosed / Cast Iron / SS		
Stages	Mechanical Seal			Fluid temperature range		
1	1 1/4" T1 (1) / 1 3/4" T21 (2,3,4)			26.6°F to 225°F		
MODEL	Ref. Cast Iron Impeller	Ref. SS Impeller	Ø Suction	Ø Discharge	Ø Impeller	
1	GE 3F 150-4	1B0077	1B0077S	4" F	3" F	9.500"
2	GE 3F 200-4	1B0078	1B0078S	4" F	3" F	10.500"
3	GE 3F 250-4	1B0079	1B0079S	4" F	3" F	11.500"
4	GE 3F 300-4	1B0080	1B0080S	4" F	3" F	12.093"
4	GU 3F 2	1B0127	1B0127S	4" F	3" F	12.093"

Motor Features			
Drive		Speed (rpm)	Frequency (Hz)
Electric		1800 (nominal)	60
Power (HP)	Phase	Voltage (V)	Frame
15	3	230/460	215JM
20	3	230/460	256JM
25	3	230/460	284JM
30	3	230/460	286JM
Frame Mounted			

Performance Curve

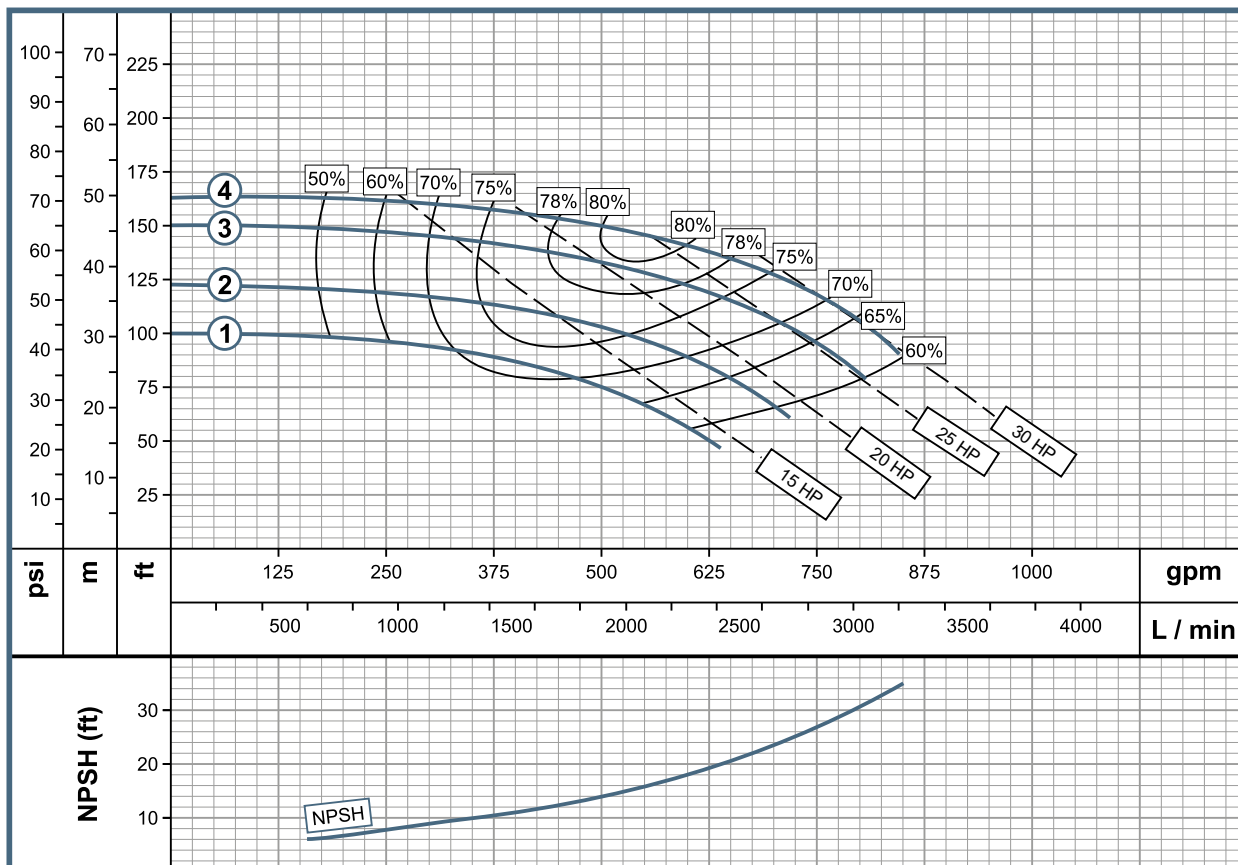

TEFC Enclosure as standard configuration.
 SS= Stainless Steel.
 Technical specifications are subject to change without prior notice.

GS Line

- GE 3G 250-4
- GE 3G 300-4
- GE 3G 400-4
- GE 3G 500-4
- GU 3G 3



www.wdmpumps.com

Pump Features						
Pump Type	Design			Impeller		
End Suction	Close Coupled / Frame Mounted			Enclosed / Cast Iron / SS		
Stages	Mechanical Seal			Fluid temperature range		
1	1 3/4" T21*			158° F (70° C)		
MODEL	Ref. Cast Iron Impeller	Ref. SS Impeller	Ø Suction	Ø Discharge	Ø Impeller	
1	GE 3G 250-4	1B0156	1B0156S	4" F	3" F	12.000"
2	GE 3G 300-4	1B0157	1B0157S	4" F	3" F	12.500"
3	GE 3G 400-4	1B0158	1B0158S	4" F	3" F	13.500"
4	GE 3G 500-4	1B0159	1B0159S	4" F	3" F	14.130"
4	GU 3G 3	1B0151	1B0151S	4" F	3" F	14.130"

Motor Features			
Drive		Speed (rpm)	Frequency (Hz)
Electric		1800 (nominal)	60
Power (HP)	Phase	Voltage (V)	Frame
25	3	230/460	284JM
30	3	230/460	286JM
40	3	230/460	324JM
50	3	230/460	326JM
Frame Mounted			

Performance Curve

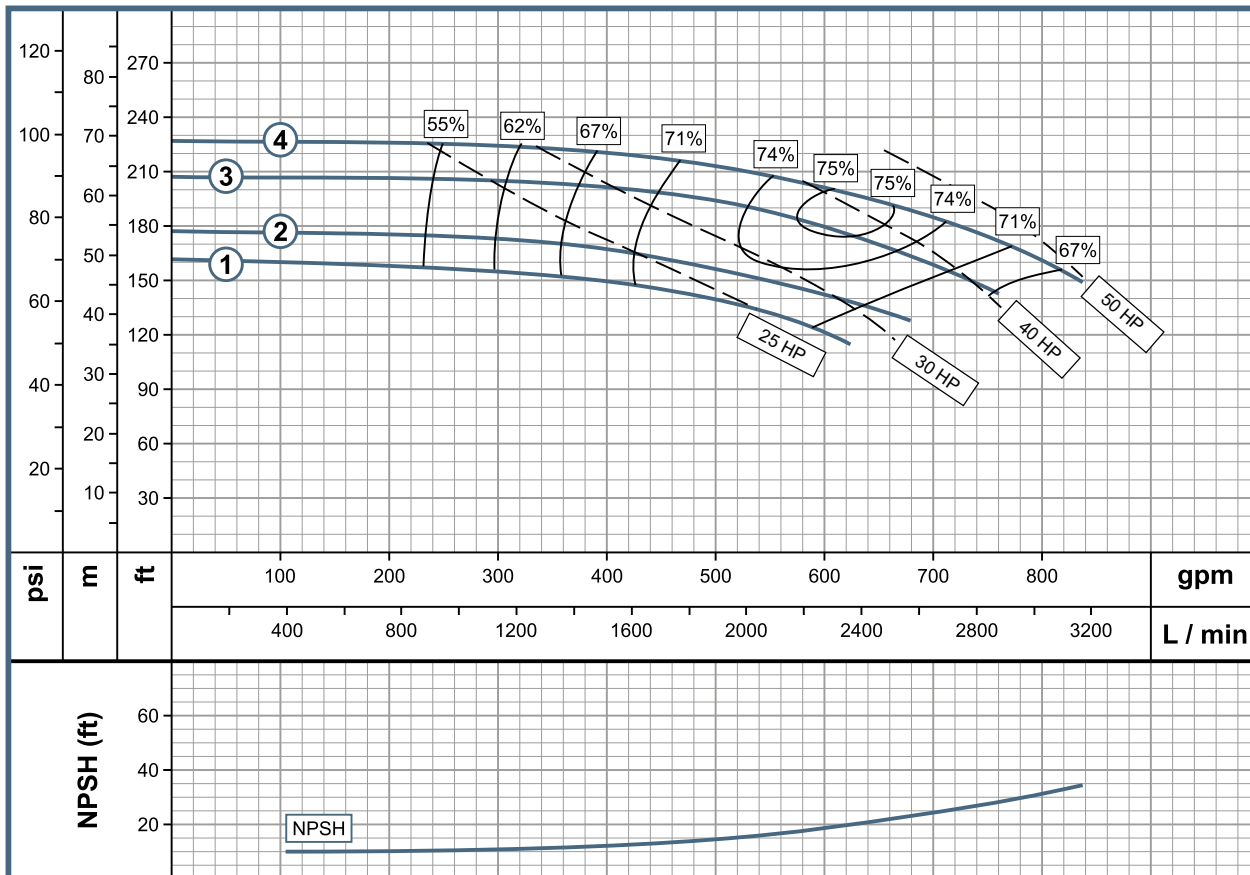

*Mechanical Seal 2 1/4" T21 for MODEL GU 363

TEFC Enclosure as standard configuration.
SS= Stainless Steel.

Technical specifications are subject to change without prior notice.

Pump Features						
Pump Type	Design			Impeller		
End Suction	Close Coupled / Frame Mounted			Enclosed / Cast Iron / SS		
Stages	Mechanical Seal			Fluid temperature range		
1	1 1/4" T12			158° F (70° C)		
MODEL	Ref. Cast Iron Impeller	Ref. SS Impeller	Ø Suction	Ø Discharge	Ø Impeller	
1	GE 4B 30-4	1B0234	1B0234S	5" F	4" F	5.500"
2	GE 4B 50-4	1B0235	1B0235S	5" F	4" F	6.500"
3	GE 4B 75-4	1B0236	1B0236S	5" F	4" F	7.100"
4	GU 4B 1	1B0119	1B0119S	5" F	4" F	7.100"

Motor Features			
Drive		Speed (rpm)	Frequency (Hz)
Electric		1800 (nominal)	60
Power (HP)	Phase	Voltage (V)	Frame
3	3	230/460	182JM
5	3	230/460	184JM
7.5	3	230/460	213JM
Frame Mounted			

Performance Curve

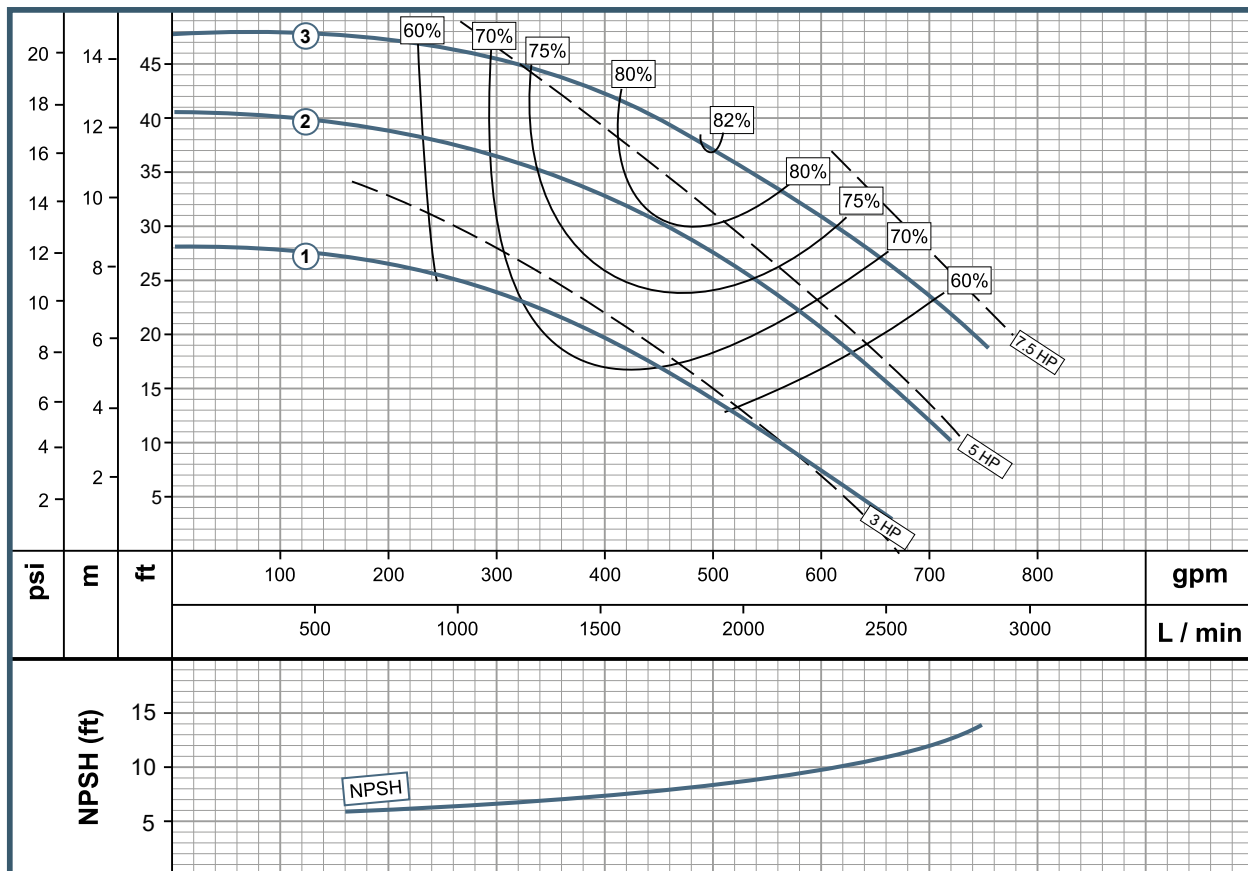

TEFC Enclosure as standard configuration.
 SS= Stainless Steel.
 Technical specifications are subject to change without prior notice.

GS Line

- GE 4C 75-4
- GE 4C 100-4
- GE 4C 150-4
- GE 4C 200-4
- GU 4C 1



www.wdmpumps.com

Pump Features						
Pump Type	Design			Impeller		
End Suction	Close Coupled / Frame Mounted			Enclosed / Cast Iron / SS		
Stages	Mechanical Seal			Fluid temperature range		
1	1 1/4" T12 (1,2) / 1 3/4" T21 (3,4)			158° F (70° C)		
MODEL	Ref. Cast Iron Impeller	Ref. SS Impeller	Ø Suction	Ø Discharge	Ø Impeller	
1	GE 4C 75-4	1B0263	1B0263S	5" F	4" F	7.000"
2	GE 4C 100-4	1B0264	1B0264S	5" F	4" F	8.000"
3	GE 4C 150-4	1B0265	1B0265S	5" F	4" F	9.000"
4	GE 4C 200-4	1B0266	1B0266S	5" F	4" F	9.600"
4	GU 4C 1	1B0116	1B0116S	5" F	4" F	9.600"

Motor Features			
Drive		Speed (rpm)	Frequency (Hz)
Electric		1800 (nominal)	60
Power (HP)	Phase	Voltage (V)	Frame
7.5	3	230/460	213JM
10	3	230/460	215JM
15	3	230/460	254JM
20	3	230/460	256JM
Frame Mounted			

Performance Curve

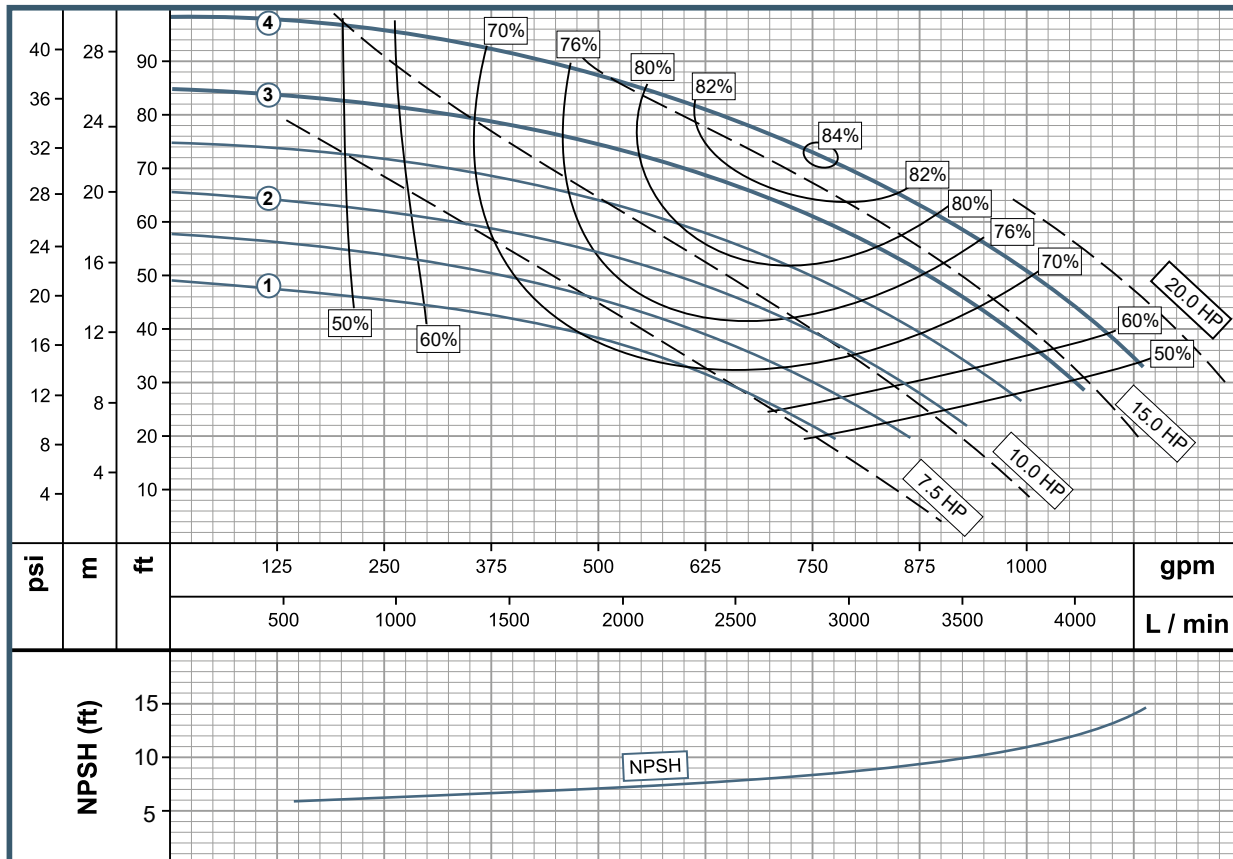

TEFC Enclosure as standard configuration.
SS= Stainless Steel.

Technical specifications are subject to change without prior notice.



GS Line

- GE 4E 150-4
- GE 4E 200-4
- GE 4E 250-4
- GE 4E 300-4
- GE 4E 400-4
- GE 4E 500-4
- GU 4E 2

www.wdmpumps.com

Pump Features						
Pump Type	Design			Impeller		
End Suction	Close Coupled / Frame Mounted			Enclosed / Cast Iron / SS		
Stages	Mechanical Seal			Fluid temperature range		
1	1-1/4" T1 (1) / 1 3/4" T21 (2,3,4,5,6)			158° F (70° C)		
MODEL	Ref. Cast Iron Impeller	Ref. SS Impeller	Ø Suction	Ø Discharge	Ø Impeller	
1	GE 4E 150-4	1B0081	1B0081S	5" F	4" F	8.000"
2	GE 4E 200-4	1B0082	1B0082S	5" F	4" F	9.000"
3	GE 4E 250-4	1B0253	1B0253S	5" F	4" F	9.500"
4	GE 4E 300-4	1B0083	1B0083S	5" F	4" F	10.000"
5	GE 4E 400-4	1B0084	1B0084S	5" F	4" F	11.000"
6	GE 4E 500-4	1B0085	1B0085S	5" F	4" F	12.100"
6	GU 4E 2	1B0128	1B0128S	5" F	4" F	12.100"

Motor Features			
Drive		Speed (rpm)	Frequency (Hz)
Electric		1800 (nominal)	60
Power (HP)	Phase	Voltage (V)	Frame
15	3	230/460	215JM
20	3	230/460	256JM
25	3	230/460	284JM
30	3	230/460	286JM
40	3	230/460	324JM
50	3	230/460	326JM
Frame Mounted			

Performance Curve

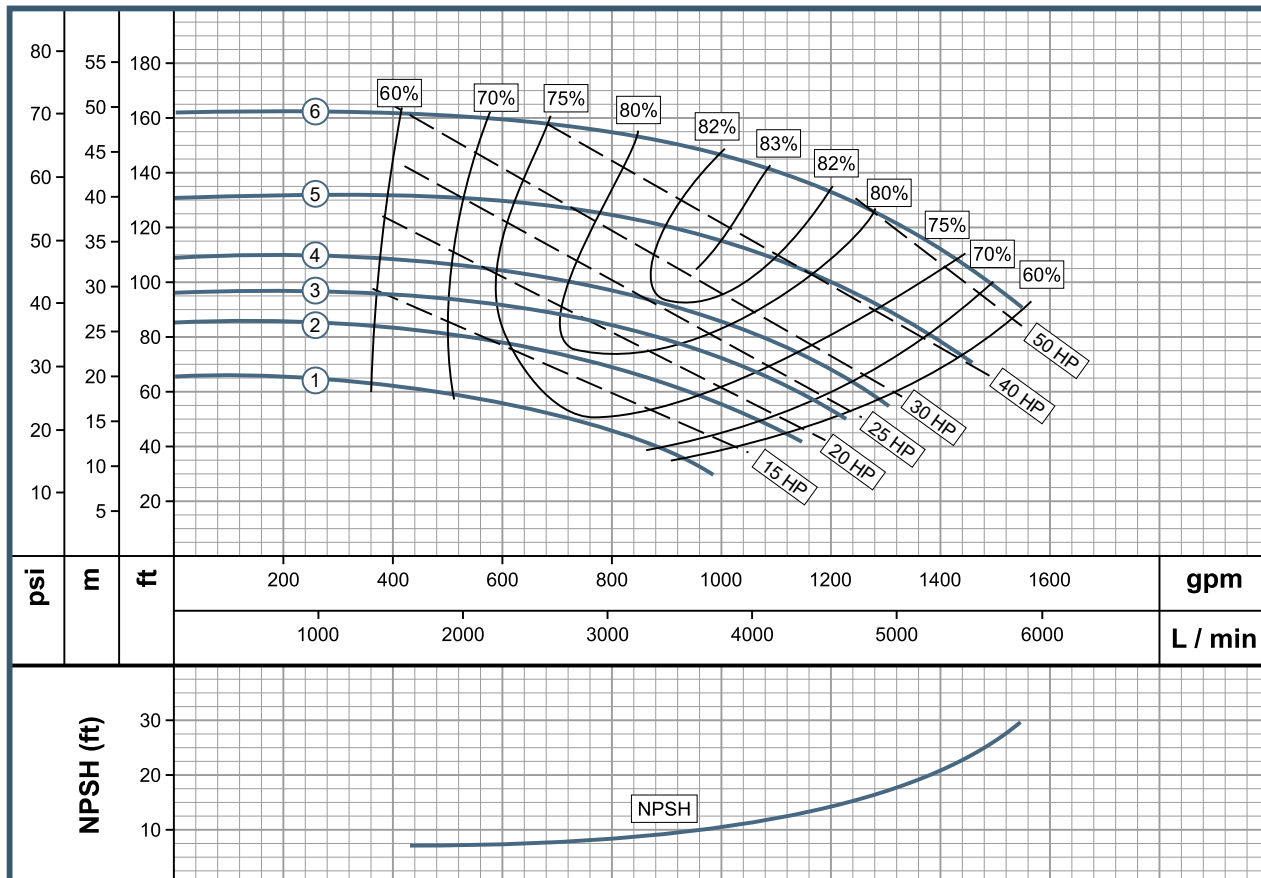

TEFC Enclosure as standard configuration.
SS= Stainless Steel.

Technical specifications are subject to change without prior notice.

GS Line

- GE 4G 400-4
- GE 4G 500-4
- GE 4G 600-4
- GE 4G 750-4
- GU 4G 3



www.wdmpumps.com

Pump Features						
Pump Type	Design			Impeller		
End Suction	Close Coupled / Frame Mounted			Enclosed / Cast Iron / SS		
Stages	Mechanical Seal			Fluid temperature range		
1	1 3/4" T21			158° F (70° C)		
MODEL	Ref. Cast Iron Impeller	Ref. SS Impeller	Ø Suction	Ø Discharge	Ø Impeller	
1	GE 4G 400-4	1B0160	1B0160S	5" F	4" F	12.750"
2	GE 4G 500-4	1B0161	1B0161S	5" F	4" F	14.000"
3	GE 4G 600-4	1B0162	1B0162S	5" F	4" F	14.500"
4	GE 4G 750-4	1B0163	1B0163S	5" F	4" F	15.000"
4	GU 4G 3	1B0152	1B0152S	5" F	4" F	15.000"

Motor Features			
Drive		Speed (rpm)	Frequency (Hz)
Electric		1800 (nominal)	60
Power (HP)	Phase	Voltage (V)	Frame
40	3	230/460	324JM
50	3	230/460	326JM
60	3	230/460	364JM
75	3	230/460	365JP
Frame Mounted			

Performance Curve

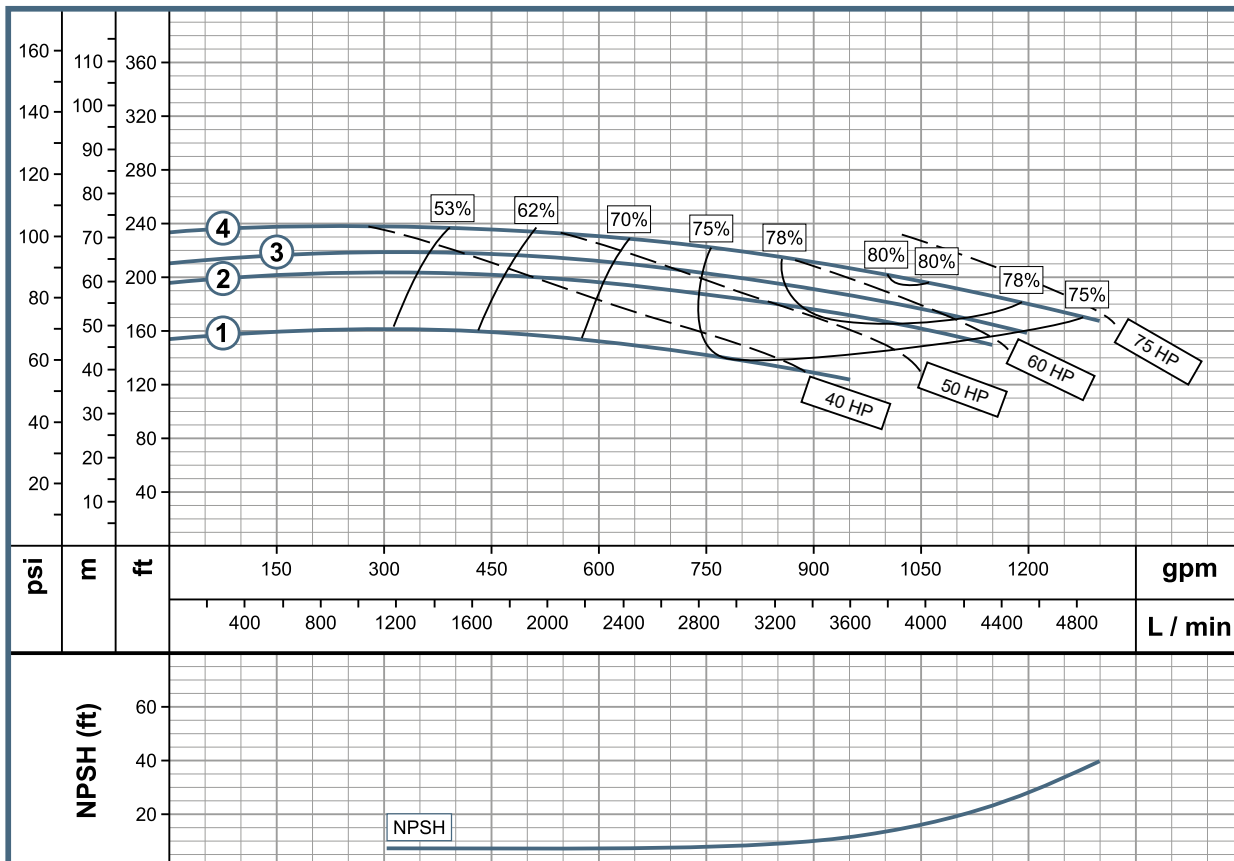

TEFC Enclosure as standard configuration.
SS= Stainless Steel.

Technical specifications are subject to change without prior notice.

Pump Features						
Pump Type	Design			Impeller		
End Suction	Close Coupled / Frame Mounted			Enclosed / Cast Iron / SS		
Stages	Mechanical Seal			Fluid temperature range		
1	1 1/4" T1 (1,2) / 1 3/4" T21 (3,4,5)			158° F (70° C)		
MODEL	Ref. Cast Iron Impeller	Ref. SS Impeller	Ø Suction	Ø Discharge	Ø Impeller	
1	GE 5C 100-4	1B0055	1B0055S	6" F	5" F	7.000"
2	GE 5C 150-4	1B0056	1B0056S	6" F	5" F	8.000"
3	GE 5C 200-4	1B0057	1B0057S	6" F	5" F	8.500"
4	GE 5C 250-4	1B0058	1B0058S	6" F	5" F	9.000"
5	GE 5C 300-4	1B0059	1B0059S	6" F	5" F	9.600"
5	GU 5C 2	1B0122	1B0122S	6" F	5" F	9.600"

Motor Features			
Drive		Speed (rpm)	Frequency (Hz)
Electric		1800 (nominal)	60
Power (HP)	Phase	Voltage (V)	Frame
10	3	230/460	215JM
15	3	230/460	215JM
20	3	230/460	256JM
25	3	230/460	284JM
30	3	230/460	286JM
Frame Mounted			

Performance Curve

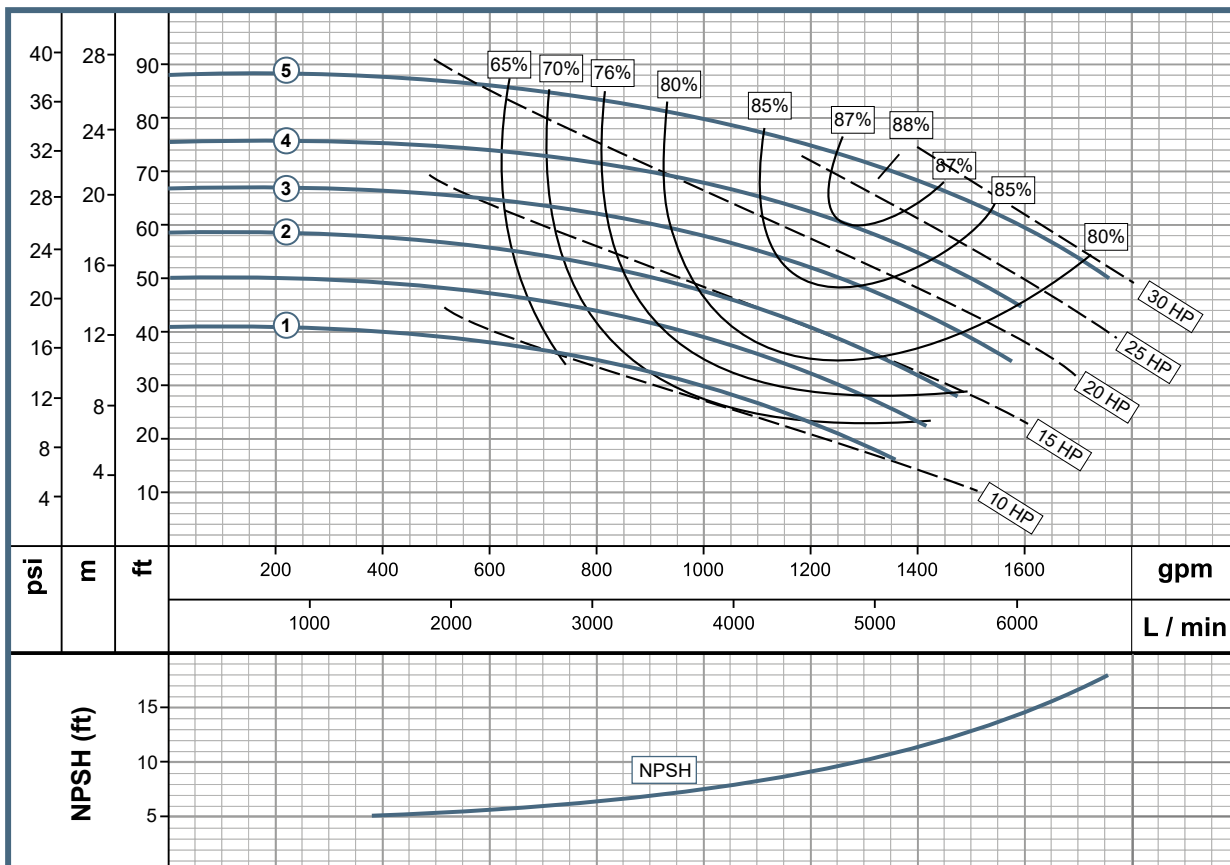

TEFC Enclosure as standard configuration.
 SS= Stainless Steel.

Technical specifications are subject to change without prior notice.

GS Line

- GE 5E 200-4
- GE 5E 300-4
- GE 5E 400-4
- GE 5E 500-4
- GU 5E 2



www.wdmpumps.com

Pump Features						
Pump Type	Design			Impeller		
End Suction	Close Coupled / Frame Mounted			Enclosed / Cast Iron / SS		
Stages	Mechanical Seal			Fluid temperature range		
1	1 3/4" T21			158° F (70° C)		
MODEL	Ref. Cast Iron Impeller	Ref. SS Impeller	Ø Suction	Ø Discharge	Ø Impeller	
1 GE 5E 200-4	1B0086	1B0086S	6" F	5" F	9.000"	
2 GE 5E 250-4	1B0254	1B0254S	6" F	5" F	9.600"	
3 GE 5E 300-4	1B0087	1B0087S	6" F	5" F	10.000"	
4 GE 5E 400-4	1B0088	1B0088S	6" F	5" F	11.000"	
5 GE 5E 500-4	1B0089	1B0089S	6" F	5" F	12.093"	
5 GU 5E 2	1B0129	1B0129S	6" F	5" F	12.093"	

Motor Features			
Drive		Speed (rpm)	Frequency (Hz)
Electric		1800 (nominal)	60
Power (HP)	Phase	Voltage (V)	Frame
20	3	230/460	256JM
25	3	230/460	284JM
30	3	230/460	286JM
40	3	230/460	324JM
50	3	230/460	326JM
Frame Mounted			

Performance Curve

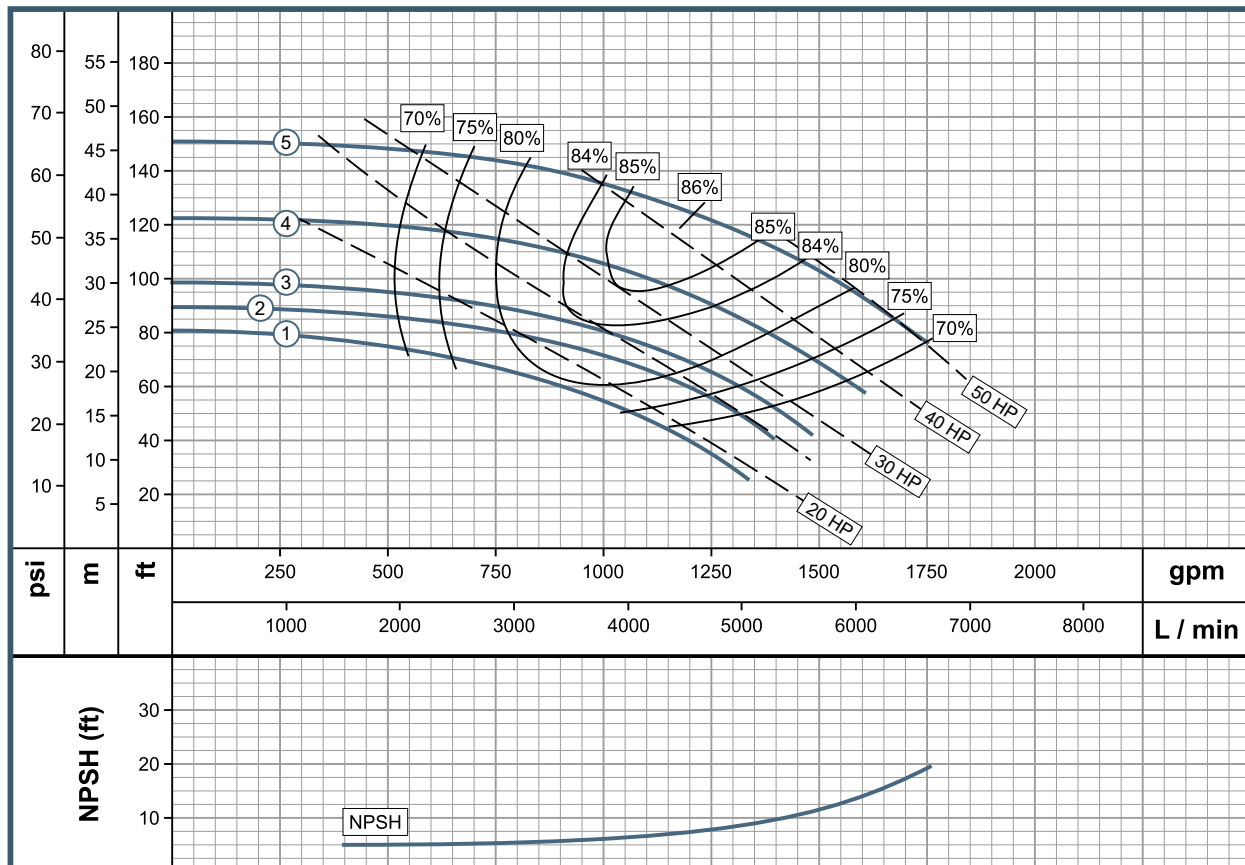

TEFC Enclosure as standard configuration.
SS= Stainless Steel.

Technical specifications are subject to change without prior notice.

Pump Features						
Pump Type	Design			Impeller		
End Suction	Close Coupled / Frame Mounted			Enclosed / Cast Iron / SS		
Stages	Mechanical Seal			Fluid temperature range		
1	1 3/4" T21 (1) / 2" T01 (2,3,4)*			26.6°F to 225°F		
MODEL	Ref. Cast Iron Impeller	Ref. SS Impeller	Ø Suction	Ø Discharge	Ø Impeller	
1	GE 5G 600-4	1B0164	1B0164S	6" F	5" F	12.400"
2	GE 5G 750-4	1B0165	1B0165S	6" F	5" F	13.000"
3	GE 5G 1000-4	1B0166	1B0166S	6" F	5" F	14.000"
4	GE 5G 1250-4	1B0167	1B0167S	6" F	5" F	15.000"
4	GU 5G 4	1B0153	1B0153S	6" F	5" F	15.000"

Motor Features			
Drive		Speed (rpm)	Frequency (Hz)
Electric		1800 (nominal)	60
Power (HP)	Phase	Voltage (V)	Frame
60	3	230/460	364JM
75	3	230/460	365JP
100	3	230/460	405JP
125	3	230/460	444JP
Frame Mounted			

Performance Curve

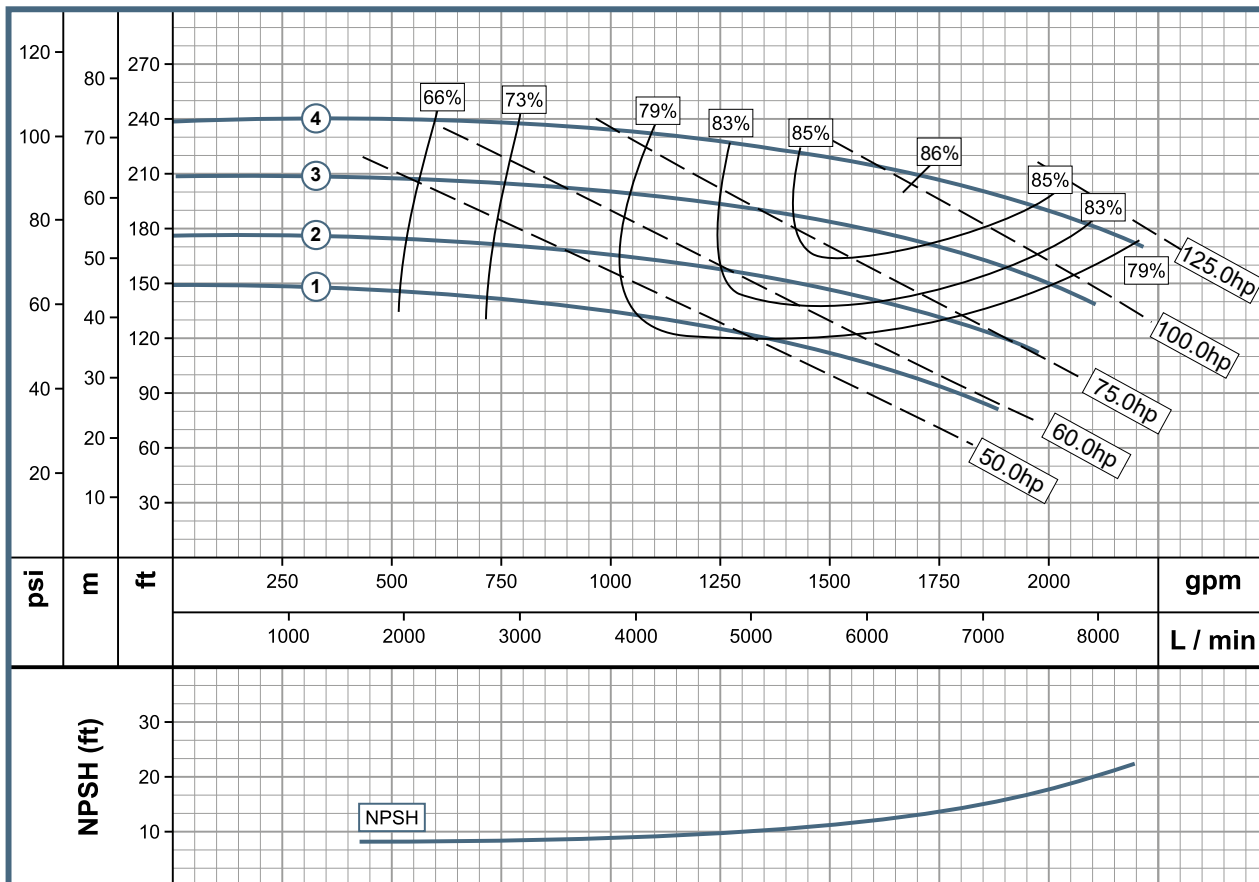

*Mechanical Seal 2 1/4" T21 for MODEL GU 5G 4

TEFC Enclosure as standard configuration.

SS= Stainless Steel.

Technical specifications are subject to change without prior notice.

GS Line

- GE 6C 150-4
- GE 6C 200-4
- GE 6C 250-4
- GE 6C 300-4
- GE 6C 400-4
- GU 6C 2



www.wdmpumps.com

Pump Features						
Pump Type	Design			Impeller		
End Suction	Close Coupled / Frame Mounted			Enclosed / Cast Iron / SS		
Stages	Mechanical Seal			Fluid temperature range		
1	1 3/4" T21			158° F (70° C)		
MODEL	Ref. Cast Iron Impeller	Ref. SS Impeller	Ø Suction	Ø Discharge	Ø Impeller	
1 GE 6C 150-4	1B0060	1B0060S	8" F	6" F	7.500"	
2 GE 6C 200-4	1B0061	1B0061S	8" F	6" F	8.000"	
3 GE 6C 250-4	1B0062	1B0062S	8" F	6" F	8.500"	
4 GE 6C 300-4	1B0063	1B0063S	8" F	6" F	9.000"	
5 GE 6C 400-4	1B0064	1B0064S	8" F	6" F	9.600"	
5 GU 6C 2	1B0123	1B0123S	8" F	6" F	9.600"	

Motor Features			
Drive		Speed (rpm)	Frequency (Hz)
Electric		1800 (nominal)	60
Power (HP)	Phase	Voltage (V)	Frame
15	3	230/460	215JM
20	3	230/460	256JM
25	3	230/460	284JM
30	3	230/460	286JM
40	3	230/460	324JM
Frame Mounted			

Performance Curve

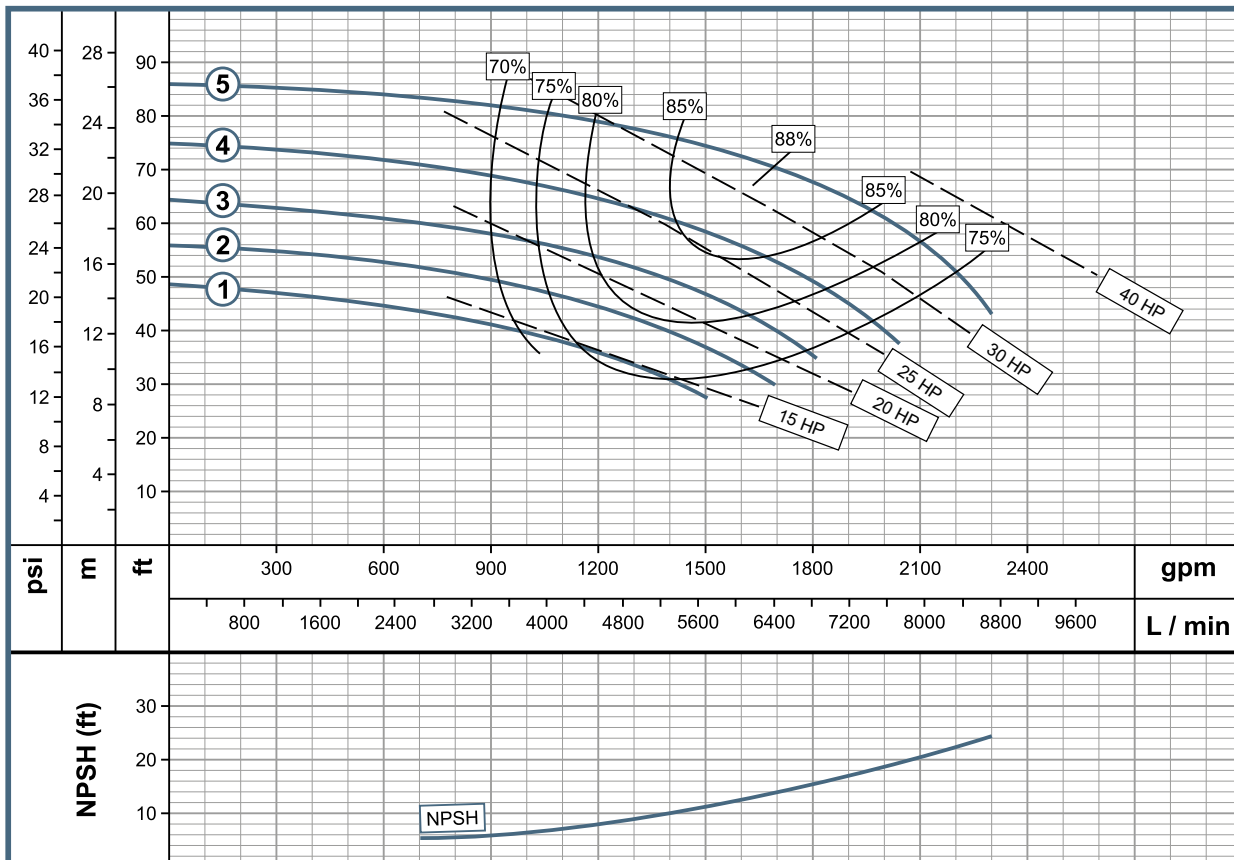

TEFC Enclosure as standard configuration.
SS= Stainless Steel.

Technical specifications are subject to change without prior notice.

Pump Features						
Pump Type	Design			Impeller		
End Suction	Close Coupled / Frame Mounted			Enclosed / Cast Iron / SS		
Stages	Mechanical Seal			Fluid temperature range		
1	1 3/4" T21 (1,2,3,4,5) / 2" T21 (6)*			158° F (70° C)		
MODEL	Ref. Cast Iron Impeller	Ref. SS Impeller	Ø Suction	Ø Discharge	Ø Impeller	
1	GE 6E 250-4	1B0090	1B0090S	8" F	6" F	9.000"
2	GE 6E 300-4	1B0255	1B0255S	8" F	6" F	9.500"
3	GE 6E 400-4	1B0091	1B0091S	8" F	6" F	10.000"
4	GE 6E 500-4	1B0256	1B0256S	8" F	6" F	10.500"
5	GE 6E 600-4	1B0092	1B0092S	8" F	6" F	11.000"
6	GE 6E 750-4	1B0093	1B0093S	8" F	6" F	12.000"
6	GU 6E 2	1B0130	1B0130S	8" F	6" F	12.100"

Motor Features			
Drive		Speed (rpm)	Frequency (Hz)
Electric		1800 (nominal)	60
Power (HP)	Phase	Voltage (V)	Frame
25	3	230/460	284JM
30	3	230/460	286JM
40	3	230/460	324JM
50	3	230/460	326JM
60	3	230/460	365JM
75	3	230/460	365JP
Frame Mounted			

Performance Curve

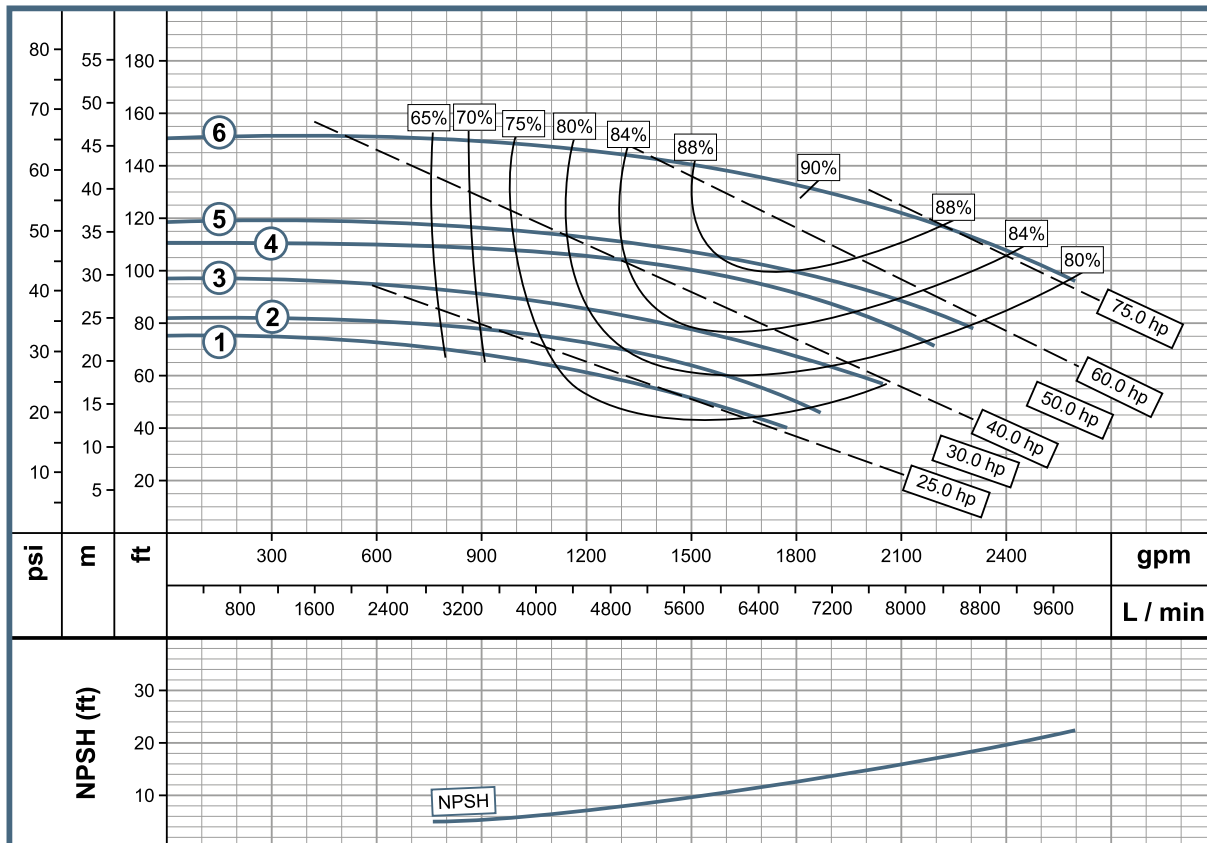

*Mechanical Seal 1 3/4" T21 for MODEL GU GE 2

TEFC Enclosure as standard configuration.

SS= Stainless Steel.

Technical specifications are subject to change without prior notice.

GS Line

- GE 6G 1000-4
- GE 6G 1250-4
- GE 6G 1500-4
- GE 6G 2000-4
- GU 6G 4



www.wdmpumps.com

Pump Features					
Pump Type	Design			Impeller	
End Suction	Close Coupled / Frame Mounted			Enclosed / Cast Iron / SS	
Stages	Mechanical Seal			Fluid temperature range	
1	2 1/4" T21			158° F (70° C)	
MODEL	Ref. Cast Iron Impeller	Ref. SS Impeller	Ø Suction	Ø Discharge	Ø Impeller
1 GE 6G 1000-4	1B0168	1B0168S	8" F	6" F	12.750"
2 GE 6G 1250-4	1B0169	1B0169S	8" F	6" F	13.500"
3 GE 6G 1500-4	1B0170	1B0170S	8" F	6" F	14.000"
4 GE 6G 2000-4	1B0171	1B0171S	8" F	6" F	15.000"
4 GU 6G 4	1B0154	1B0154S	8" F	6" F	15.000"

Motor Features			
Drive		Speed (rpm)	Frequency (Hz)
Electric		1800 (nominal)	60
Power (HP)	Phase	Voltage (V)	Frame
100	3	230/460	444JP
125	3	230/460	444JP
150	3	230/460	445JP
200	3	230/460	445JP
Frame Mounted			

Performance Curve

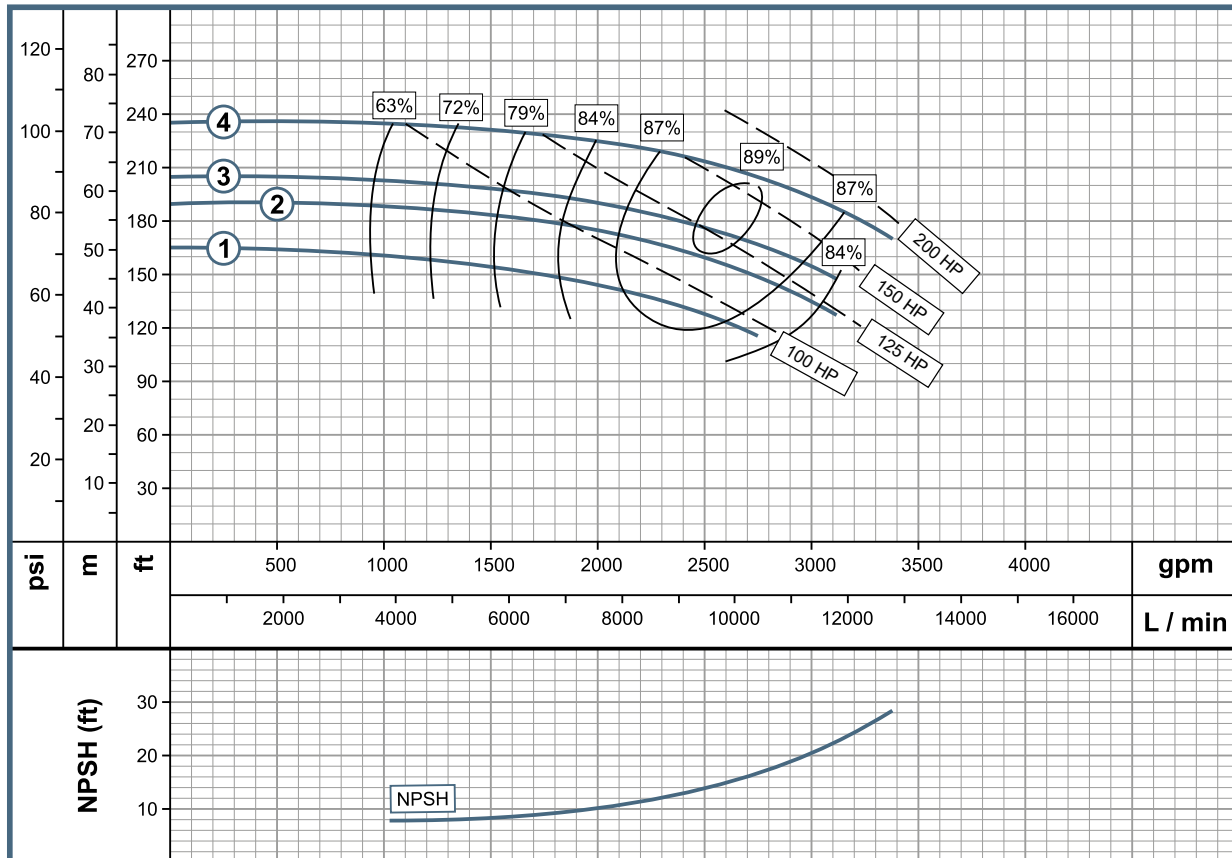

*Mechanical Seal 2 1/4" T21 for MODEL GU 6G 4

TEFC Enclosure as standard configuration.
SS= Stainless Steel.

Technical specifications are subject to change without prior notice.



GS Line

GE 8E 600-4
 GE 8E 750-4
 GE 8E 1000-4
 GE 8E 1250-4
 GU 8E 3

www.wdmpumps.com

Pump Features						
Pump Type	Design			Impeller		
End Suction	Close Coupled / Frame Mounted			Enclosed / Cast Iron / SS		
Stages	Mechanical Seal			Fluid temperature range		
1	1 3/4" T21 (1) / 2" T21 (2,3,4)*			158° F (70° C)		
MODEL	Ref. Cast Iron Impeller	Ref. SS Impeller	Ø Suction	Ø Discharge	Ø Impeller	
1	GE 8E 600-4	1B0094	1B0094S	10" F	8" F	9.550"
2	GE 8E 750-4	1B0095	1B0095S	10" F	8" F	10.500"
3	GE 8E 1000-4	1B0096	1B0096S	10" F	8" F	11.500"
4	GE 8E 1250-4	1B0097	1B0097S	10" F	8" F	12.120"
4	GU 8E 3	1B0131	1B0131S	10" F	8" F	12.120"

Motor Features			
Drive		Speed (rpm)	Frequency (Hz)
Electric		1800 (nominal)	60
Power (HP)	Phase	Voltage (V)	Frame
60	3	230/460	365JM
75	3	230/460	365JP
100	3	230/460	405JP
125	3	230/460	444JP
Frame Mounted			

Performance Curve

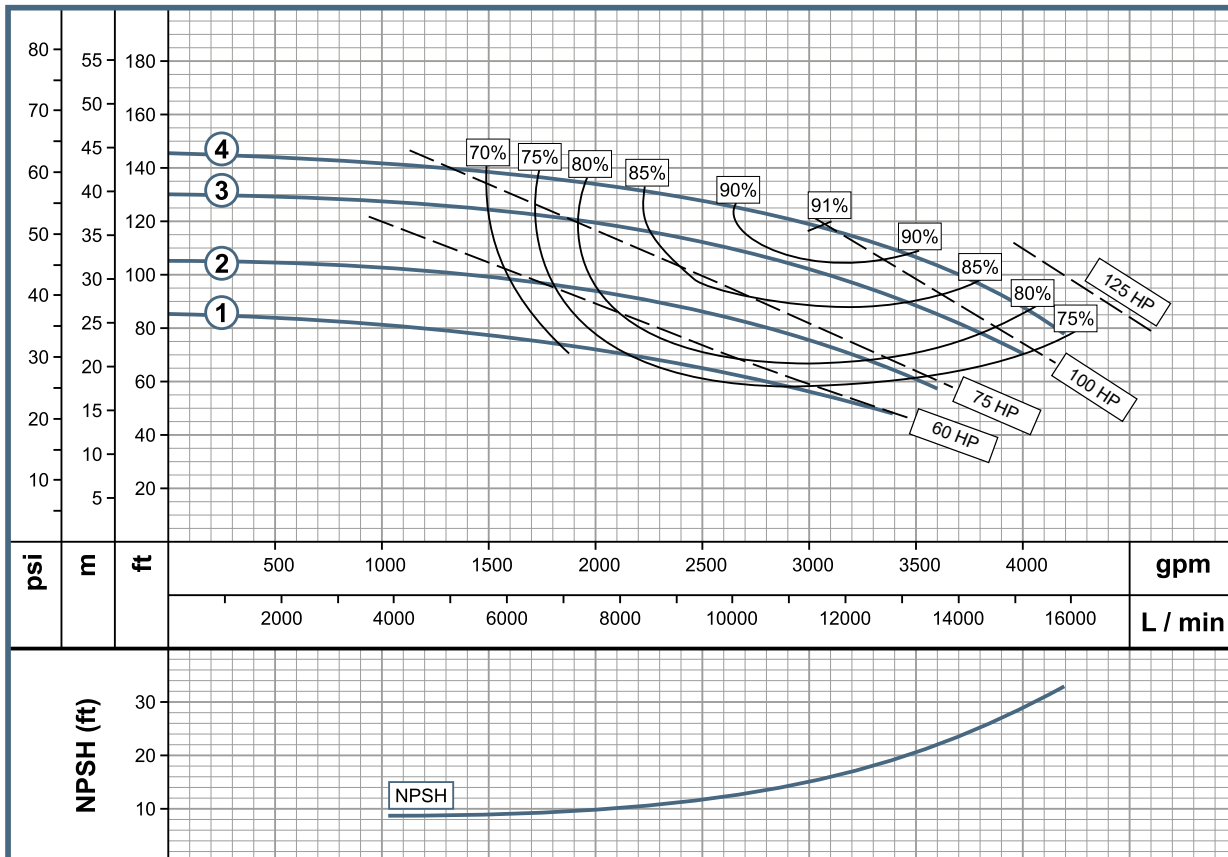

*Mechanical Seal 2 1/4" T21 for MODEL GU 8E 3.

TEFC Enclosure as standard configuration.

SS= Stainless Steel.

Technical specifications are subject to change without prior notice.



www.wdmpumps.com

Technical Book



■ www.wdmpumps.com



VERSIÓN	0
FECHA	27/06/24