

# WDM<sup>®</sup>

## PUMPS

FLOW RATES TO 15,000 GPM

HEADS TO 600 FEET TDH

CASE WORK PRESSURES TO 400 PSI

CAST IRON CASING-STD-DUCTILE IRON-OPTIONAL

STAINLESS STEEL IMPELLER

MECHANICAL SEALS

GREASE LUBRICATED BEARINGS

SINGLE AND DOUBLE VOLUTE

SIZED TO 16" DISCHARGE

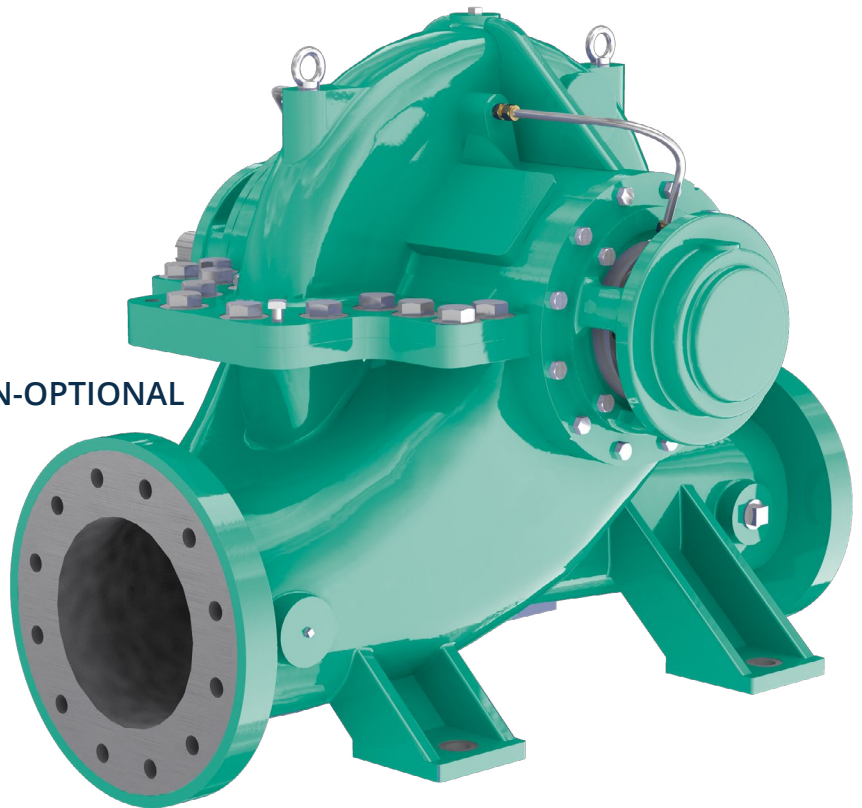

**WEAR RINGS**

Casing wear rings are standard and replaceable on all pumps. Impeller wear rings are optional.

**IMPELLER**

Double suction, dynamically balanced impellers held in place by separate nuts.

**MECHANICAL STRENGTH**

Provided with ribs and connection bosses to ensure mechanical strength during hydrostatic test and normal operation.

**BEARING HOUSING**

360° bearing housing arrangement to ensure mechanical stability and low vibration levels. Design allows to use the house for packing (as standard) or mechanical seal (optional).

**BEARINGS**

Interchangeability line and thrust bearings (rated up to 100,000 hours bearing life). Grease lubricated as standard, oil lubrication is optional.

**SHAFT**

A rigid shaft combined with double-volute casing results in low shaft deflection at all operating points. Low deflection reduces packing wear, ring wear and bearing loading, which ultimately results in sustained efficiency and economic operation.

**SHAFT SLEEVE**

Separate shaft nuts feature provides the greatest simplification of sleeve replacement. Sleeves are sealed to shaft by an O-ring to prevent leakage and subsequent erosion. 11-13% chrome sleeves are available for extended life on packing.

**CASING SEALING SYSTEM**

Innovative sealing system allows metal to metal contact (ZW model) ensuring a perfect rotor-casing alignment, improved sealing capacity and ease of maintenance

**FLANGES**

Suction and discharge connections are on the same centerline for piping ease.

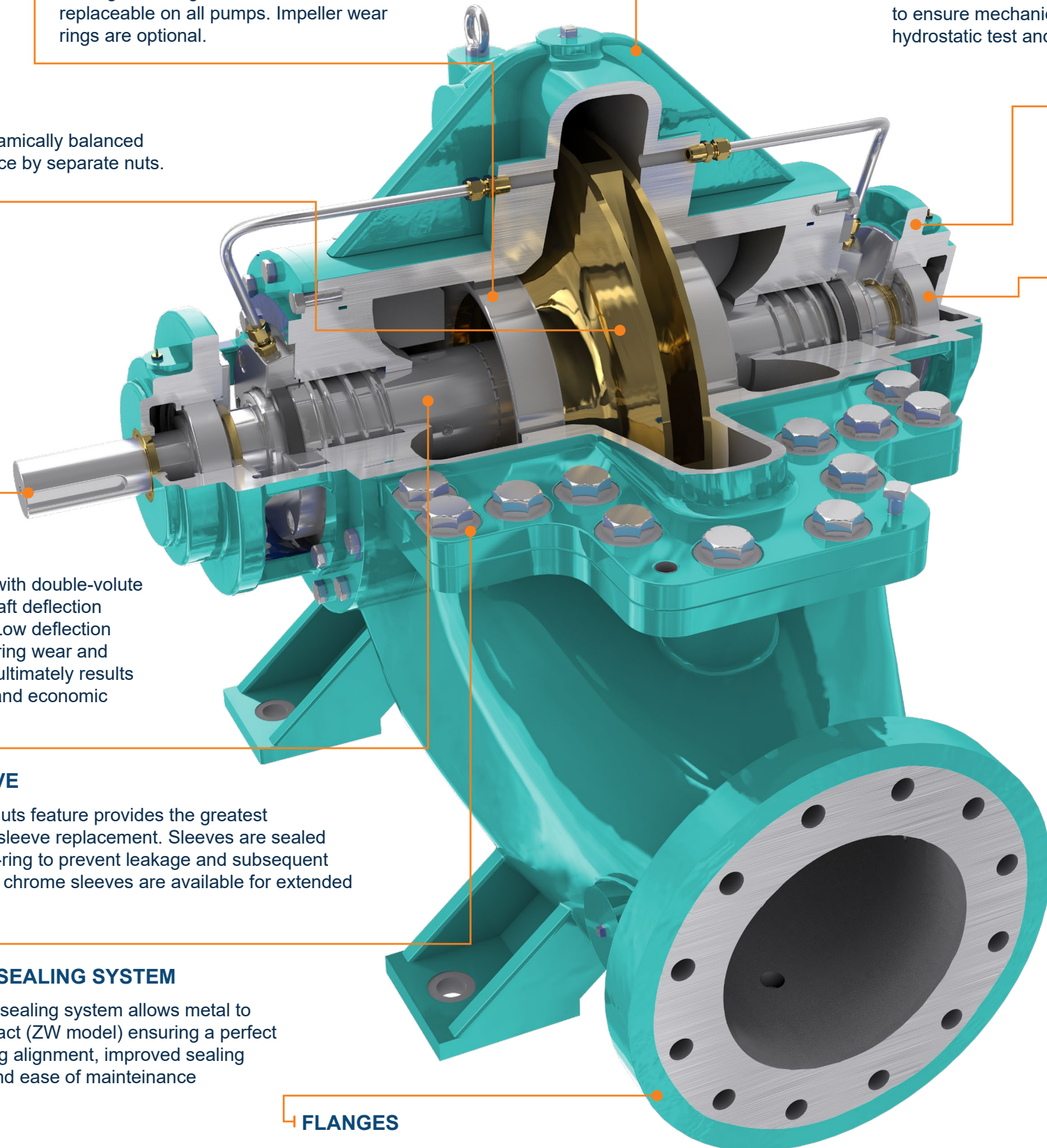

**CHARACTERISTICS AND DESIGN FEATURES**

- Hydraulic Institute (HI) design - BB1 & BB3 type.
- Horizontal, between bearings, axially split centrifugal pump.
- Single or multi-stage depending on model.
- High efficiency, foot mounted design.
- Axially split case, single-volute or double-volute (depending on model), minimizes thrust loads and allows operation over a wide range of capacities.
- Flanged connections.
- Side-side nozzle configuration.
- Double suction, enclosed impellers provide hydraulic balance eliminating axial thrust..
- Clockwise or counterclockwise rotation.
- Stuffing box allows mechanical seal option.
- Horizontal mounting arrangements available.
- Cast iron as standard material (other materials on request).

**APPLICATIONS**

For pumping of pure, raw and wastewater, as well as seawater:

- |                           |                               |
|---------------------------|-------------------------------|
| ■ Municipal water systems | ■ Irrigation                  |
| ■ Cooling towers          | ■ Desalination                |
| ■ Circulating water       | ■ Marine services             |
| ■ Raw water transfer      | ■ Cargo loading and unloading |
| ■ High and low water lift | ■ Fire protection             |
| ■ Water pipelines         |                               |
| ■ Dewatering              |                               |

*Images for general arrangement use only, not certified for construction.*

## FOREWORD

The ZW pumps are horizontally mounted axially split case, single stage, single or double cast volute, double suction centrifugal pumps. They are designed for continuous duty, with a combination of mechanical, metallurgical and installation features for applications in water.

## DESIGN FEATURES

### Casing

The ZW casing is horizontally split, with the upper and lower halves bolted and dowelled to provide perfect alignment. The upper half casing can be removed for inspection of the complete rotating assembly. Flanged suction and discharge connections are located in the lower-half casing, allowing maintenance without disturbing piping or drive alignment.

### Impeller and Wear Rings

Impellers are enclosed, double-suction type, cast in one piece and balanced to minimize vibration and thrust loads and to ensure longer bearing life. They are keyed to shaft and locked in position by wear resistant shaft sleeves and threaded locknuts. All impellers are dynamically balanced with shaft and sleeves for vibration-free operation. Impeller wear rings are optional and case wear rings are standard. \*Wear rings optionals.

### Bearing Housing

The ZW series utilizes a deep groove axial thrust bearing and a deep groove radial bearing or a radial bearing to positively control all axial and radial loads while insuring the ease of maintenance.

### Shaft

The high strength steel shaft provides maximum strength with minimum shaft deflection, ensuring maximum reliability. A rigid shaft combined with double volute-casing results in low shaft deflection at all operating points. Low deflection reduces packing wear, ring wear and bearing loading, which ultimately results in sustained efficiency and economic operation. Sleeves are sealed to shaft by an "O" ring to prevent leakage and subsequent erosion. Stainless steel sleeves are Standard. Sleeves are available for extended shaft life on packing

### Pump Seal

The ZW pump uses mechanical seal as standard and packing seal as optional.

Mechanical seal is single type (Type 1), single spring, with rotary face made of carbon graphite and stationary seat of ceramic, oriented with the pump's rotation.

The ZW pump does not use mechanical cartridge seal.

### Rotation

Clockwise rotation is available to allow flexibility of installation.

**Pump Nameplate:** Each ZW Series pump is provided with a stainless steel nameplate attached to the pump casing.

WDM® PUMPS		ZW SERIES-HORIZONTAL SPLIT CASE			
SERIES	ZW	MODEL	6X4X8F	SUCTION	6"
GPM	800	FT-HD	60	DISCHARGE	4"
RPM	1780	MAX WORK PRESS.	175 PSI		
SERIEL NO.	<input type="text"/>				

**Series:** Describes the type of pump product. In this case the "ZW" is the horizontal split case single stage design.

**Model:** Is the model number that describes the product within the Series. In this case the model number is: 6X4X8F. "6" describes the suction size in inches, "4" describes the discharge size in inches and "8" describes the maximum impeller diameter for this model.

**GPM:** Is the "Gallons per Minute" rating for this pump at its specified FT-HD requirement.

**FT-HD:** Is the specified discharge head in feet required for the pump.

**Suction:** is the suction flange size in inches.

**Discharge:** Is the discharge flange size in inches.

**RPM:** Is the motor (or driver) speed in rotations per minute.

**MAX WORK PRESS:** Is the maximum case working pressure for the pump model as ordered.

**SERIEL NUMBER:** Is the recorded description specific to this actual model of pump.

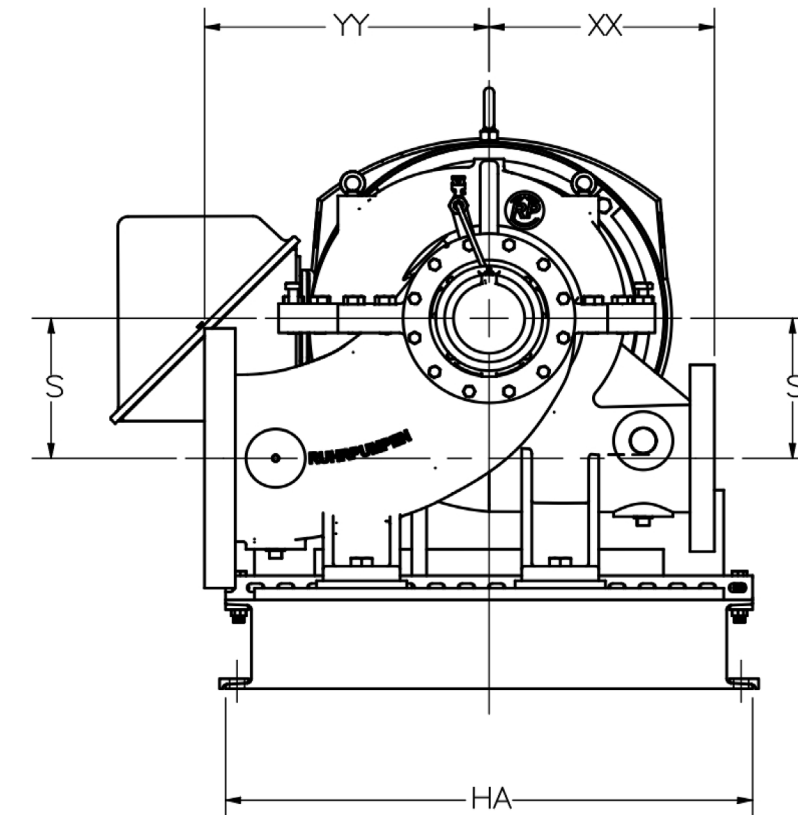
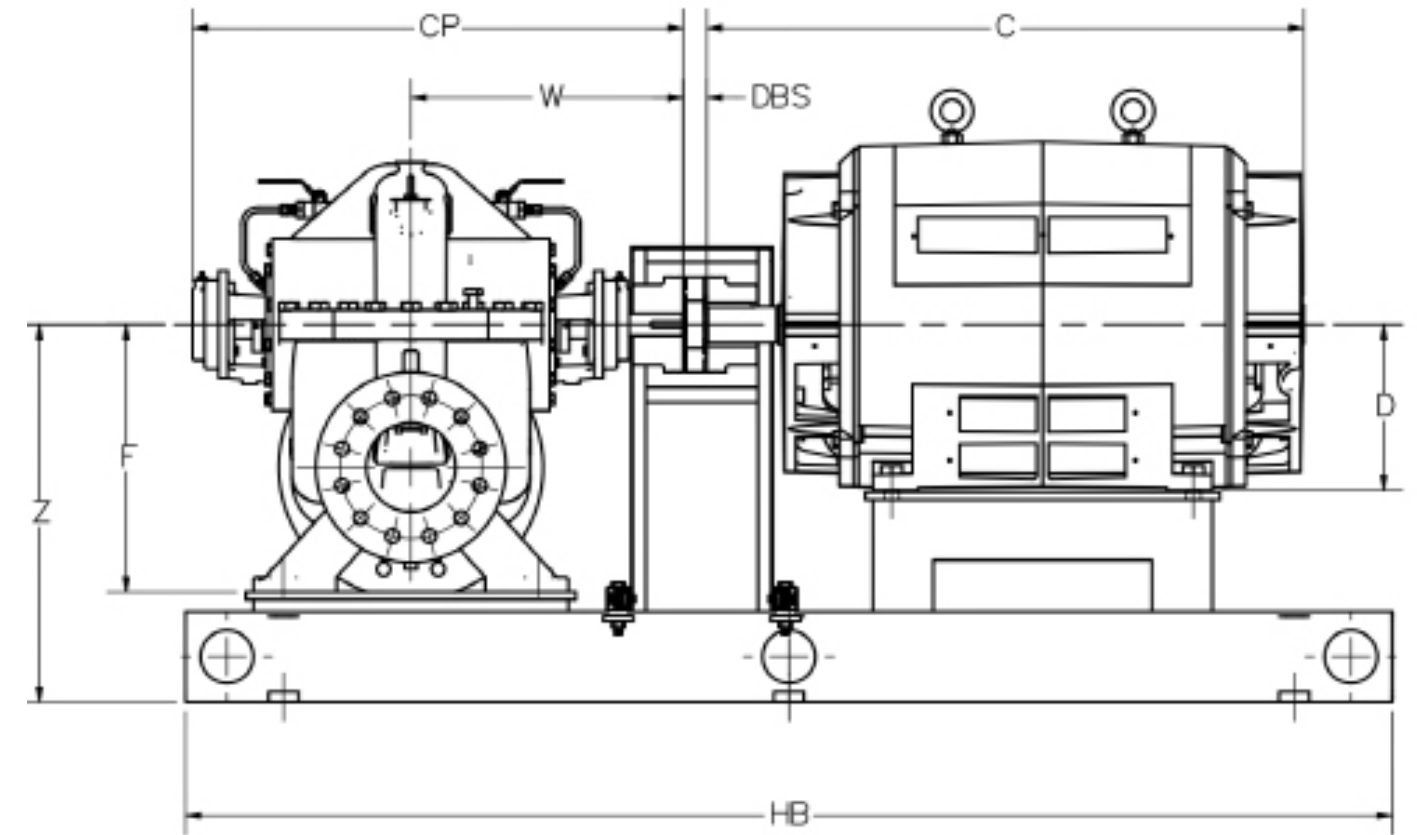

\*Only clockwise.

Pump		SUC	DIS	XX	YY	S	F	W	CP	
SIZE	SERIES	SHAFT	IN	IN	IN	IN	IN	IN	IN	
5X4X10 F	50	1	5	4	11.417	13.386	6.299	11.811	14.606	25.945
6X4X8 F	50	1	6	4	9.449	12.205	5.512	11.417	14.606	25.945
6X4X10 F	50	1	6	4	11.417	13.386	6.299	11.811	14.606	25.945
6X4X12 F	50	1	6	4	12.598	14.567	7.480	12.992	14.606	25.945
6X4X14 F	50	1	6	4	12.992	14.961	8.268	12.992	14.606	25.945
8X6X13 A	50	2	8	6	14.567	16.535	8.268	15.157	15.984	28.701
8X6X15 A	50	2	8	6	15.748	17.717	9.843	15.157	15.984	28.701
10X8X13 A	50	2	10	8	14.961	17.717	8.661	15.748	15.984	28.701
6X4X16 F	60	3	6	4	14.567	16.535	9.449	15.945	16.535	29.528
6X5X10 A	60	3	6	5	15.748	17.717	6.890	12.992	16.535	29.528
6X5X10 F	60	3	6	5	15.748	17.717	6.890	12.992	16.535	29.528
6X5X12 A	60	3	6	5	13.386	15.354	7.874	12.992	16.535	29.528
6X5X12 F	60	3	6	5	13.386	15.354	7.874	12.992	16.535	29.528
6X5X14 F	60	3	6	5	13.386	15.354	8.661	14.961	16.535	29.528
8X5X8 F	60	3	8	5	10.236	14.173	6.299	13.583	16.535	29.528
8X5X10F	60	3	8	5	11.811	14.567	7.087	13.583	16.535	29.528
8X5X12 A	60	3	8	5	13.386	15.354	7.874	14.567	16.535	29.528
8X5X12F	60	3	8	5	13.386	15.354	7.874	14.567	16.535	29.528
8X5X14 F	60	3	8	5	14.961	16.929	9.055	15.748	16.535	29.528
8X6X8 F	60	3	8	6	11.024	14.961	7.087	13.780	16.535	29.528
8X6X10F	60	4	8	6	12.598	16.535	7.874	15.748	18.031	32.520
8X6X12 F	60	4	8	6	14.173	16.929	8.268	16.535	18.031	32.520
8X6X14 F	60	4	8	6	15.748	17.717	9.055	15.748	18.031	32.520
10X6X12 F	60	4	10	6	14.567	17.323	8.661	17.717	18.031	32.520
10X6X14 F	60	4	10	6	14.961	18.898	9.449	17.717	18.031	32.520
10X8X10 F	60	4	10	8	13.386	17.717	8.268	17.717	18.031	32.520
10X8X16 A	60	4	10	8	17.717	19.685	10.236	18.898	18.031	32.520
12X8X13 A	60	4	12	8	15.748	19.685	9.843	18.898	18.031	32.520
12X10X13 A	70	5	12	10	17.323	22.441	11.024	20.472	20.551	36.969
12X10X16 A	70	5	12	10	18.898	22.441	11.024	19.685	20.551	36.969
14X10X16 A	80	6	14	10	19.685	23.622	12.205	21.654	24.882	44.606
14X10X16 F	80	6	14	10	19.685	23.622	12.205	21.654	24.882	44.606
14X12X14 A	80	6	14	12	18.898	24.409	12.205	21.654	24.882	44.606
16X12X17 A	100	7	16	12	21.654	27.559	13.780	24.016	26.339	47.283
16X12X17 F	100	7	16	12	21.654	27.559	13.780	24.016	26.339	47.283

PUMP	DBS	C	D	HB	HA	Z
SIZE	IN	IN	IN	IN	IN	IN
5X4X10 F	0.25	20	5.25	50	30	25
6X4X8 F	0.25	20	5.25	50	30	25
6X4X10 F	0.25	25	6.25	60	30	25
6X4X12 F	0.25	28	7	60	30	25
6X4X14 F	0.25	30	8	60	30	25
8X6X13 A	0.25	32.5	9	70	35	25
8X6X15 A	0.25	42	11	80	35	25
10X8X13 A	0.25	37	10	70	35	25
6X4X16 F	0.25	32.5	9	70	35	25
6X5X10 A	0.25	25	6.25	60	35	25
6X5X10 F	0.25	28	7	60	35	25
6X5X12 A	0.25	30	8	60	35	25
6X5X12 F	0.25	30	8	60	35	25
6X5X14 F	0.25	32.5	9	70	35	25
8X5X8 F	0.25	25	6.25	60	35	25
8X5X10F	0.25	28	7	60	35	25
8X5X12 A	0.25	30	8	70	35	25
8X5X12F	0.25	30	8	70	35	25
8X5X14 F	0.25	32.5	9	70	35	25
8X6X8 F	0.25	25	6.25	60	35	25
8X6X10F	0.25	30	8	70	40	30
8X6X12 F	0.25	32.5	9	70	40	30
8X6X14 F	0.25	37	10	70	40	30
10X6X12 F	0.25	37	10	70	40	30
10X6X14 F	0.25	42	11	80	40	30
10X8X10 F	0.25	30	8	70	40	30
10X8X16 A	0.25	55	12.5	90	40	30
12X8X13 A	0.25	42	11	80	40	30
12X10X13 A	0.25	42	11	80	45	30
12X10X16 A	0.25	53	11	90	45	30
14X10X16 A	0.25	58	11	110	55	35
14X10X16 F	0.25	53	11	100	55	35
14X12X14 A	0.25	55	12.5	100	55	35
16X12X17 A	0.25	60	11	110	55	40
16X12X17 F	0.25	60	11	110	55	40

CASE WORKING PRESSURES

ZW Horizontal Split Case offering is available in 3 standard construction designs. High rise HVAC applications with high suction pressures should be reviewed and documented prior to replacement or new installation. In higher working pressure environments, ductile iron fitted pumps may be more appropriate. Refer to factory for inlet pressure in excess of 250 PSI for guidance.

Table Number 1: Pump Construction Working Pressure: 1800 RPM-Max Temp 150 -degree F

DESCRIPTION	125 LB. WORKING PRESSURE	250 LB WORKING PRESSURE	300 LB. WORKING PRESSURE
Design Type	A	B	C
Casing	Cast Iron	Cast Iron	Ductile Iron
Mechanical Seal	Type 1	Type 1	Type 1 B
Seal Seat	Ceramic	Tugnsten Carbide	Ceramic
Flanges	Flat Face	Flat Face	Raised Face
Impeller	Stainless Steel	Stainless Steel	Stainless Steel
Shaft Sleeves	Stainless Steel	Stainless Steel	Stainless Steel
Shaft	Steel	Steel	Steel
Hydrostatic Test	175 PSI	350 PSI	400 PSI
Bearings	Grease Type	Grease Type	Grease Type

Table Number 2: High Rise HVAC Applications- Recommended Pump Design Type Guidelines

APPLICATION	PUMP LO-CATED	BUILDING HEIGHT TO BASEMENT LEVEL	SUCTION INLET PRESSURE (APPROX)	PUMP DIFF PRESSURE (APPROX)	TOTAL PSI (APPROX)	DESIGN TYPE (TABLE 1)
Condenser/ Chilled Water	Basement	0-75 Feet	0-75 PSI	0-50 PSI	125 PSI	A
Condenser/ Chilled Water	Basement	176-400 Feet	51-175 PSI	51-70 PSI	245 PSI	B
Condenser/ Chilled Water	Basement	176-600 Feet	176-260 PSI	71-100 PSI	360 PSI	C
Condenser/ Chilled Water	Basement	600-900 Feet	261-890 PSI	101- 125 PSI	515 PSI	STEEL-RTF

Note 1: Review inlet (suction) pressure to the pump with inlet valve fully closed (static head) and record. All valves fully open and pump operating, record suction and discharge pressure (dynamic). Provide this information at time of order entry.

## Advanced pumping technology that moves our world

The outcome of many years of experience in the design and manufacture of centrifugal pumps, the WDM ZW pumps are single- or multi-stage, single or double volute, axially split case centrifugal pumps.

The ZW pump is designed and built according to the Hydraulic Institute (HI) standard (BB1 & BB3 types). Depending on mechanical features and material selection, it can pump various fluids providing maximum reliability in general industry applications, power generation plants, municipal water systems, mining operations, fire protection and many other industries. *For API build, check the ZM pump range.*

### High reliability

These pumps are engineered for continuous, heavy-duty pumping with several combinations of metallurgical, mechanical and installation features to fit any specific needs.

### Flexible design

To minimize footprint and simplify installation, all our ZW pumps can be mounted in horizontal or vertical arrangements, according to customer requirements.

### Easy-maintenance design

The axially split casing allows for the upper half to be removed for inspection and maintenance of the complete rotating assembly without disturbing piping or drive alignment.

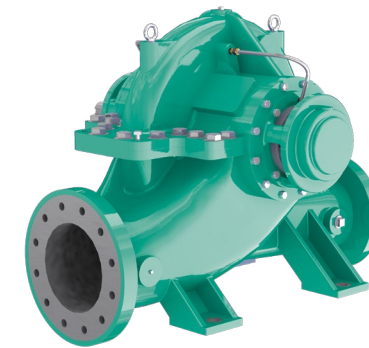

ZW

***Our complete range of Horizontal Split Case Pumps and our expertise in pump engineering, allows WDM to bring a solution to every customer.***

MODEL	STAGES	VOLUTE	IMPELLER	CAPACITY	HEAD
ZW	Single	Single and double volute	Double suction, enclosed impeller	up to 40,000 gpm up to 9,000 m <sup>3</sup> /h	up to 1,115 ft up to 340 m



**MEXICO:**

Monterrey

Address: Sigma 9224 Cd. Industrial Mitras, García,  
N.L., PC: 66000.

Phone: (81) 8381 0913

Guadalajara

Address: Calle Javier Ruiz Velazco No.10, Colonia  
Balcones del Sol, Zapopán, Jalisco. CP 45068.

Phone: (33) 3812 9481

Hermosillo

Address: Av. Primera de Periférico No. 436, entre  
Simón Bley y Manuel I. Loaiza, Colonia Luis Encinas.  
PC 83138.

Phone: (66) 2207 1158

Estado de Mexico

Address: Boulevard Centro Industrial No. 26 Bod, B2  
Fraccionamiento Industrial Puente de Vigas,  
Tlanepantla. PC 54070

Phone: (55) 5384 1691

Cuernavaca

Phone: (777) 500 5435

Puebla

Phone: (81)1660 7495

Cancún

Phone: (81)2621 3761

Mexicali

Phone: (664) 484 0497

Chihuahua

Phone: (614) 231 8070

Villahermosa

Phone: (993) 128 9458

**PANAMA:**

Ciudad de Panamá

Address: Calle W con calle 15, Parque Lafevre.

Phone: (+507) 221 1171

**COLOMBIA:**

**Bogota D.C.**

Address: Aut. Bogotá - Medellín KM 7,5 Costado  
Occidental, Parque Industrial Celta Bod. 86 y 93.

E-mail: [construccion@barnes.com.co](mailto:construccion@barnes.com.co)

PBX: (+1) 743 9090

Fax: (+1) 742 6825

**PERÚ:**

Lima

E-mail: [edcasado@wdmpumps.com](mailto:edcasado@wdmpumps.com)

Phone: (+511) 9878 15371

**ARGENTINA:**

Provincia de Buenos Aires

Address: Le Corbusier 240 (B1616AEF)

Phone: (+5411) 4463 1477 / (+5411) 4463 3000

**UNITED STATES:**

Tulsa, Oklahoma

Address: 4501 S 86th East Ave, OK 74145

Phone: 800 783 6756 / 214 337 8780

**GUATEMALA:**

Ciudad de Guatemala

Address: 2a. Ave. 13-35, Zona 17 Ofibodega N. 16,  
Los Almendros

Phone: (+502) 2255 1796 / (+502) 2255 5937