



Bombas IS Industrial Service

HIERRO

Acople universal

IU 100X080X160

Características de la bomba

Tipo de bomba	Acoplamiento	Tipo de impulsor	Temperatura máx. líquido	Sello Mecánico	Velocidad (rpm)		
Centrifuga	Universal	Cerrado Balancado ISO (G 6.3)	90 °	1 1/4" Tipo 12	3600 rpm		
Modelo	Ref.	Ø Succión	Ø Descarga	H máx. (mca) *	Q máx. (gpm) **	Etapas	Peso Kg
IU 100x080x160	1K0419	100 mm	80 mm	56	1013	1	48,1

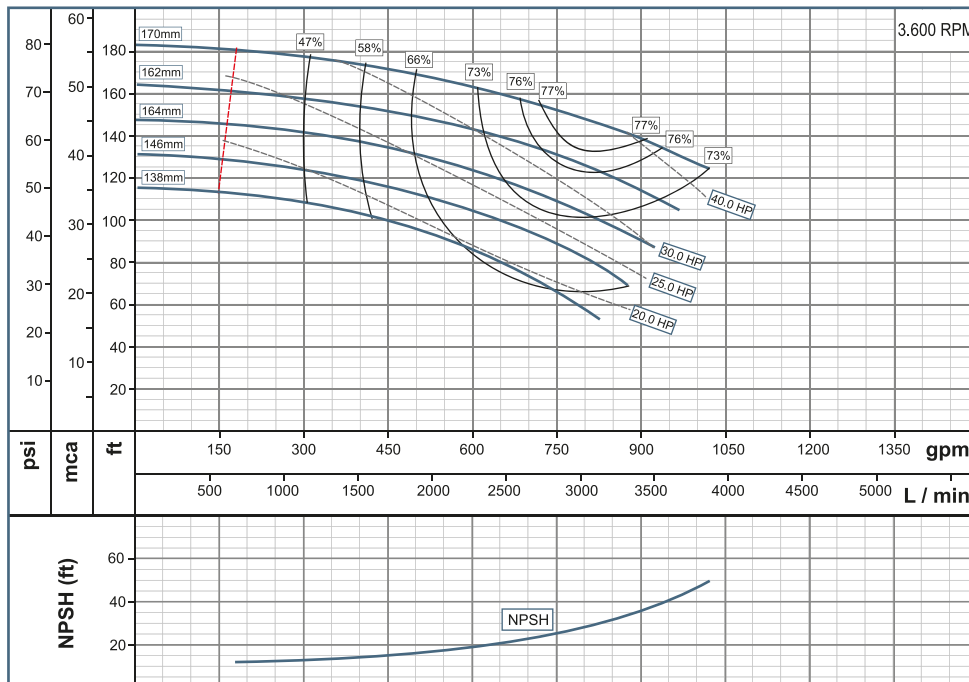

Aplicaciones

- * Suministro de Agua
- * Riego
- * Drenaje
- * Sistema de calentamiento
- * Sistema de Aire Condicionado
- * Servicio de agua
- * Agua Caliente

FLANGE		PUMP DIMENSIONS				SUPPORT DIMENSIONS					HOLES FOR		FLANGE DN1			FLANGE DN2			SHAFT END			
DN1	DN2	A	F	H1	H2	M1	M2	N1	N2	N3	W	S1	S2	Z	No	DIAM	Z	No	DIAM	U	X	Y
100	80	125	360	180	225	125	95	320	250	110	249,5	14	13	180	8	18	160	8	18	24	8	27

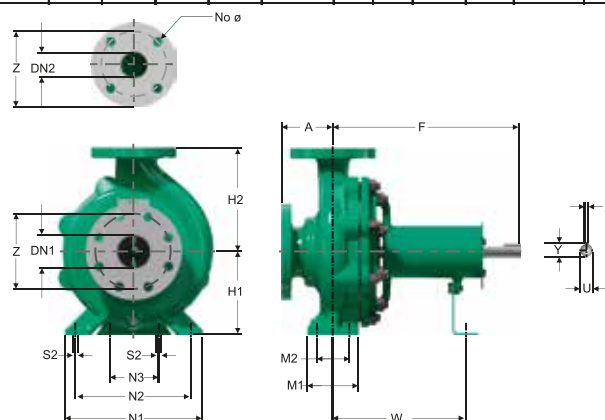

Dimensiones en milímetros

Fecha última revisión

2017-5-2