

Bombas IS Industrial Service

HIERRO

Acople Universal

IU 080x065x200

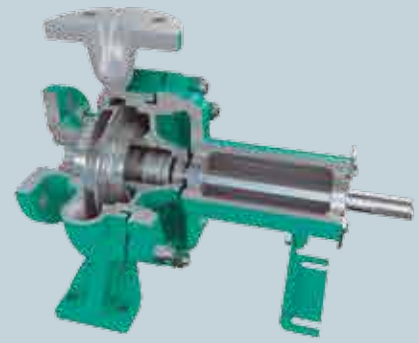

Características de la bomba

Tipo de bomba	Acoplamiento	Tipo de impulsor	Temperatura máx. líquido	Sello Mecánico	Velocidad (rpm)		
Centrífuga	Universal	Cerrado Balancado ISO (G.6.3)	90 °	1 3/4" Tipo 21	3600 rpm		
Modelo	Ref.	Ø Succión	Ø Descarga	H máx. (mca) *	Q máx. (gpm) **	Etapas	Peso Kg
IU 080x065x200	1K0416	80 mm	65 mm	91	643	1	51,6

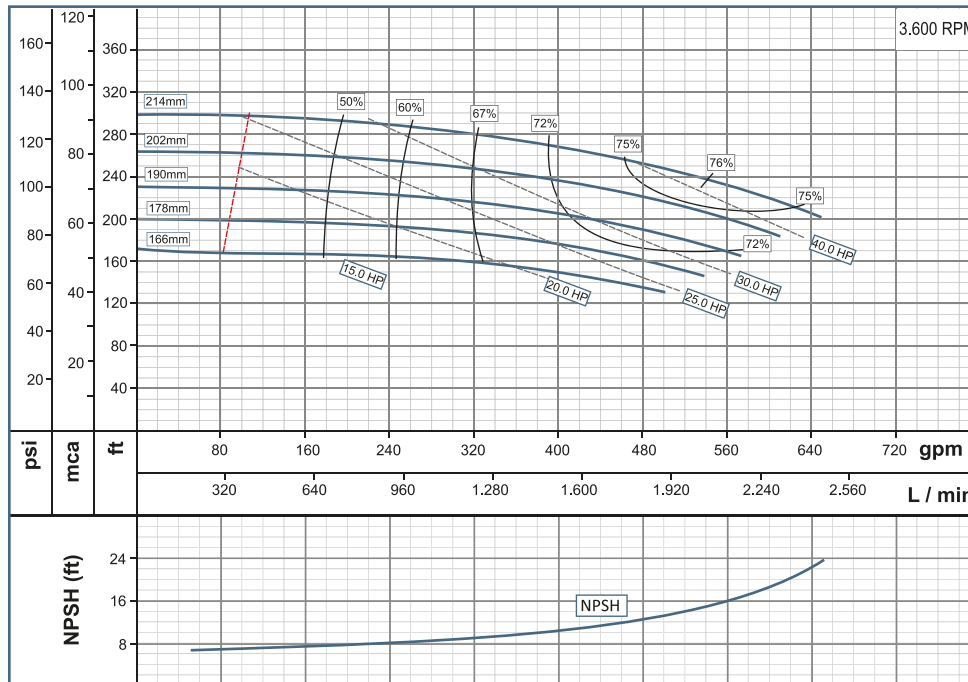

Aplicaciones

- * Suministro de Agua
- * Riego
- * Drenaje
- * Sistema de calentamiento
- * Sistema de Aire Condicionado
- * Servicio de agua
- * Agua Caliente

FLANGE		PUMP DIMENSIONS					SUPPORT DIMENSIONS					HOLES FOR		FLANGE DN1		FLANGE DN2			SHAFT END			
DN1	DN2	A	F	H1	H2	M1	M2	N1	N2	N3	W	S1	S2	Z	No	DIAM	Z	No	DIAM	U	X	Y
80	65	100	360	180	225	125	95	320	250	110	249,5	14	14	160	8	18	145	8	18	24	8	27

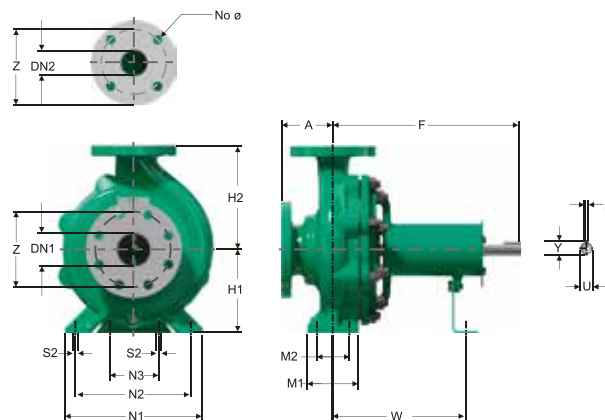

Dimensiones en milímetros

Fecha última revisión

2017-5-2